



# The Catalog





# Contents

## Company

Starting on Page 4

Major added value	4
A brief portrait of C+P	8
Industrial solutions and planning support	10
Sustainability: Made of steel—naturally	12
Innovations and awards	14
The C+P logistics concept	16
Corrosion protection and quality assurance	22
Our references	24
Trend products	36

## Color concept

Starting on Page 44

Color moods and effects	46
The new C+P color concept	48
C+P decor fronts	50
C+P office furniture decors	52

## Changing room & wardrobe

Starting on Page 54

### Changing room and wardrobe

Classic PLUS lockers	60
Evolvo PLUS lockers	98
Locking systems	158
Cambio lockers	166
Prefino/Flex PLUS lockers	186
School and assembled box lockers	192
Locking system info pages Examples of many different options	214
Stackable benches and benches with a coat rack, BASIC and COMFORT	220
Wall-mounted and free-standing wardrobes, open wardrobes and assembled box lockers	232
Industry-specific and custom solutions	242

## Workshop & factory

Starting on Page 258

### Cabinets, workbenches and shelving

Hinged-door cabinets	262
Sliding-door cabinets	312
Workbenches, drawer cabinets, mobile cabinets & stations and perforated plates	326
Shelf systems	340

## Office & archive

Starting on Page 352

### Cabinet and filing systems

Hinged-door cabinets	356
Sliding-door cabinets	386
Tambour cabinets	400
Drawer and filing cabinets	414

### Office furniture & accessories

Counters and lounge furniture	440
Tables	446
Around the desk	454
Chairs and stools	460
Cabinets, pedestals and caddies	470
Order number and weight register	482
Index	496

# What kind of added value does C + P offer to retailers?



## Catalog

The new catalog provides retailers with a digital tool. Prices are updated automatically from a database, ensuring that the contents are up to date. The chapters can be flexibly compiled using our catalog configuration tool based on the customer's wishes and the respective subject area. The digital version itself can also be generated with branding (logo and project name) free of charge. Internal links guide the user through the world of C + P products.



## Website

Our new website offers retailers quick and easy processing. This makes custom price inquiries possible and rebate information available via retailer login. Orders are entered digitally and processed automatically.

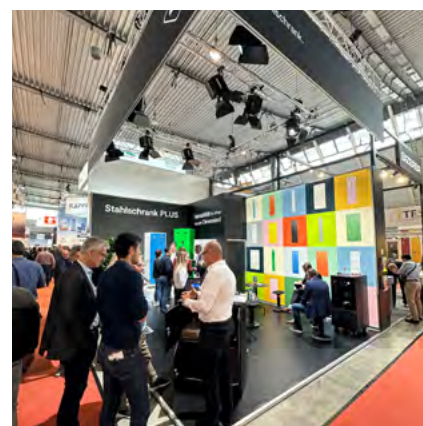

## Trade shows

C + P exhibits at a large number of trade shows. We also offer retailers roll-ups and advertising materials for ideal sales support. We'd also be happy to provide support through our sales team.



## Brochures

In addition to our catalog, we also provide our customers with product-specific brochures. This allows us to cater to target groups and applications in particular, so as to present our products in a more detailed way.



## Sales team

Our sales team provides support for project inquiries, product listings and customer catalog designs both digitally and on site. C + P is also represented internationally by competent contact partners.



**Follow us on social media:**  
C + P Möbelsysteme GmbH & Co. KG  
cp\_derstahlschrank





Heinze is Germany's leading portal for building products, company profiles and architectural projects.

C + P Möbelsysteme is represented with tender specifications on all products here. Printed documentation can also be ordered directly through Heinze by logging in.



Oxomi is a platform for marketing and product information. It connects associations, retailers and industry.

C + P Möbelsysteme is a member of OXOMI. Retailers can download our current documentation, such as price lists, the catalog and guidelines, at this portal.

## BMEcat

BMEcat is a standardized exchange format for electronic product catalogs and multimedia catalog data between suppliers and customers. "BME" stands for the "Bundesverband Materialwirtschaft, Einkauf und Logistik e. V." (German Federal Association of Materials Management, Purchasing and Logistics), one of the initiators.

A comprehensive selection from the C + P range can be provided for further use electronically. For this purpose, we can make the corresponding data available in the customary BMEcat format or, if desired, as a CSV file.

The benefits to you:

- + Save time/money through data transfer
- + Comprehensive item information in a file, incl. the associated image data for download
- + The probability of error is reduced both here and during the subsequent ordering process.
- + Up-to-date product prices and data, which improves master data quality

### Our image database is also available:

Following a brief registration, you'll be able to download images of our products in all common colors from our image database. These are excellent-quality images which can be used by you accordingly. Three different resolutions are available here: low, medium and high.





C+P

The steel locker  
The original, since 1925.



About C+P →



# Why choose the number-one locker?



**Suitable solutions  
for every industry**



**Responsibility for people  
and the environment**



**Long service life  
through tradition**

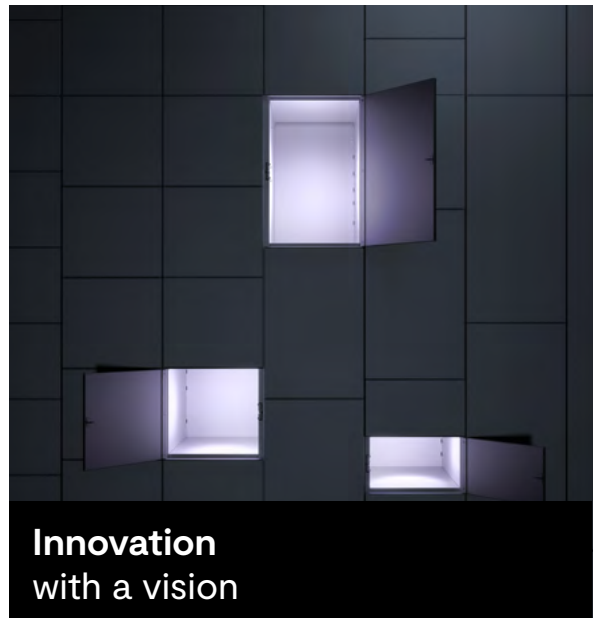

**Innovation  
with a vision**

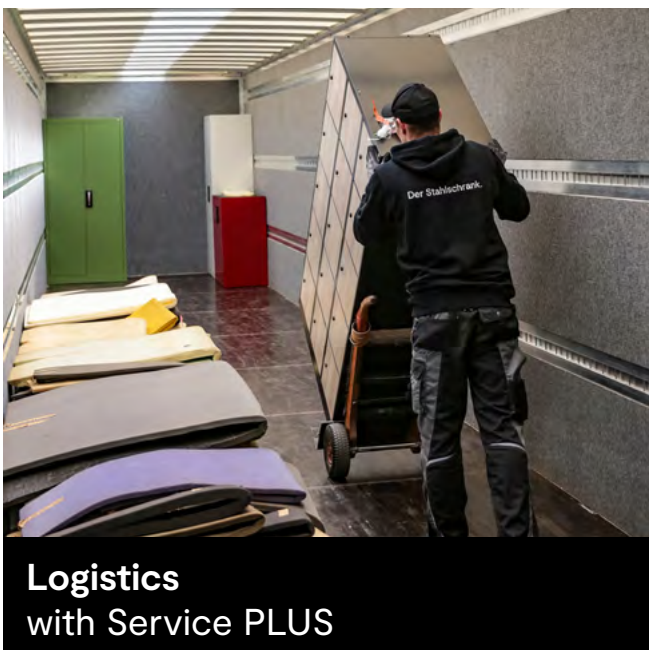

**Logistics  
with Service PLUS**



**Designs  
with distinction**



# C+P

## A brief portrait.

The Christmann + Pfeifer (C+P) company was founded in Breidenbach in the state of Hesse in Germany in 1925, making it nearly 100 years old. In addition to the company headquarters, production locations of C+P currently include factories in Gotha, Thuringia and Legnica, Poland. We've compiled key facts and figures on the company in a brief overview for you here:



## C+P by the numbers:

<b>Founded in</b>	1925
Employees at C+P Einrichten	Around 650
Production sites	Breidenbach (Hesse, Germany) Gotha (Thuringia, Germany) Legnica (Poland)
Sales	Worldwide
Production capacity	Over 100 truck loads leave C+P factories every week
Material volume	C+P plants process around 1,000 metric tons of steel every month
Orders	C+P handles over 65,000 orders per year, from individual items to entire furnishings for major projects
Claim to fame	<b>Specialist and market leader in steel furniture</b>



# Long service life through tradition!

Since its founding, C+P has developed countless product innovations together with its customers and successfully brought them to market. A lot's changed since then, but one constant has always remained the same: the level of quality which became the trademark of C+P long ago. It's reflected in the entire process chain, from material purchasing to production and painting to the delivery and installation of our products.



## Trusting is good...

...but it's better to check. As least as far as quality assurance is concerned. This is precisely why both our production processes and C+P products themselves are subjected to extremely demanding quality management based on two pillars: our company-internal test laboratory on the one hand and, of course, regular external inspections and checks on the other.

## Our certifications:



Quality management  
ISO 9001



Energy management  
ISO 50001



Environmental management  
ISO 14001



Certification →



Many of our products have been tested by TÜV Thüringen GS (Thuringia Technical Inspection Agency). We would be happy to send you copies of the relevant certificates if required.



HPQR  
certificate



EcoVadis  
certificate



# Suitable solutions for EVERY industry.

Across the globe, thousands of specialist dealers, companies and institutes trust furniture solutions from C+P—from craftsmen’s businesses to large industrial corporations. A crucial reason for this is that C+P products aren’t one-size-fits-all solutions. Instead, they’re always oriented toward the specific requirements of the industry in which they’re used. This already starts with the planning phase.



## Our expertise is your advantage!

Each and every one of our customers benefits from the nearly 100 years of experience boasted by C+P in the planning and implementation of furnishing projects in a wide variety of different economic sectors. Our sales department is familiar with the specific nature of different industries, which is why it knows exactly what it all comes down to— both when selecting custom-tailored products & suitable equipment and during the overall implementation later on.

- + Industry & trade
- + Banks & insurance
- + Police/Fire service/  
Technical Relief Agency
- + Hotels & restaurants
- + Kindergartens & schools
- + Self-employed & freelancers
- + Hospitals & clinics
- + Sports facilities & swimming pools
- + Building companies
- + Recreation & vacation complexes
- + Colleges & universities
- + Transport & logistics
- + Transportation companies
- + Retail & service
- + Public administration & authorities





# PCon

## Planning support.

Whether it's office furniture, changing rooms, workshop equipment or outdoor transfer stations: We have a solution for everything! Our project planning team creates specific plans according to your needs. In special cases, measurements are taken and details on the rooms are clarified so as to avoid obstacles and interfering factors during the furniture planning process. Virtual scanning allows the rooms to be transferred directly into a 3D model which can be provided to the project planner.

### Individuality & product configuration

Using the pCon OFML data, all C+P Möbelsysteme product groups can be individually designed and precisely planned in your floor plans by our project planners. More than 24 standard colors, 4 MDF and 8 HPL decors are available for the decor front area and 8 MCPB and 4 HPL decors for office furniture. Naturally, additional RAL and decor colors can be requested and provided. This means that furniture personalization is of paramount importance here. Configure, visualize and download your product using our website or the pCon.planner/pCon.box.

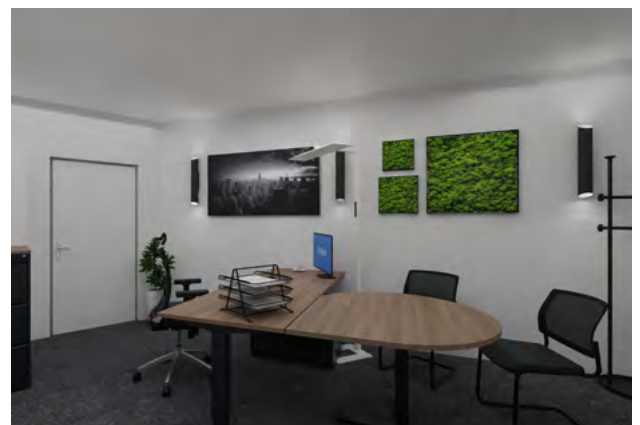
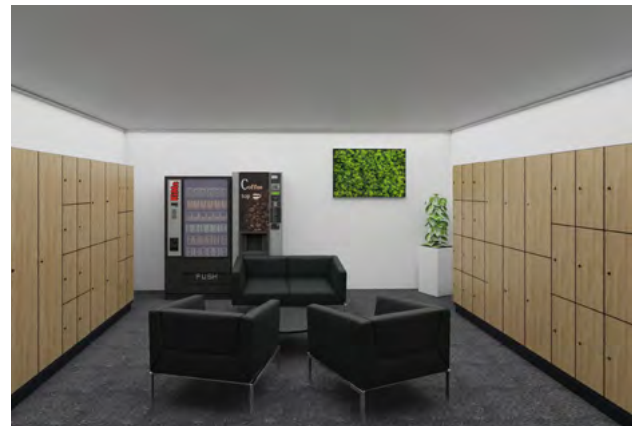

# Responsibility for people and the environment.



Social and ecological sustainability have always characterized C+P's conduct and economic activity. We also accept that we serve as an example of a market-leading company here. This being the case, we're always working on meeting this major responsibility continually and to the best of our ability in every area. Some of the ways we're making this happen:

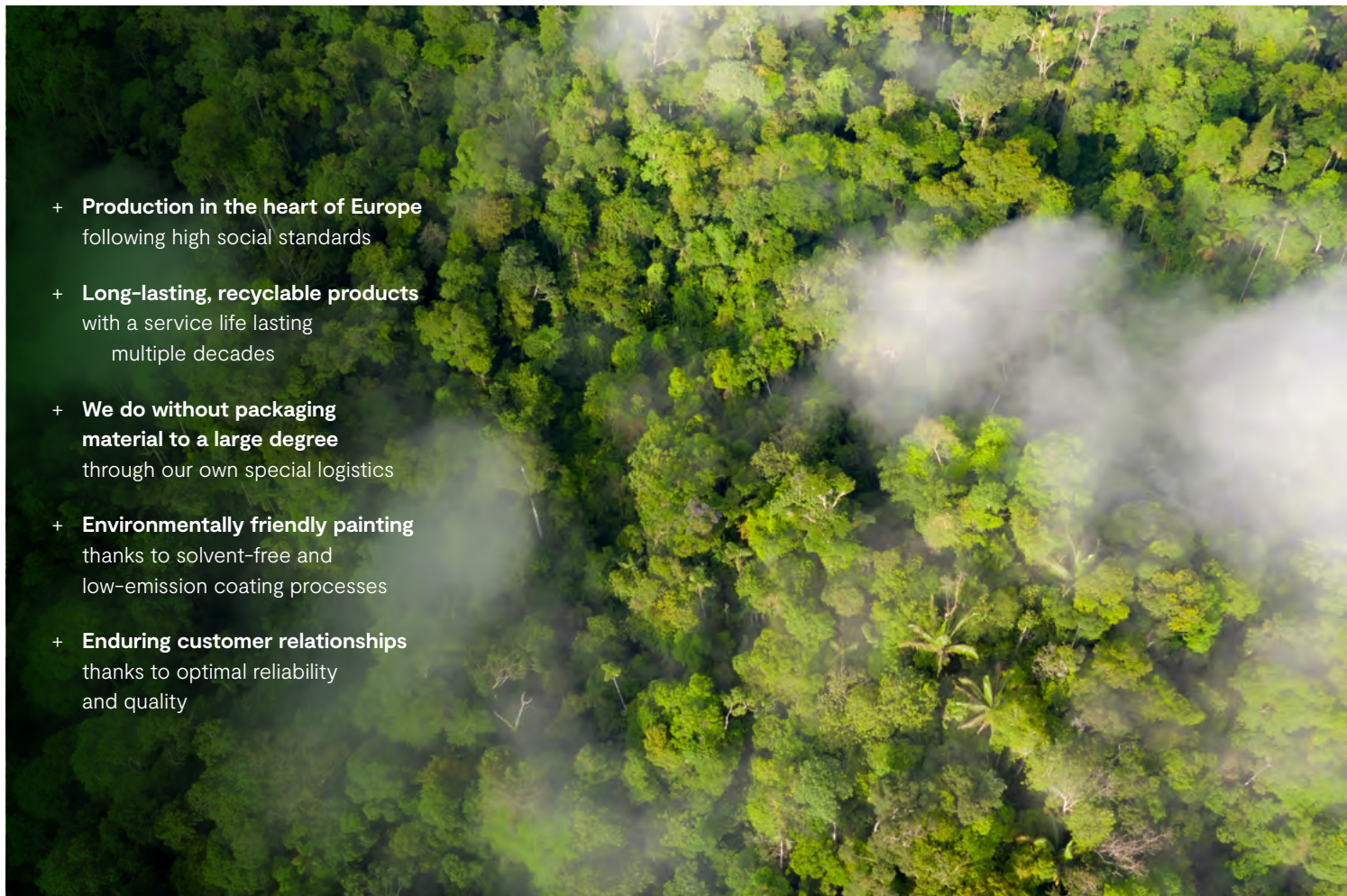

- + **Production in the heart of Europe**  
following high social standards
- + **Long-lasting, recyclable products**  
with a service life lasting  
multiple decades
- + **We do without packaging  
material to a large degree**  
through our own special logistics
- + **Environmentally friendly painting**  
thanks to solvent-free and  
low-emission coating processes
- + **Enduring customer relationships**  
thanks to optimal reliability  
and quality



## Outstanding sustainability

At the end of 2022, C+P was awarded the silver medal for sustainable economic activity by the renowned "EcoVadis" rating agency.

Quality on the highest level—from the products to the processes. C+P has been certified in the areas of

- + quality management (ISO 9001)
- + environmental management (ISO 14001) and
- + energy management (ISO 50001)

by the Deutschen Managementsystem Zertifizierungsgesellschaft mbH certification company. This ensures consistently high quality in every area and process.

This was preceded by an intensive and demanding evaluation of our conduct in the areas of "environment," "employment and human rights," "ethics" and "procurement." The internationally recognized sustainability standards of the Global Reporting Initiative, the UN Global Compact and best practice guideline ISO 26000 were applied here.





## The material of steel: A sustainable all-rounder!

Steel forms the basis of all our products. No other material boasts as many positive features when it comes to stability, design and the long-term value of storage area furnishings. Add to this the fact that steel makes an important contribution to resource conservation. The material can always be melted down again and processed for new purposes without any loss in quality. Incidentally, half of all steel in Germany is already being produced from this secondary raw material.



Warranty →



### Steel furnishings are

- + extremely sturdy and resilient
- + extremely long-lasting
- + able to be moved any number of times
- + up to 100 percent recyclable
- + available in the latest designs
- + available in any color
- + combinable with other materials
- + easy to care for and especially hygienic
- + fire protection in practice



Our high-quality steel furniture comes with a **10-year warranty!** The C + P warranty conditions can be found at [www.cp.de/en/complaint-1-1/](http://www.cp.de/en/complaint-1-1/)

# Innovation with a vision.

Innovations from the C+P brand are never gimmicky—they always pursue clear goals: making working life easier, increasing comfort and well-being, making processes more efficient and, most importantly, ensuring sustainability! This is why our developers are always thinking 1 or 2 steps ahead when carrying out their work, for example:

Less is more!

## BIONIC steel frame

For the new PLUS-series steel locker, C+P developed a design form which sets new standards in stability and resource conservation. The models of the series are reinforced in a targeted way in crucial places and feature a sophisticated internal structure consisting of folds, braces and intermediate spaces—similar to the leaves of a tree. The result is increased torsion resistance with less raw material and resource consumption.

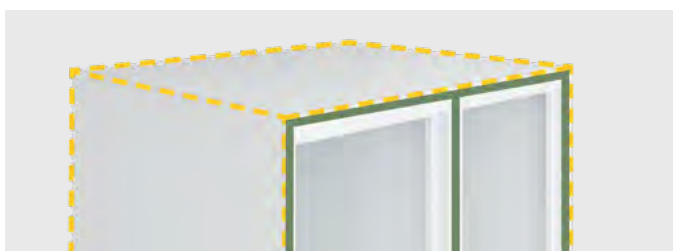

New world of working?

## SmartLocker!

With the C+P SmartLocker, we've developed storage area furnishings which—unlike conventional solutions—are no longer content being a passive place for storage. Indeed, it rises to the occasion as a true asset at its place of use. Digitally controllable and networked, suitable for just about any desired customization and exuding timeless elegance, the SmartLocker creates solutions for the requirements of the modern world of working—both today and tomorrow!





# Designs with distinction.

For decades, the classic design of our steel furniture has shaped the appearance of countless commercial spaces around the world. Thanks to their rugged elegance, several different C+P lockers became true design icons long ago. Nevertheless, C+P products remained—and still remain—in touch with the times, such as the new PLUS-series steel locker and our SmartLocker digital locker system. As an aside, the latter was distinguished with the internationally renowned German Design Award and the iF Design Award in 2023.

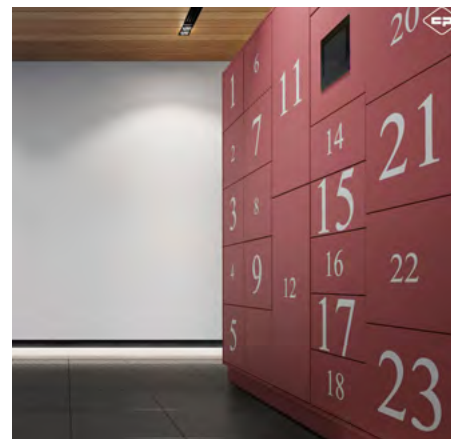



**Environmentally friendly and fair**  
The C + P loading system makes packing our furniture unnecessary, and the transport material is reused. This conserves raw materials and prevents the creation of all sorts of waste.



# Logistics with Service PLUS

Long ago, it became yet another element of advertising for our company: **C+P logistics. With 40 of our own trucks and 80 furniture trailers in all it ensures the on-time delivery of our steel furniture reliably, safely and in an environmentally friendly way.**



## Reliable and on time

C + P's in-house scheduling department plans our deliveries from a central location, in a customer-oriented way and using the fastest possible routes. Direct shipping means there's no need for any transshipment.

This saves time and avoids potential sources of delay.



## Safe and protected

Thanks to our proprietary loading system, our products are protected from any damage throughout the entire shipping process.

Our specially trained drivers and installers work extremely carefully and personally ensure flawless delivery of the furniture.



## Comprehensive service

As standard, we deliver to our customers over direct routes, on coordinated delivery dates and with no shipping charges. This also includes advance notification of the exact delivery time.

A whole host of optional additional services are also available to you—up to and including full installation of the furniture.



# Steel lockers that get there safely Quickly and reliably.

As one of the few manufacturers in our industry, C+P has its own vehicle fleet. 40 of our own trucks and 80 furniture trailers ensure delivery which has been delighting our customers for decades. Our in-house centralized scheduling department plans our order volume in a customer-oriented way.

Our own vehicle fleet is supplemented by 15 permanent partner shipping companies. All vehicles comply with the Euro 6 standard. Trailers generally feature a lifting platform for conveying the lockers to you safely.



Our in-house scheduling department handles customer requests.



[www.cp.de/en](http://www.cp.de/en) →



C+P trailer with lifting platform





The team in Breidenbach is proud of the new fleet of trucks.

## The advantages of C + P logistics

- + Just about everywhere in Germany and in many countries in Europe, we carry out delivery directly to the desired unloading point using our own fleet of trucks and without any transshipment. That's why we don't need to use any packaging material and can avoid waste.
- + Trained loaders, drivers and installers know "their" products and handle them carefully.
- + You can expect on-time and professional delivery, which saves time, money and your nerves.



# The C + P logistics concept

If you do not specify any special wishes with the order, the standard conditions of delivery will apply. We deliver FREE OF CHARGE TO THE GROUND FLOOR in Germany (behind the first lockable building door).

## General requirements

Truck deliveries generally only take place on weekdays (Monday through Friday) from around 8 a.m. to 5 p.m. For all scheduled event types, the minimum delivery time established on the day of order clarification must be taken into account.

### **Applies within the Federal Republic of Germany.**

This does not apply for islands, locations inaccessible by private transport or downtown areas and streets blocked off to truck traffic.

### **Parcel delivery**

Items which can be delivered as parcels are packaged properly and shipped at a reasonable flat rate.

### **Environmentally friendly delivery**

Shipments transported by truck are generally unpackaged.

### **Note on service packages B1 through M1**

Existing elevators, doors, passageways, ceiling heights and paths must be large enough and safe. No spiral, marble or wood staircases.

### **For truck delivery**

The unloading point must be accessible by a large semi-trailer (18 m). Ability to park in the immediate vicinity.

### **Size examples:**

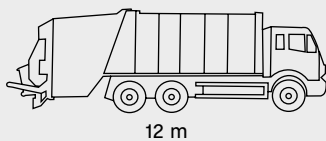

Standard conditions of delivery

Service package B1

Service package B2

Service package T1

Service package T2

Service package M1

Notification

Scheduled event types

### **Notice**

A location is considered accessible if it can be reached by a wheelchair user without the aid of anyone else.



## Service scope

### Truck delivery within Germany

DELIVERY FREE OF CHARGE TO THE GROUND FLOOR: Arrival, unloading and transport to behind the first lockable building door on the ground floor, accessible.

### B1: Accessible delivery

Free delivery to the location of use, if transport path is accessible, only for products up to 99 kg. Transport in the building on a normal path to the location of use, excluding set-up, excluding installation.

Same as B1, plus additional charge for heavy products (100 kg or more).

### T1: Free delivery to location of use with transport on stairs.

For products up to 99 kg, excluding set-up, excluding installation.

### T2: Transport on stairs

Possible with a product weight of 100 kg or more. To create your custom offer, we require a description of the transport path: [www.cp.de/twb](http://www.cp.de/twb)

### Installation services

Free delivery to the location of use, including set-up, alignment and installation at the usage site, excluding configuration of the interior fittings. To create your custom offer, we require a description of the transport path: [www.cp.de/twb](http://www.cp.de/twb)

**Notification of delivery** around 1 to 3 days prior to the planned delivery date, free of charge, via e-mail to the responsible contact person.

Scheduled event types without additional charge:

**Approx. delivery week:** Anticipated delivery time frame within one calendar week.

**Fixed delivery week:** Binding delivery during a predefined calendar week.

Scheduled event types with an additional charge:

**From-to dates:** Binding delivery within a time frame of at least 3 days.

**Specific date:** Binding delivery on a specific delivery date with a time window of 8 a.m. to 5 p.m.

## Price

All prices, packaging costs and delivery conditions for orders inside and outside Germany can be found here (always up to date):

**[www.cp.de/en/services/our-logistics-move-steel-cabinets-safely/](http://www.cp.de/en/services/our-logistics-move-steel-cabinets-safely/)**



# Leading the way in corrosion protection, quality assurance and environmental protection



For almost 100 years, products from C+P have been known for their high quality standard.

Environmental protection is a key issue when it comes to painting at C+P. We rely on German-made paint products. Our paint suppliers are certified according to EMAS, ISO 9001, ISO 14001, ISO 45001 and IATF. We work in a sustainable way and use only VOC-free paints in efficient systems.

We're able to meet our customers' color needs through continual quality testing during the coloration process. We offer high-quality enamel coating with robust, environmentally friendly immersion and powder coating systems for high light resistance. C+P's coatings follow the RAL color register. Thanks to continual system monitoring and color analytics in accordance with the RAL 840-HR color register, this level of quality is ensured for the long term.



State-of-the-art production systems at C+P



Immersion painting at C+P

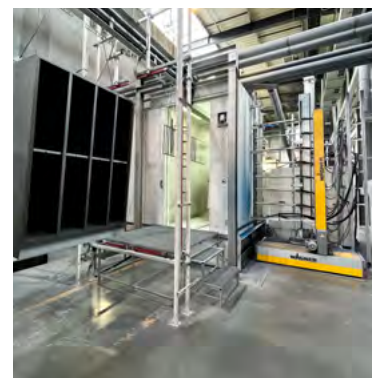

Powder coating at C+P

## Corrosion protection classes according to the C+P company standard

Corrosion protection classes	Class I Dry zones	Class II Damp zones
	Furniture to be set up in dry rooms with average ventilation*	Furniture for rooms with increased humidity
Version	Coated sheet metal	Sheet metal electrolytically zinc plated and powder coated
Coating	High quality enamel coating	High quality enamel coating
Approved cleaning agents	The original C+P cleaner	The original C+P cleaner
Guarantee	10-year guarantee against rusting through	10-year guarantee against rusting through
Additional charges	No additional charge, as C+P standard	See catalog/www.cp.de/en.

\*When using the lockers in public areas in which the increased use of road salt is to be expected during the winter months, we recommend using the electrolytically zinc-plated sheet metal and shoe trays.

**The classifications apply to all corrosion protection classes only when the surface is undamaged.**

Note: Corrosion-protected locks for wet areas can be found on our accessory pages.





#### C+P the cleaner

Guarantees optimal surface cleaning of your C+P locker.  
**Item no. 99699-00000**

- + Cleans without leaving residue or streaks
- + For automated and manual cleaning
- + Reliably and quickly removes dust, fingerprints and light oil soiling
- + Easy, safe and ready to use
- + Made in Germany

#### Application:

Spray cleaner onto the steel surfaces and then wipe off with a soft cloth or soft paper.

Safety data sheet available at [www.cp.de/en](http://www.cp.de/en).



#### Quality assurance at C+P

In order to maintain and expand our quality standard, continual testing and experimentation are required. At our **in-house laboratory** and in the adjacent testing chamber, we test more than just product details—we test the entire product. The latest scientific testing methods are applied here. One important criterion requiring constant monitoring is the surface and corrosion protection, particularly for our steel lockers.

#### The following testing methods are regularly used at the C+P testing laboratory

- + Load and bay load of components and lockers (up to 4,500 N)
- + Long-term durability of drawers and pull-outs through at least 50,000 opening and closing cycles
- + Door opening overextension test (up to 190° opening angle)
- + Durability of structural connections
- + Continual loading and service life
- + Surface quality
- + Drying behavior in lockers

DIN 50021	Salt spray test with subsequent inspection as per DIN 53167
DIN 50017	Condensation test with subsequent inspection according to DIN 53209
DIN 53151	Cross-cut adhesion test
DIN 67530	Evaluation of gloss
DIN 53153	Buchholz indentation resistance test
DIN 5033	Colorimetry



Price per bottle incl. spray head:  
 See price list



Contents:  
 500 ml









# Our references

As a market-leading furniture manufacturer of changing room and assembled box locker solutions, C+P isn't just an absolute professional when it comes to interior design—our comprehensive product range offers solutions for the office, archiving, greening and climate control, as well as warehouse and workshop equipment. C+P is a full-service provider accompanying its customers from initial planning to delivery and installation to after-sales service, thereby ensuring a smooth overall process. On the following pages, we present a selection of our references.

# Schneider GmbH & Co. KG



SCHNEIDER is one of the world's leading suppliers of processing solutions to the eyeglass and precision-optics industry. The company is headquartered in Fronhausen (Marburg), Germany with additional branches in the US, Brazil, Hong Kong and Thailand.

The company's success and that of their customers is ensured by high-quality machines, innovative technological concepts and networked production solutions. The fascination with innovation becomes tangible the minute you enter the headquarters.

The company's headquarters, on a floor space of over 9,500 m<sup>2</sup>, are characterized by state-of-the-art climate and heating technology as well as communication and media technology, modern demonstration and training rooms and ergonomically optimized workstations.

People form the heart of a company, and their commitment is the pulse. To foster enthusiasm for innovation, emphasis was placed on a working environment which meets various needs. The result is a unique building that promotes well-being and creates space for new ideas.

The team offices are generously laid out and spacious with a view of the outside grounds, but still allow for privacy thanks to the layout of the double workstations. The furnishings—kept in white with black accents—underline the friendly effect of the space. The intelligent integration of technology allows for the easy reach of connections which can be stored neatly in the cable trough.





Company

Color concept



Many offices, including those of the divisional management, can be used for spontaneous meetings in addition to their function as workstation. Brief meetings can be held at the mobile occasional tables. They're also ideal for quickly extending the work surfaces with flexible sit/stand solutions.

Changing room & wardrobe



Workshop & factory



Office & archive



# Bucharest thermal bath



The Bucharest thermal bath is setting standards nationally and internationally. The investor's requirements were correspondingly high for the top-quality changing rooms, which were designed to reflect the uniqueness of the overall complex in their materials and function.



The Prefino series with its highly flexible steel body was used, which allows all cable routing to be cleverly integrated into the slanted roofs of the lockers.

The decision was made for glass doors that require no visible fittings, creating a completely smooth and elegant external front.

Prefino assembled box lockers make optimum use of the interior space available in the changing room system, enabling user capacity to be utilized to the full. The combination with the existing natural marble base creates harmonious interplay among the various components and materials.

The base highlights the fine design of the interior fittings while serving as a practical bench.





The changing cubicles with floating appearance blend in perfectly with the room's stylish design.



Inspired by the Erding thermal bath in Germany, the Bucharest thermal bath is one of Europe's largest thermal springs. A spa complex with a tropical twist was built in an area totaling 25,000 m<sup>2</sup>.

It's a popular destination both nationally and internationally thanks to its central location. The thermal bath has three themed areas to meet the varied needs of its visitors. They can find relaxation in the jacuzzis and aromatherapy pools at The Palm. Six saunas, sunbathing areas and massage areas invite visitors to relax in the Elysium.



# UCLA Wasserman Football Center

## Changing room and assembled box locker solutions for players, coaches and employees.



The newly built Wasserman Football Center of the University of California, Los Angeles (UCLA) gives players and coaches a modern training environment with unrestricted access to the latest football equipment over an area of 7,000 m<sup>2</sup>.

Custom storage space solutions for the players, coaches and employees which harmoniously fit into the design concept of the Wasserman Football Center had to be created for the changing room and assembled box locker areas.

### Requirement: Custom storage area solutions for different user groups

As a market-leading furniture specialist in changing room and assembled box locker solutions, C+P was able to impress the customer with its custom solutions. High-quality lockers and assembled box lockers of the Prefino product series tailored to the individual wishes of the customer were used.

#### A pleasant atmosphere in the changing room

Optimally adjusted to suit the needs of players, the football lockers not only feature technical details but also meet the high design standards of the Wasserman Football Center. Thanks to the harmonious design of the changing room, a space has been created for football players that will positively affect their mood, passion to win and team spirit. In addition to the lockers, the changing area includes a spacious lounge zone that functions as a meeting point for communication and recreation.

#### Football locker with bench and mirrored sides

Both the body and the underframe of the lockers are made of steel, a long-lasting material that conserves resources. Designed in accordance with customer requirements, the steel underframes can absorb high dynamic loads. The frame cladding also serves as a comfortable place for the players to sit. The sides, with a large mirrored area, frame the fold-in doors of the football lockers made of white solid-surface material that elegantly disappear into the body and provide rapid access to the locker interior.





## Personalized lockers for each player on the football team

Matching the consistent color concept of the rooms, the doors are marked with the individual player numbers in blue and gold. The numbers are attached to the door by means of punched holes and can be changed rapidly as required. Each locker also has a plaque personally naming the donors and supporters of UCLA. Four spacious drawers and one changing room rail per compartment offer sufficient space for clothing and shoes.

### Personal security compartments with electronic safety lock

Each player also has access to a high-quality security compartment fitted with an electronic safety lock to store personal items such as smartphones and jewelry. Each security compartment has a power supply and is equipped with a USB port.

### Player equipment distributed via the assembled box locker

The top-quality high-pressure laminate feed-through security compartments, also with milled numbering, contain the players' personal equipment. Clean clothing and helmets can be given to the players from the rear side via central doors. The player enters the PIN code via the electronic lock to open the security compartment.

### User-oriented storage space for coaches and staff

The equipment for the changing areas for coaches and staff, like that of the player lockers, is especially high-quality and perfectly suits the needs of the users. The trainer lockers contain three stainless steel drawers with pull-outs, with the top drawer functioning as a security compartment with PIN code lock, power supply and USB port. The staff locker area is fitted with fine HPL material in black. The doors can be opened via a PIN code lock and have been given milled numbering.



# University of Oregon

## Hatfield-Dowlin Complex, Oregon Football Performance Center.



The newest home of the Oregon Ducks, the football team of the University of Oregon, is a unique and visionary project which has yet to meet its match. The Football Performance Center follows a holistic concept combining architecture and interior fitting in order to perfectly tailor them to the needs of the players. Facades made of glass, granite and metal simultaneously convey both lightness and strength. What seems impenetrable and secretive from the outside is flooded with light and bright on the inside.

### Go Ducks!

“We wanted a locker which had never been seen before. C + P really succeeded in catching the ball and exceeding our expectations.”

(Randy Stegmeier, interior designer, Firm 151)





## The interior fittings are just as multifaceted

The attention to detail reflects the care taken during planning. The designers never lost sight of the actual focus of the project: the well-being of the players. Every aspect of their everyday life, from classes to dining to medical care to recreational activities were carefully considered, and everything was coordinated with everything else down to the smallest detail.



### Luxurious, high-efficiency and ergonomic equipment

The equipment is luxurious, yet still highly efficient and ergonomic. The whole concept is designed to attract the best players and to win the College Football National Championships with the Oregon Ducks team going forward.





# Munich Sparkasse



## The office of the future with C + P SmartLockers

A place of well-being. That's the first thing that comes to mind when entering the "new world of work" at the Sparkasse in Munich. In a pilot space of 750 square meters, the vision for the workplace of the future was implemented in the pavilion of the office tower. Part of this future is C+P SmartLockers. They fit stylishly into the wonderfully created ambiance in the entrance area.

After having supplied new lockers for the fitness changing cubicles at the Munich Sparkasse last year, C+P received an order for 80 C+P SmartLockers for the "new world of work" early this year, according to C+P Key Account Manager André Reis.



48 large compartments and 32 smaller ones were supplied for this visionary project and set up in the pilot space area. The time came in late May of 2022, when the first 55 employees moved into the new rooms. There are also eight trial employment spots for staff from other departments.

Since then, the SmartLockers have proven themselves to be perfect support for the office world of the future in every regard thanks to their flexible options for operation. “The strength of the SmartLocker lies primarily in its decentralized control and flexibility,” stressed Project Manager Moritz Seger. “Control is provided wherever it’s needed.”

The SmartLockers are the first place to go every morning and the last one every evening. Employees don’t just leave their personal belongings there, but their keyboard, headset, mouse and laptop when leaving their workstation as well. This facilitates smooth switching from a home office to in-person work at the office, as well as working in different places within the new office world.

“It’s very practical to be able to open a compartment for a colleague from your desk,” said Martina Seidel, who was impressed with object management. She’s been working permanently in the pilot area since the end of May. She likes keyless security compartments much better. She also finds her new environment to be very comfortable and likes the color and spatial concept very much. “You can work in a much more peaceful environment and with greater focus, while still being closer to colleagues,” reported the employee, who uses one of the large SmartLockers herself. She’s pleased that the large compartments have been outfitted with an additional shelf, which allows her to make even better use of the space there.



The office of the future is here today, including all its opportunities and possibilities. This also includes the option of using the locker compartments in a more flexible way. “Up until now, every employee has had their own compartment,” explained André Reis. “If this is changed over the long term, the number of compartments can be reduced by 10 to 15 percent.”

As Florian Seidl sees things, the options presented by C+P lockers are nowhere near exhausted: “In the short amount of time available, we haven’t explored it in depth at all. There’s still so much potential there.”







Trend products →

# Trend products

---

The products we present to you on the following pages go far beyond our motto, “the steel locker.” They feature optimal solutions for meeting the needs of long-term trends and developments.

A world where keys are no longer important? A box which opens precisely when its moment has come? Dividing rooms without separating them? Designing working environments motivated by the “biophilic design” principle? It’s all possible with C + P.

Discover innovative solutions which have already been tried and tested in practice many times.



# Your doorway to a magically efficient time C + P SmartLockers.

A world where keys aren't important. A compartment which opens precisely when its moment has come. Objects which appear behind a different door than they did yesterday. What seems to be magic—like any stage show—is actually sophisticated technology. Our SmartLockers differ from typical magic tricks in one way, though: Their primary purpose isn't to fool and entertain, but to make workflows at your company smarter and more efficient. This saves you time, space and money, allowing you and your team to concentrate on your own tasks. It also means that cabinets are no longer just a passive storage place, but rather a true asset of your organization. But can't they be fun, too? Open the curtain for the new C + P SmartLockers...



## The advantages to you at a glance:

- + Reduces costs: You don't need to acquire a separate compartment for each employee
- + Productivity: Familiar complications due to lost keys etc. are a thing of the past
- + Saves time: Bothering and distracting transfer situations are no longer an issue
- + Source of income: Compartments can earn you money with pay/rent functions
- + Compatibility: C+P SmartLockers can be connected to a wide variety of different networks
- + Individuality: Flexible configuration for your needs thanks to a modular system
- + Convenience: Lockers can be individually arranged with one another as a locker wall
- + Usability: For social spaces, contactless transfer, employee mail, as a meeting point etc.
- + Independence: The doors can still be opened even in case of a power failure
- + Full service: At C+P, you get everything from a single source: locker, software and support

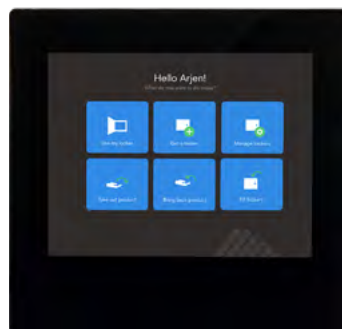
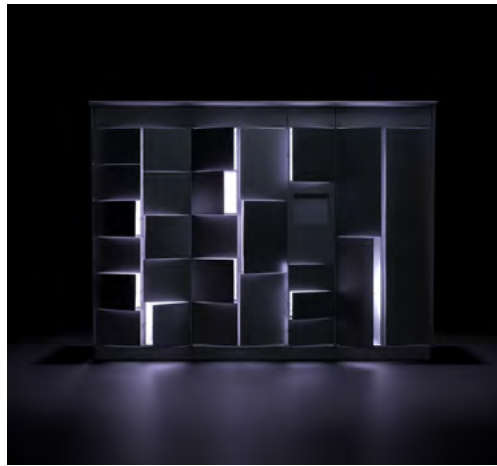

Compartments can be opened and information on the contents provided using the screen



# Dividing rooms without separating them

## C + P partitions.



## C + P Monotop<sup>®</sup>

### Classy transparency.

Create generous width for the latest office architecture with the transparent and sophisticated design of our unique C + P Monotop partition system. With all the advantages of a relocatable partition system, no less. C + P Monotop impresses with its outstanding design, in particular the elegant connection between two glazing segments. The connection principle of the new segment design requires only the installation space in the 6 mm-wide shadow gap. This means that the visible post width of glazed structures is only 28 mm!

Attractive room-in-room solutions in modern office landscapes are on the rise, whether as a think tank for concentrated working and conferring or as a solo office with consultation spaces. Combination office concepts with individual offices and a central zone “marketplace” demand creative and flexible room solutions.

With C + P Monotop, you can create the ideal basis for the successful implementation of these trendy office structures and remain flexible for the future. There are no limits to the design: Classic hinged doors, or rather the elegant sliding door? Full transparency, frosted glass or even “matte glass at the push of a button” with electrically controlled liquid crystals? From the classic think tank to high-tech room solutions, C + P Monotop opens up every possibility.



C + P Monotop room-in-room solutions aren't just limited to wall systems. From RGB-lit stretch ceilings to the integration of media technology, we've thought of everything with Monotop.



# C + P Light

## Modern glass architecture.



Extension grids, planning, acoustics and style—partition systems involve them all. To make the right choices in all these areas, there's one thing that comes before everything else: experience.

C + P has been manufacturing partitions for more than 40 years. A team of experienced product specialists stand ready to assist you with competent consultation and planning.



Features of modern architecture, as well as many office concepts, include great clarity and openness of the rooms being designed. C + P Light—glass to glass—creates maximum transparency.

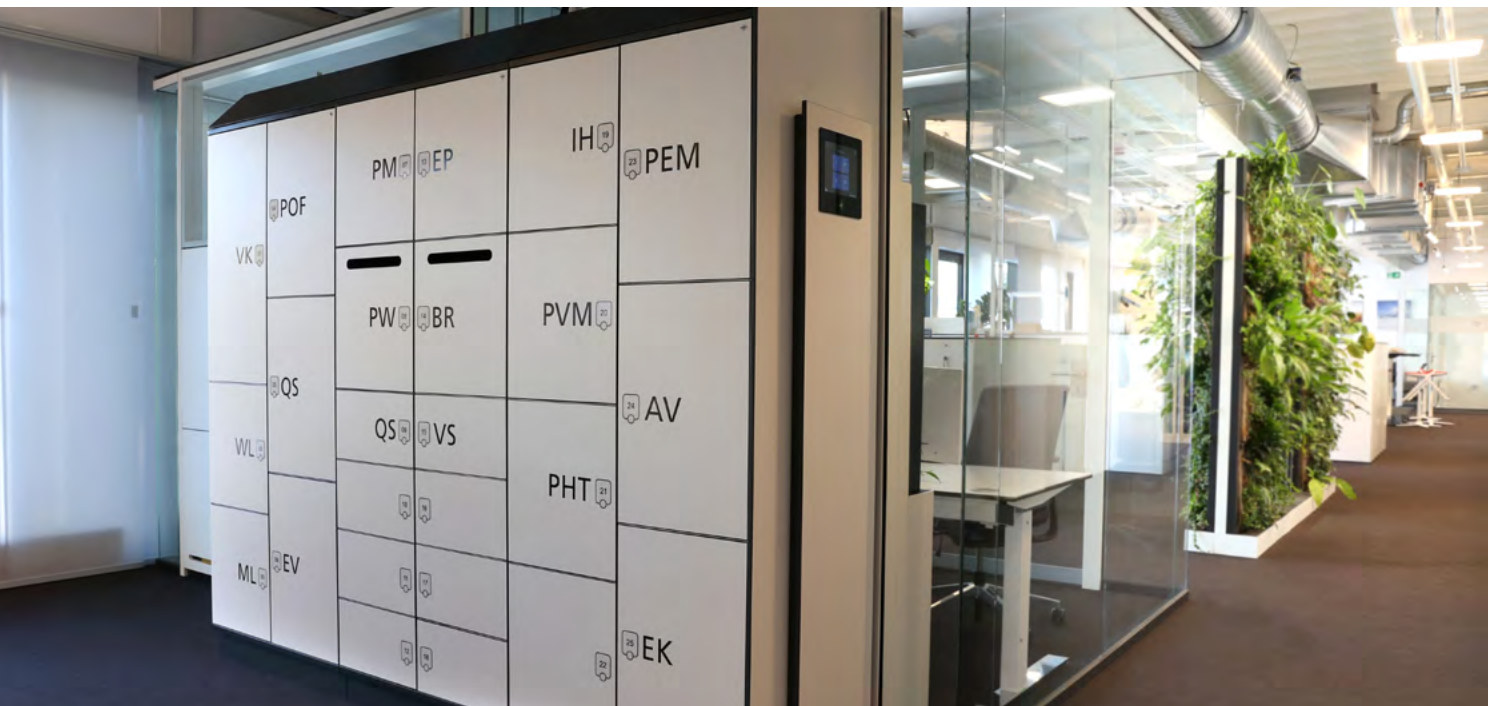



# Climate Office – Shaping rooms according to the biophilic design principle



## Climate Office, as an approach based on biophilic design principles

Based on the principles of biophilic design, C+P has developed holistic and sustainable furniture solutions for air purification, greening, climate and acoustics with “Climate Office.” Central themes here include:

- + Room climate optimization
- + Increasing personal well-being

## Increasing well-being and motivation at the workplace

In combination with plants and water, these future-oriented products made of steel—a resource-conserving material—ensure an optimal comfort level on the interior. Biophilic design principles can make a decisive contribution to greater motivation and less sick leave.

### **Advantages:**

- + Healthy air humidity
- + Improved cognitive features
- + Purified air

## Custom C + P green walls Implementation of various different customer projects



Looking for custom wall greening?  
No problem! Feel free to contact us!  
We can also design custom green  
walls tailored to your wishes and  
needs. Gain inspiration from existing  
customer projects.

### ^ GÜNTHER Heißkanaltechnik

The green wall is a true eye-catcher  
in light-flooded administrative buildings.  
A direct view of the yard also enhances  
the experience of nature on the interior.



### ^ ROTH Energie

Arrive and feel at ease—the bright reception counter,  
in combination with custom green walls, is especially  
inviting. Optimally integrated into the green wall, even  
the screen behind the counter is an attention-grabber.



### << Sparkasse Biedenkopf

Nature within a developed environment—the  
plants fit perfectly into this modern spatial  
concept. Shapes, colors and the interior form a  
design unit and lend the room its own character.







To color concept →

# The new C + P color concept

For decades, C+P has made a name for itself with the motto “Show your colors.” It’s said that better is the enemy of good, so our **new color concept** not only features trendy and attractive colors for every environment, but greatly simplifies our **color surcharge system** as well. Most of the time you won’t need it anyway, as we’re now offering 144 colors and color combinations **at no additional charge**.



# C + P color moods and effects

Not everything in life has to be gray! This page includes examples of color moods you can compose with the C+P color pallet however you like. You can use it to create elegant, clean, harmonious or nature-oriented room atmospheres any way you wish.

**Just this handful of examples shows how C+P makes steel as beautiful as it can be.**



VIDAR  
Natural



LUIN  
Energizing



-   
Pearl white  
RAL 1013
-   
White green  
RAL 6019
-   
Reseda green  
RAL 6011
-   
Pure green  
RAL 6037
-   
Anthracite gray  
RAL 7016

-   
Architecture blue  
RAL 240 60 15
-   
Gentian blue  
RAL 5010
-   
Anthracite gray  
RAL 7016
-   
Distant blue  
RAL 5023
-   
Light gray  
RAL 7035

# Color innovations for the furnishings of tomorrow



VARM  
Warming



AMON  
Fortified

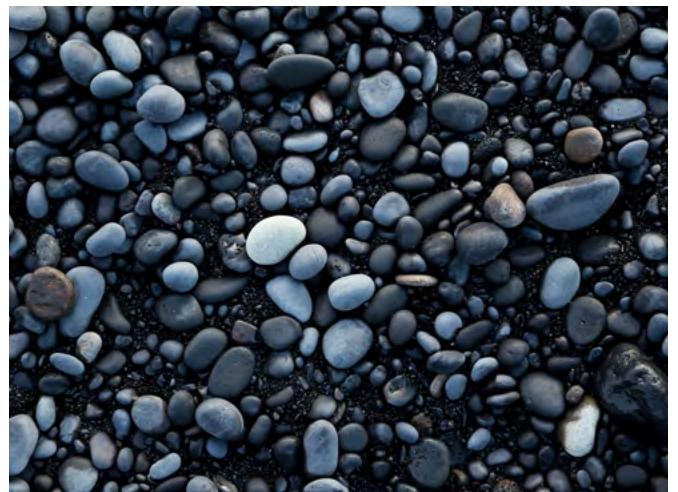

Fire red  
RAL 3000



Traffic yellow  
RAL 1023



Pure orange  
RAL 2004



Traffic red  
RAL 3020



Light ivory  
RAL 1015



Light gray  
RAL 7035



Light ivory  
RAL 1015



Steel gray  
RAL 000 50 00



Anthracite gray  
RAL 7016



Deep black  
RAL 9005



# Color concept

## Color group 0

Body and front colors with no surcharge

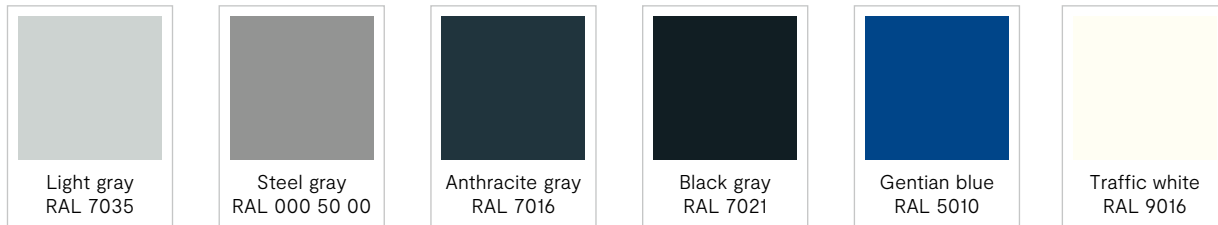

## Color group 1

Surcharge for bodies/No surcharge for fronts

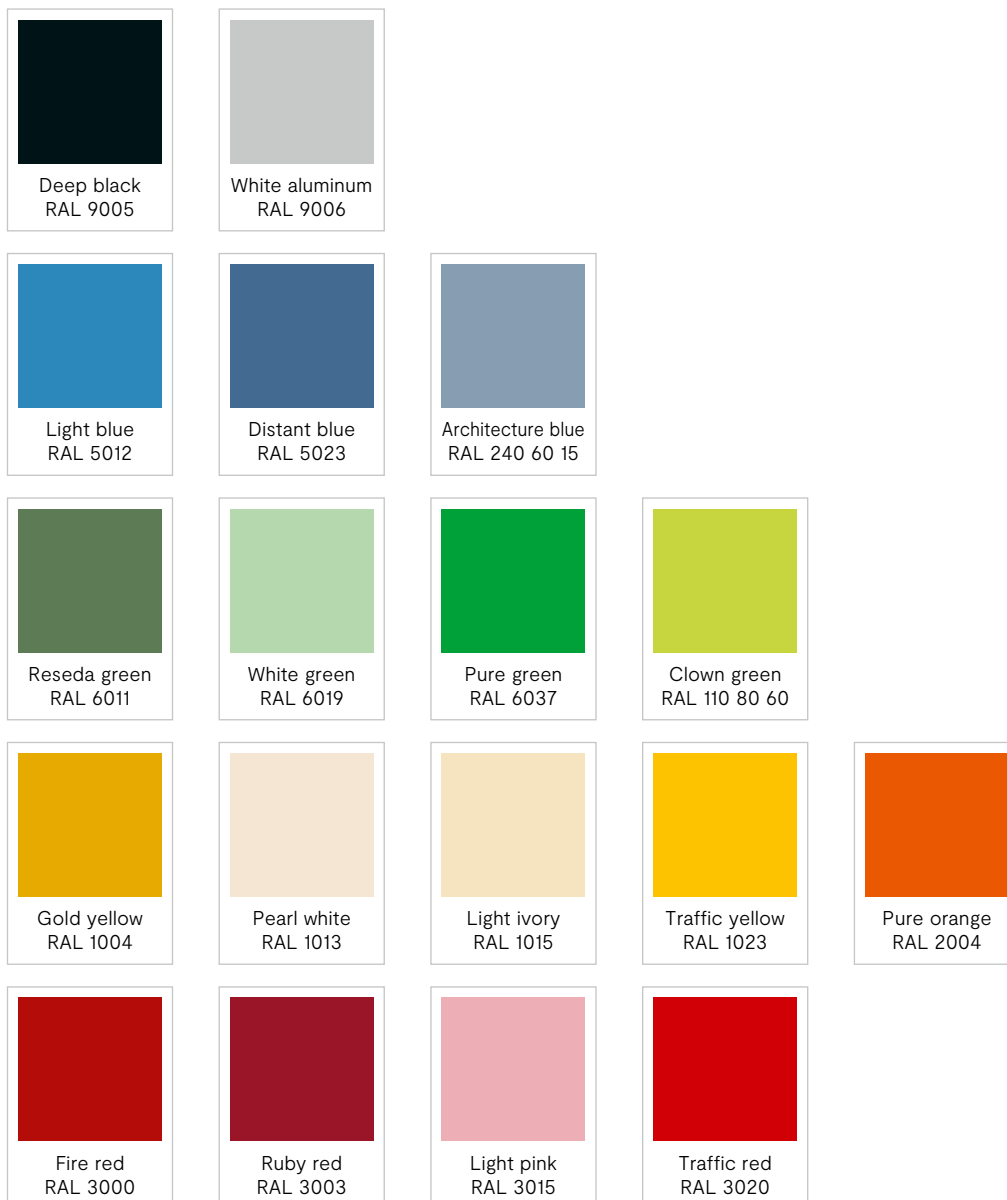

# Expert paint work



## No surcharge!

With the C+P color concept, 144 color combinations are available at no additional charge.

**For body colors of color group 0, all front colors of the color concept are available with no surcharge.**



## Lots of color, not a lot of money.

**For body colors of color group 1, the additional charge for color is 15%.**

This enables you to make exciting worlds of color a reality without putting too much strain on your budget.



## Special colors? Absolutely!

Paint finishes in all RAL colors outside the C+P concept are also possible.

**The color surcharge for this is 25% (minimum order: 5 lockers).**

Subject to technical testing and availability.

Feel free to send us your requests.

### Important notes:

These color charts are intended solely as a guide to the approximate impression of the colors. For more exact color representations, please consult the RAL color chart or the original samples. Colors are subject to deviation and do not constitute grounds for complaint. We cannot accept any liability for printing and representation errors or flaws. All depicted decors, colors and surfaces are available as standard. Other versions (e.g., for contract furnishing) are available on request. The color surcharge system on page 48/49 applies only to furniture where the body and fronts are each coated in a **single** color. For other variants (e.g., different front colors on the same cabinet), please let us know your specific project details. **Please note that various product groups have their own selection of colors and** are not coated according to the C+P color concept. You can recognize the respective products by the individual color information provided on the respective pages of the catalog. Underframes are supplied in black gray as standard. We always coat shelves, hanging frames etc. in light gray, unless otherwise specified in the product series. Zinc-plated shelves are uncoated. For the color **RAL 9006 White Aluminum**, the RAL Institute has no uniform template and definition so that, despite having the same name, there may be color differences when compared to other materials, previous production batches, different coating procedures or third-party products.



## C + P decor fronts

- + HPL (high-pressure laminate) is available with a classic wood look or in single colors.
- + HPL is scratch-proof, non-porous and impresses with its high stability.
- + The door is 100% moisture-resistant and features outstanding hygiene properties!
- + MDF (medium-density fiberboard) decors are also available.



Evolò PLUS  
Body: RAL 7016 anthracite gray  
Doors: Sereno oak



Evolò PLUS  
Body: RAL 7016 anthracite gray  
Doors: Natural silver spruce

## Decor fronts (MDF)

With 18 mm black edging

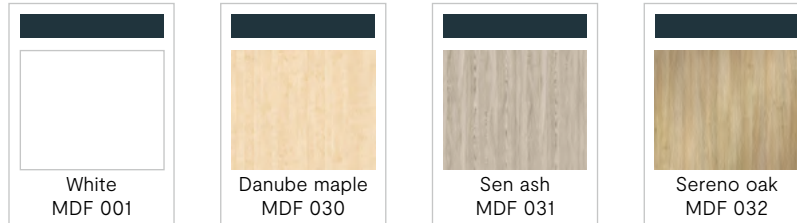

## Solid-core decor fronts (HPL)

With 13 mm black solid-core edge



### Important note:

All of the specified decors within a top type are available with no surcharge!

The birch gray VK 741 decor is similar to light gray.

The core of the HPL top is always black.





# C + P office furniture decors

Add a special touch with wood decors. Whether it's classic maple, acacia or light gray or a more modern appearance with a concrete look or in diamond white, add some color to your office! Choose between DBS decors (melamine coated particle board) for the respective occasional cabinet and table ranges and HPL decors (high-pressure laminate) for optional solid-core top covers of the Asisto steel cabinets.

## Important note:

All of the specified decors within a top type are available with no surcharge!

The birch gray VK 741 decor is similar to light gray.



## Decors (DBS)

With 25 mm edge band

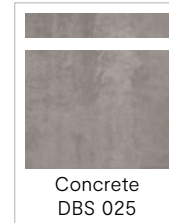
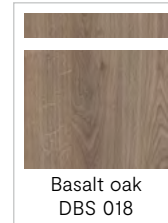
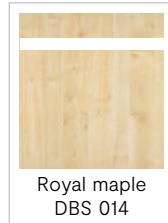
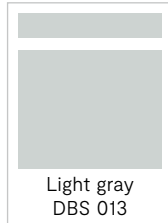

## Syncro decor tops (DBS)

With 25 mm edge band, only for tabletops of the Asisto sit/stand tables

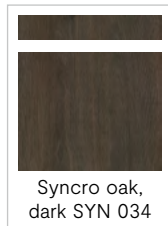
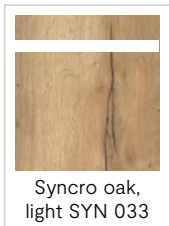

### Syncro decor

Is it real wood or a decor?

Syncro decors with light/dark oak impress with their incredible look and feel. The surface texture matches the grain, giving the impression of real oak. It not only looks real, but feels real, too!

## Solid-core top covers (HPL)

With 13 mm black solid-core edge

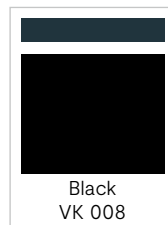
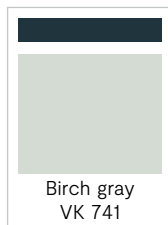
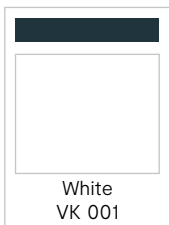









To the products →

# Changing room & wardrobe

C+P is the market leader in steel changing room systems and lockers. What's your furnishing task? C+P has the right solution for every application!

With innovative ideas like modern ventilation concepts and trend-setting locking systems, C+P sets new standards again and again.

# Changing room and wardrobe



# 60

Lockers  
Classic PLUS



# 98

Lockers  
Evolò PLUS



# 192

Assembled box lockers  
Intro/Resisto



# 220

stackable benches, benches  
and benches with coat rack  
Basic and Comfort



# 166

Lockers  
Cambio



# 186

Lockers  
Prefino



# 232

Wall-mounted and free-standing wardrobes, open wardrobes and assembled box lockers



# 242

Industry-specific and custom solutions



# Versatile and practical Steel lockers.



## Classic PLUS

### The classic locker with an industrial design

- + Complete range with steel doors
- + Break-in-resistant design as per class B according to DIN 4547-2
- + 661 models are available in this series
- + 2 compartment widths, 5 different box heights
- + Reinforced doors with ventilation gills and stamped-in label holders
- + Safety turning bolt for padlock (assembled box lockers with smooth doors and cylinder lock)
- + Compartment bottom can be swept out easily

**Available floor-standing, with feet, base or bench**



## Evolo PLUS

### The advanced locker with serious added value

- + Comprehensive range with steel doors, MDF or HPL
- + Especially break-in-resistant design as per class C according to DIN 4547-2
- + 708 models are available in this series
- + Level adjustment for all sub-frames as standard
- + 2 compartment widths, 6 different box heights
- + Reinforced doors with designer ventilation hole pattern and matching Comfort label holder, decor doors also available
- + Safety turning bolt for padlock (assembled box lockers with smooth doors and cylinder lock)
- + 90° door opening limiter as standard
- + Wide variety of interior fitting solutions for any requirement

**Available floor-standing, with feet, base or bench and in other versions, e.g. with built-in storage box**

	Locker heights without sub-frames	Compartment widths	Floor-standing locker	Locker with feet (H + 100 mm)	Locker with base (H + 100 mm)	Sub-frame bench	Storage box	Corrosion protection, fully zinc-plated	Corrosion protection via zinc-plated components
Classic PLUS	1530   1700   1850	250   300   400	●	●	●	●	—	—	●
Evolo PLUS	1530   1700   1850	300   400	●	●	●	●	●	—	●
Cambio	1850	300   400	—	●	●	●	—	●	—



Prefino project solutions → p. 186

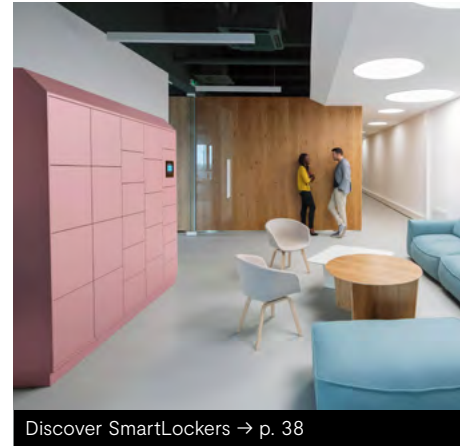

Discover SmartLockers → p. 38

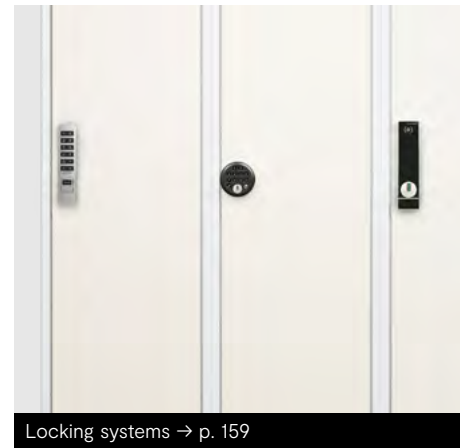

Locking systems → p. 159

## Cambio

### The elegant locker with overlay doors

- + Comprehensive range with steel doors (optionally double-walled) or HPL
- + Especially break in-resistant design as per class C according to DIN 4547-2
- + Body, base and steel doors electrolytically zinc-plated as standard
- + Standard ventilation using the SVL concept® (self-ventilation), optionally available with the FVL (forced ventilation) and FVLD concept (forced ventilation with dryer)
- + Level adjustment for all sub-frames as standard
- + 2 compartment widths, 6 different box heights
- + Smooth steel fronts (single-walled, optionally double-walled and insulated) or optional HPL with wood decor for an even more attractive look
- + Cylinder lock with 2 keys for each door
- + 90° door opening limiter as standard
- + Wide variety of interior fitting solutions for any requirement

**Available with feet or base, as well as with spacious storage box or bench on request**

	Steel fronts	Wood decor fronts	Integr. door opening limiter	Standard furnishing	Upscale furnishings	Electrification	Covered cable duct (lock/USB) available	Break-in resistance class*	SmartLocker-solutions
Classic PLUS	●	–	–	●	–	–	–	B	–
EvoLO PLUS	●	●	●	●	●	●	●	C	●
Cambio	●	●	●	●	●	●	–	C	–

# Versatility, security and utility

## The new Classic PLUS.

This model shows that the classics don't just ride the retro wave, but can reinvent themselves, too. It's predecessor, the C + P Classic, is known by many as a secure storage location for personal and valuable items at companies, schools and museums, for example, and this hasn't changed. What is different is the fresh design and variety of combination options and details—some of which are immediately apparent, and others only later on. We think its true utility is also expressed by the fact that it's subjected to the test bench and dynamically adapted to new conditions again and again.



Classic ventilation gills with stamped-in label holder



Anti-rotation and high-load-capacity double sliding hooks with special mounting, e.g. for hangers or retrofitted partitions

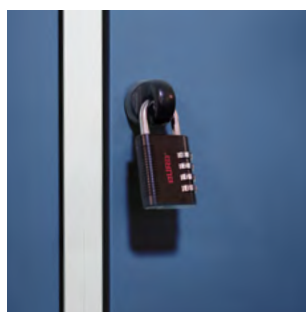

Safety turning bolt latch for padlock (turns while locked, thereby preventing break-in through over-turning), incl. door protection



## Rock-solid arguments

- + Sturdy steel construction with high-quality enamel coating
- + Bottom and locker floor generally zinc-plated for increased corrosion protection
- + Break-in-resistant design as per class B according to DIN 4547
- + 2 compartment widths, 5 different box heights
- + Reinforced doors, hinged on the right, with doorstop silencer, ventilation gills and label holder, as well as safety turning bolt latch for padlock (assembled box lockers with smooth doors and cylinder lock)
- + Single-tier lockers: Inside each compartment: 1 non-adjustable storage shelf with sturdy changing room rail below with 3 anti-rotation double sliding hooks (load capacity per rail: 40 kg, per double hook: 15 kg)
- + Double-tier lockers: Inside each box: 1 sturdy changing room rail with 3 anti-rotation double sliding hooks
- + Compartment bottom can be swept out easily
- + Slim lateral edges for a homogeneous look when lined up next to one another without doubling at the locker joints
- + Additional ventilation thanks to ventilation openings in compartment bottom and top as self-ventilation concept through structurally optimized air flow behavior

### Available floor-standing, with feet, base or bench

- + Plastic feet, base featuring increased corrosion protection, both for body RAL 7035 in light gray, otherwise in black gray
- + Optional level adjustment for floor-standing, feet or base
- + 420 mm-high bench frame made of square tubing in black gray, with 10 mm level adjustment, bench slats made of 60 x 25 mm beech, rounded on all sides, coated with clear varnish with natural color variations
- + 450 mm seat height, 315 mm seat depth
- + Bench and locker separate for easy DIY assembly



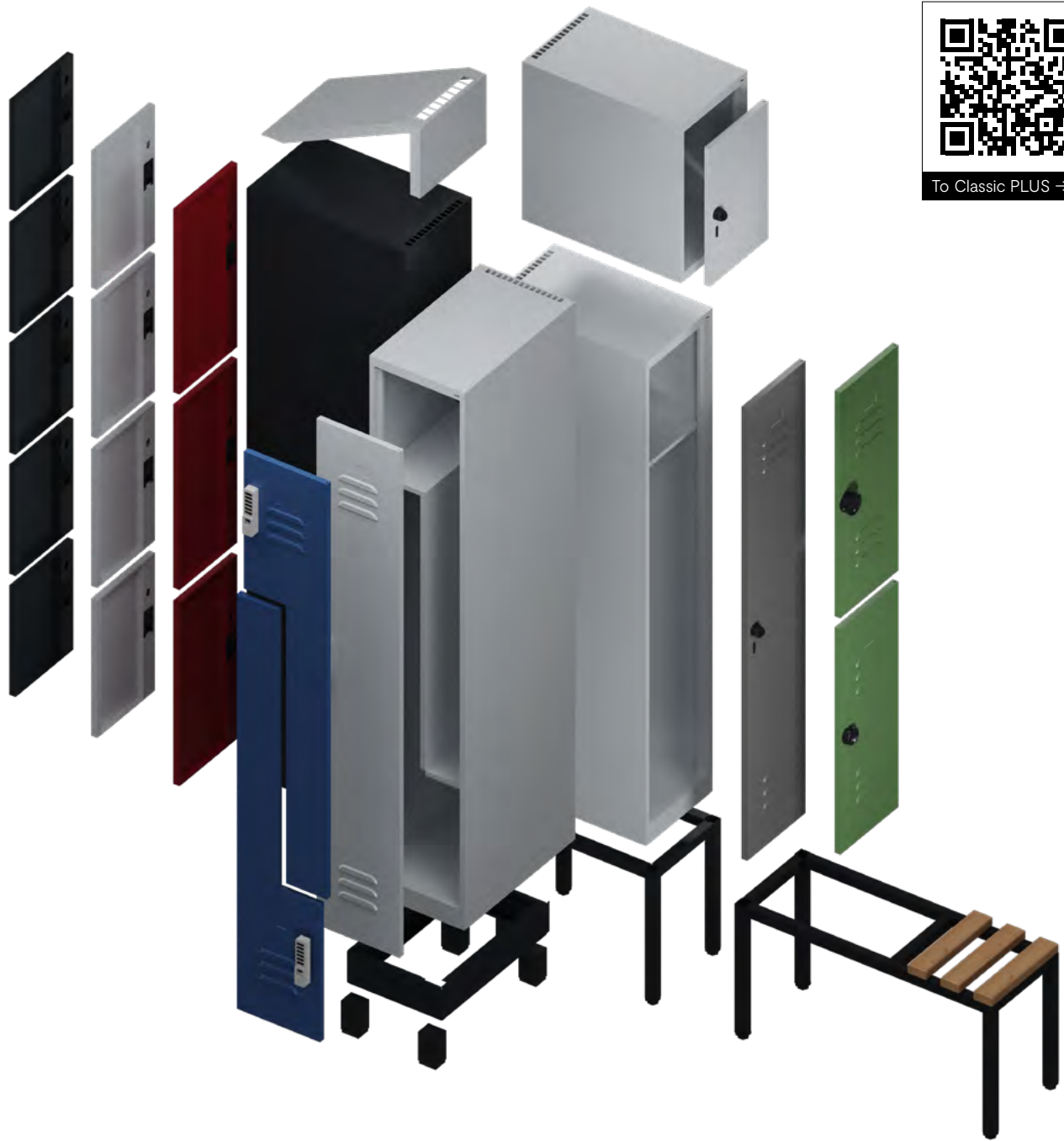

Company

Color concept

Changing room & wardrobe

Workshop & factory

Office & archive



Lockers  
→ p. 62



Multi-purpose  
lockers → p. 74



Double-tier lockers  
→ p. 76



Assembled box  
lockers → p. 80



Z lockers  
→ p. 88

# Classic PLUS

## Lockers with full-length door.



Order no. 080000-20



Order no. 080010-20



Order no. 080020-22

### Dimensions and design

With safety turning bolt  
Clear opening dimensions per door:  
1,749x240/340x477 (HxWxD)



#### Floor-standing

Locker height: 1,850  
Locker depth: 500

Compartments	1x300	2x300	3x300
Locker width	300	600	900
Order no.	080000-10	080000-20	080000-30
Price			

#### With feet

Locker height: 1,950  
Locker depth: 500  
Foot height: 100

Compartments	1x300	2x300	3x300
Locker width	300	600	900
Order no.	080010-10	080010-20	080010-30
Price			

#### With base

Locker height: 1,950  
Locker depth: 500  
Base height: 100

Compartments	1x300	2x300	3x300
Locker width	300	600	900
Order no.	080020-10	080020-20	080020-30
Price			

→ Body and door color

Color concept → p. 48



Slim lateral edges for a homogeneous look when lined up next to one another without doubling at the locker joints



Compartments	4 x 300	1 x 400	2 x 400	3 x 400
Locker width	1200	400	800	1200
Order no.	080000-40	080000-12	080000-22	080000-32
Price				

Compartments	4 x 300	1 x 400	2 x 400	3 x 400
Locker width	1200	400	800	1200
Order no.	080010-40	080010-12	080010-22	080010-32
Price				

Compartments	4 x 300	1 x 400	2 x 400	3 x 400
Locker width	1200	400	800	1200
Order no.	080020-40	080020-12	080020-22	080020-32
Price				

**+** Accessories (optional)

Selection → p. 94



# Classic PLUS

## Lockers with partition.

### Space-saving solution for the separation of street and work clothing

Inside each compartment: 1 non-adjustable storage shelf, fixed steel partition below and sturdy changing room rail with anti-rotation double sliding hooks.



Order no. 080000-22F



Order no. 080010-22F



Order no. 080020-22F

### Dimensions and design

With safety turning bolt  
Clear opening dimensions per door:  
1,749 x 340 x 477 (HxWxD)



#### Floor-standing

Locker height: 1,850  
Locker depth: 500

Compartments	1x400	2x400	3x400
Locker width	400	800	1200
Order no.	080000-12F	080000-22F	080000-32F
Price			

#### With feet

Locker height: 1,950  
Locker depth: 500  
Foot height: 100

Compartments	1x400	2x400	3x400
Locker width	400	800	1200
Order no.	080010-12F	080010-22F	080010-32F
Price			

#### With base

Locker height: 1,950  
Locker depth: 500  
Base height: 100

Compartments	1x400	2x400	3x400
Locker width	400	800	1200
Order no.	080020-12F	080020-22F	080020-32F
Price			

→ Body and door color

Color concept → p. 48



Order no. 0800507-22F



Order no. 0800507-32F

### Variant: Hardwood bench slats

#### Dimensions and design

Locker height: 2,120  
 Seat height: 450  
 Seat depth: 315  
 Clear opening dimensions per door:  
 1,599 x 340 x 477 (H x W x D)

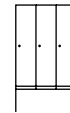
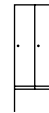
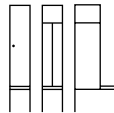

#### With bench built underneath the locker

Locker depth, incl. bench: 815

	Compartments	1x400	2x400	3x400
	Locker width	400	800	1200
	Order no.	0800507-12F	0800507-22F	0800507-32F
	Price			

Bench slats for models mentioned above made of beech hardwood as standard, rounded on all sides, coated with clear varnish with natural color variations. Standard color of the bench underframes is black gray RAL 7021. Absolute body height of lockers on bench or frame: 1,700 mm.

Locker and bench are delivered separately for easy DIY assembly.



Other locker variants with partition (e.g. compartment width of 300 mm, floating bench, plastic bench slats and lots more) available as standard—we're looking forward to receiving your request.

**+ Accessories (optional)**

Selection → p. 94

# Classic PLUS

## Lockers with bench.

Bench slats for models mentioned below made of beech hardwood as standard, rounded on all sides, coated with clear varnish with natural color variations. Standard color of the bench underframes is black gray RAL 7021. Absolute body height of lockers on bench or frame: 1,700 mm.

Locker and bench are delivered separately for easy DIY assembly.

### Variant: Hardwood bench slats

#### Dimensions and design

Locker height: 2,120  
 Seat height: 450  
 Seat depth: 315  
 Clear opening dimensions per door:  
 1,599x240/340x477 (HxWxD)

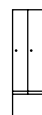

#### With bench built underneath the locker

Locker depth, incl. bench: 815

Compartments	1x300	2x300	3x300
Locker width	300	600	900
Order no.	0800507-10	0800507-20	0800507-30
Price			

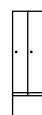
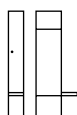

#### With floating bench

Locker depth, incl. bench: 815

Compartments	1x300	2x300	3x300
Locker width	300	600	900
Order no.	0800407-10	0800407-20	0800407-30
Price			

⚠ Wall mounting required!

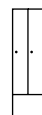
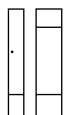

#### Flush with frame underneath

Locker depth, incl. frame: 500

Compartments	1x300	2x300	3x300
Locker width	300	600	900
Order no.	0800307-10	0800307-20	0800307-30
Price			

#### Optional

Clear height above shoe rack: 225

Order no. of shoe rack	+ 08050-70110	+ 08050-70120	+ 08050-70130
Add. charge for shoe rack			

#### → Body and door color

Color concept → p. 48

⚠ Upon request, frames also available in RAL 7035 or RAL 9016





Order no. 0800507-20



Order no. 0800407-30



Order no. 0800307-32  
& 08050-70132

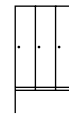
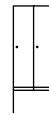
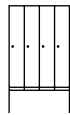

Compartments	4 x 300	1 x 400	2 x 400	3 x 400
Locker width	1200	400	800	1200
Order no.	0800507-40	0800507-12	0800507-22	0800507-32
Price				

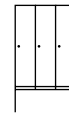
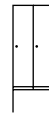
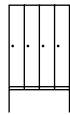

Compartments	4 x 300	1 x 400	2 x 400	3 x 400
Locker width	1200	400	800	1200
Order no.	0800407-40	0800407-12	0800407-22	0800407-32
Price				

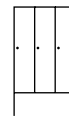
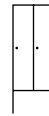
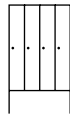

Compartments	4 x 300	1 x 400	2 x 400	3 x 400
Locker width	1200	400	800	1200
Order no.	0800307-40	0800307-12	0800307-22	0800307-32
Price				

+ Order no. of shoe rack	+ 08050-70140	+ 08050-70112	+ 08050-70122	+ 08050-70132
+ Add. charge for shoe rack				

+ Accessories (optional)

Selection → p. 94

# Classic PLUS

## Lockers with bench.

Bench slats for models mentioned below made of plastic with zinc-plated steel core for optimum stability. Plastic bench slats are more hygienic and easier to clean. Standard color of the bench underframes is black gray RAL 7021. Locker and bench are delivered separately for easy DIY assembly. Absolute body height of lockers on bench or frame: 1,700 mm.



Order no. 0800507-30 & 08530-7035

### Variant: Bench slats made of plastic

#### Dimensions and design

Locker height: 2,120  
 Seat height: 450  
 Seat depth: 315  
 Clear opening dimensions per door:  
 1,599 x 240/340 x 477 (H x W x D)

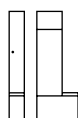

#### With bench built underneath the locker

Locker depth, incl. bench: 815

Compartments	1x 300	2x 300	3x 300
Locker width	300	600	900
Order no.	0800507-10 + 08510	0800507-20 + 08520	0800507-30 + 08530
Color no. for light gray	-7035		
Color no. for white	-9016		
Color no. for black gray	-7021		
Price			

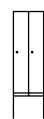

#### With floating bench

Locker depth, incl. bench: 815

ⓘ Wall mounting required!

Compartments	1x 300	2x 300	3x 300
Locker width	300	600	900
Order no.	0800407-10 + 08510	0800407-20 + 08520	0800407-30 + 08530
Color no. for light gray	-7035		
Color no. for white	-9016		
Color no. for black gray	-7021		
Price			

#### Optional

Clear height above shoe rack: 225

+ Order no. of shoe rack	+ 08050-70110	+ 08050-70120	+ 08050-70130
+ Add. charge for shoe rack			

→ Body and door color

Color concept → p. 48



Order no. 0800507-30 & 08530-9016



Order no. 0800407-20  
& 08520-7035



Order no. 0800507-32 & 08532-7021  
& 08050-70132

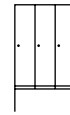
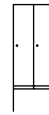
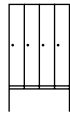

Compartments	4 x 300	1 x 400	2 x 400	3 x 400
Locker width	1200	400	800	1200
Order no.	0800507-40 + 08540	0800507-12 + 08512	0800507-22 + 08522	0800507-32 + 08532
Color no. for light gray	-7035			
Color no. for white	-9016			
Color no. for black gray	-7021			
Price				

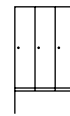
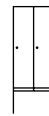
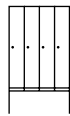

Compartments	4 x 300	1 x 400	2 x 400	3 x 400
Locker width	1200	400	800	1200
Order no.	0800407-40 + 08540	0800407-12 + 08512	0800407-22 + 08522	0800407-32 + 08532
Color no. for light gray	-7035			
Color no. for white	-9016			
Color no. for black gray	-7021			
Price				

+ Order no. of shoe rack	+ 08050-70140	+ 08050-70112	+ 08050-70122	+ 08050-70132
+ Add. charge for shoe rack				

+ Accessories (optional)

Selection → p. 94



# Classic PLUS

## Lockers with pairs of doors closing in the middle.

For the joint locking of two compartments for use by one person, e.g. for the separate placement of **street and work clothing**. Bench slats made of beech hardwood as standard, approx. 60x25 mm profile, rounded on all sides, coated with clear varnish with natural color variations. Plastic bench slats available at no additional charge. Standard color for the bench underframe: black gray RAL 7021. Absolute body height of lockers on bench or frame: 1,700 mm. Locker and bench are delivered separately for easy DIY assembly.

### Dimensions and design

With safety turning bolt  
 Clear opening dimensions per door:  
 1,749 x 240/340 x 477 (HxWxD)  
 With frame: 1,599 x 240/340 x 477 (HxWxD)



Floor-standing	Compartments	2 x 300	4 x 300	2 x 400
Locker height: 1,850	For no. of persons	1	2	1
Locker depth: 500	Locker width	600	1200	800
	Order no.	080002-20	080002-40	080002-22
	Price			

With feet	Compartments	2 x 300	4 x 300	2 x 400
Locker height: 1,950	For no. of persons	1	2	1
Locker depth: 500	Locker width	600	1200	800
Foot height: 100	Order no.	080012-20	080012-40	080012-22
	Price			

With base	Compartments	2 x 300	4 x 300	2 x 400
Locker height: 1,950	For no. of persons	1	2	1
Locker depth: 500	Locker width	600	1200	800
Base height: 100	Order no.	080022-20	080022-40	080022-22
	Price			



Flush with frame underneath	Compartments	2 x 300	4 x 300	2 x 400
Locker height: 2,120	For no. of persons	1	2	1
Frame height: 420	Locker width	600	1200	800
Locker depth, incl. frame: 500	Order no.	0800327-20	0800327-40	0800327-22
	Price			

Optional		+ 08050-70120	+ 08050-70140	+ 08050-70122
Clear height above shoe rack: 225	Order no. of shoe rack			
	Add. charge for shoe rack			

→ Body and door color

Color concept → p. 48



Order no. 080002-20



Order no. 080022-22



Order no. 0800527-20  
& 08050-70120



Order no. 0800327-40  
& 08050-70140

### Variant: Hardwood bench slats

#### Dimensions and design

Locker height: 2,120  
 Seat height: 450  
 Seat depth: 315  
 Clear opening dimensions per door:  
 1,599 x 240/340 x 477 (H x W x D)

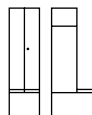

#### With bench built underneath the locker

Locker depth, incl. bench: 815

Compartment	2 x 300	4 x 300	2 x 400
For no. of persons	1	2	1
Locker width	600	1200	800
Order no.	0800527-20	0800527-40	0800527-22
Price			

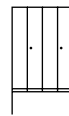

#### With floating bench

Locker depth, incl. bench: 815

⚠ Wall mounting required!

Compartment	2 x 300	4 x 300	2 x 400
For no. of persons	1	2	1
Locker width	600	1200	800
Order no.	0800427-20	0800427-40	0800427-22
Price			

#### Optional

Clear height above shoe rack: 225

+ Order no. of shoe rack	+ 08050-70120	+ 08050-70140	+ 08050-70122
+ Add. charge for shoe rack			

#### + Accessories (optional)

Selection → p. 94



Order no. 0800527-20  
& 08520-7035



Order no. 0800527-20  
& 08520-9016



Order no. 0800427-20  
& 08520-7035



Order no. 0800527-22  
& 08522-7021  
& 08050-70122

## Variant: Bench slats made of plastic

### Dimensions and design

Locker height: 2,120  
Seat height: 450  
Seat depth: 315  
Clear opening dimensions per door:  
1,599 x 240/340 x 477 (H x W x D)

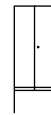

### With bench built underneath the locker

Locker depth, incl. bench: 815

Compartments	2x300	4x300	2x400
For no. of persons	1	2	1
Locker width	600	1200	800
Order no.	0800527-20 + 08520	0800527-40 + 08540	0800527-22 + 08522
Color no. for light gray	-7035		
Color no. for white	-9016		
Color no. for black gray	-7021		
Price			

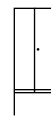

### With floating bench

Locker depth, incl. bench: 815

ⓘ Wall mounting required!

Compartments	2x300	4x300	2x400
For no. of persons	1	2	1
Locker width	600	1200	800
Order no.	0800427-20 + 08520	0800427-40 + 08540	0800427-22 + 08522
Color no. for light gray	-7035		
Color no. for white	-9016		
Color no. for black gray	-7021		
Price			

### Optional

Clear height above shoe rack: 225

+ Order no. of shoe rack	+ 08050-70120	+ 08050-70140	+ 08050-70122
+ Add. charge for shoe rack			

→ **Body and door color**

Color concept → p. 48

+ **Accessories (optional)**

Selection → p. 94

ⓘ All dimensions in mm, and all prices in Euros  
Frames also available in RAL 7035 or RAL 9016





When employees are exposed to strong odors or dirt, work and street clothing need their own separate compartments—i.e. “dirty/clean separation.” Classic PLUS masters this requirement of workplace regulations in a highly professional way.

Company

Color concept

Changing room & wardrobe

Workshop & factory

Office & archive

# Classic PLUS

## Multi-purpose lockers.

Doors closing in the middle with a joint turning bolt latch for padlock, shelves not adjustable.



Order no. 080600-20



Order no. 080100-02

### Dimensions and design

With safety turning bolt  
Clear opening dimensions per door:  
1,749x240/340x477 (HxWxD)



#### Floor-standing

Locker height: 1,850  
Locker depth: 500

Variant

##### Laundry locker

4 shelves on the left, storage shelf on the right with sturdy changing room rail with an oval profile and 3 anti-rotation sliding hooks

##### Cleaning supply locker

Reduced-size partition, 4 compartments on the left, sturdy rail with an oval profile on the right with 3 anti-rotation sliding hooks.

Compartments

2 x 300

2 x 400

2 x 300

2 x 400

Locker width

600

800

600

800

Order no.

080600-20

080600-22

080100-00

080100-02

Price

#### With feet

Locker height: 1,950  
Locker depth: 500  
Foot height: 100

Variant

##### Laundry locker

4 shelves on the left, storage shelf on the right with sturdy changing room rail with an oval profile and 3 anti-rotation sliding hooks

##### Cleaning supply locker

Reduced-size partition, 4 compartments on the left, sturdy rail with an oval profile on the right with 3 anti-rotation sliding hooks.

Compartments

2 x 300

2 x 400

2 x 300

2 x 400

Locker width

600

800

600

800

Order no.

080610-20

080610-22

080110-00

080110-02

Price

#### With base

Locker height: 1,950  
Locker depth: 500  
Base height: 100

Variant

##### Laundry locker

4 shelves on the left, storage shelf on the right with sturdy changing room rail with an oval profile and 3 anti-rotation sliding hooks

##### Cleaning supply locker

Reduced-size partition, 4 compartments on the left, sturdy rail with an oval profile on the right with 3 anti-rotation sliding hooks.

Compartments

2 x 300

2 x 400

2 x 300

2 x 400

Locker width

600

800

600

800

Order no.

080620-20

080620-22

080120-00

080120-02

Price

→ Body and door color

Color concept → p. 48



Order no. 080000-20B



Order no. 080002-22B

Doors with a turning bolt latch for padlock, shelves not adjustable.



Variant	<b>Laundry locker</b> With individually lockable doors (both hinged on the right) per compartment with 4 shelves		<b>Laundry locker</b> With doors closing in the middle (same lock) per compartment with 4 shelves	
Compartments	2 x 300	2 x 400	2 x 300	2 x 400
Locker width	600	800	600	800
Order no.	080000-20B	080000-22B	080002-20B	080002-22B
Price				

Variant	<b>Laundry locker</b> With individually lockable doors (both hinged on the right) per compartment with 4 shelves		<b>Laundry locker</b> With doors closing in the middle (same lock) per compartment with 4 shelves	
Compartments	2 x 300	2 x 400	2 x 300	2 x 400
Locker width	600	800	600	800
Order no.	080010-20B	080010-22B	080012-20B	080012-22B
Price				

Variant	<b>Laundry locker</b> With individually lockable doors (both hinged on the right) per compartment with 4 shelves		<b>Laundry locker</b> With doors closing in the middle (same lock) per compartment with 4 shelves	
Compartments	2 x 300	2 x 400	2 x 300	2 x 400
Locker width	600	800	600	800
Order no.	080020-20B	080020-22B	080022-20B	080022-22B
Price				

**+** Accessories (optional)

Selection → p. 94



# Classic PLUS

## Double-tier lockers.

Lockers, double-tier, 2 compartments on top of one another, per compartment: 1 door, sturdy wardrobe rail with an oval profile and 3 anti-rotation sliding hooks, doors at the top and bottom with ventilation gills, stamped-in label holder and turning bolt latch for padlock. Bench slats made of beech hardwood as standard, approx. 60x25 mm profile, rounded on all sides, coated with clear varnish with natural color variations. Plastic bench slats available at no additional charge. Standard color for the bench underframe: black gray RAL 7021. Absolute body height of lockers on bench or frame: 1,700 mm.



Order no. 080300-20



Order no. 080310-20



Order no. 080320-22

### Dimensions and design

With safety turning bolt  
Clear opening dimensions per door:  
854 x 240/340 x 477 (HxWxD)

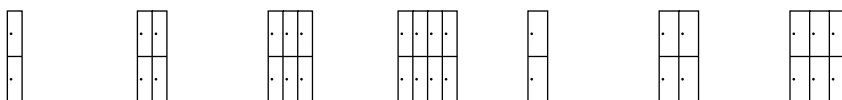

Floor-standing	Compartments	1x 300	2x 300	3x 300	4x 300	1x 400	2x 400	3x 400
Locker height: 1,850	Locker width	300	600	900	1200	400	800	1200
Locker depth: 500	Order no.	080300-10	080300-20	080300-30	080300-40	080300-12	080300-22	080300-32
	Price							

With feet	Compartments	1x 300	2x 300	3x 300	4x 300	1x 400	2x 400	3x 400
Locker height: 1,950	Locker width	300	600	900	1200	400	800	1200
Locker depth: 500	Order no.	080310-10	080310-20	080310-30	080310-40	080310-12	080310-22	080310-32
Foot height: 100	Price							

With base	Compartments	1x 300	2x 300	3x 300	4x 300	1x 400	2x 400	3x 400
Locker height: 1,950	Locker width	300	600	900	1200	400	800	1200
Locker depth: 500	Order no.	080320-10	080320-20	080320-30	080320-40	080320-12	080320-22	080320-32
Base height: 100	Price							

→ Body and door color

Color concept → p. 48



Order no. 0803507-20

Order no. 0803407-30

Order no. 0803307-32

**Variant: Hardwood bench slats**

**Dimensions and design**

Locker height: 2,120  
 Seat height: 450  
 Seat depth: 315  
 Clear opening dimensions per door:  
 779x240/340x477 (HxWxD)

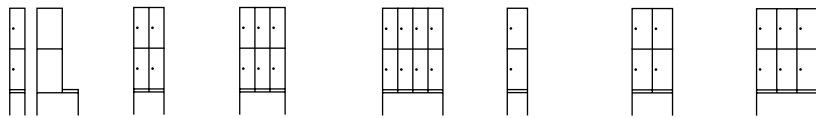

**With bench built underneath the locker**

Compartments	1x300	2x300	3x300	4x300	1x400	2x400	3x400
Locker width	300	600	900	1200	400	800	1200
Order no.	0803507-10	0803507-20	0803507-30	0803507-40	0803507-12	0803507-22	0803507-32

Locker depth, incl. bench: 815 Price

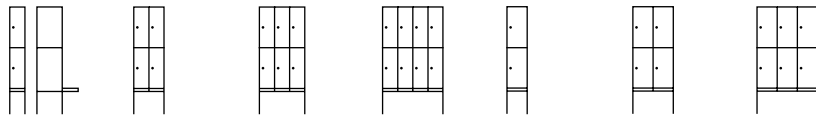

**With floating bench**

Compartments	1x300	2x300	3x300	4x300	1x400	2x400	3x400
Locker width	300	600	900	1200	400	800	1200
Order no.	0803407-10	0803407-20	0803407-30	0803407-40	0803407-12	0803407-22	0803407-32

Locker depth, incl. bench: 815

Price

⚠ Wall mounting required!

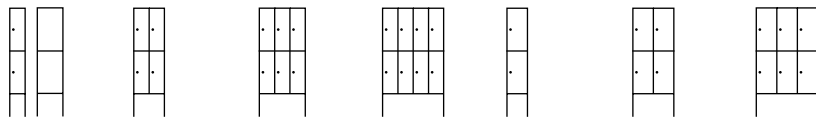

**Flush with frame underneath**

Compartments	1x300	2x300	3x300	4x300	1x400	2x400	3x400
Locker width	300	600	900	1200	400	800	1200
Order no.	0803307-10	0803307-20	0803307-30	0803307-40	0803307-12	0803307-22	0803307-32

Locker height: 2,120

Frame height: 420

Locker depth, incl. frame: 500

Price

**Optional**

Clear height above shoe rack: 225

⊕ Order no. of shoe rack	+ 08050-70110	+ 08050-70120	+ 08050-70130	+ 08050-70140	+ 08050-70112	+ 08050-70122	+ 08050-70132
⊕ Additional charge for shoe rack							

⊕ **Accessories (optional)**

Selection → p. 94



Order no. 0803507-20  
& 08520-7035



Order no. 0803407-30  
& 08530-7021



Order no. 0803407-32  
& 08532-9016

**Variant: Bench slats made of plastic**

**Dimensions and design**

Locker height: 2,120  
Seat height: 450  
Seat depth: 315  
Clear opening dimensions per door:  
779x240/340x477 (HxWxD)

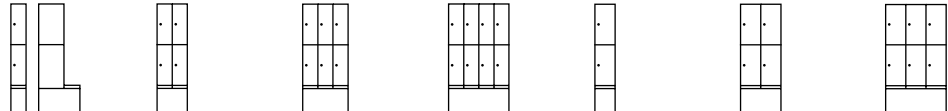

**With bench built underneath**

Locker depth incl. bench: 815

Compartment	1x300	2x300	3x300	4x300	1x400	2x400	3x400
Locker width	300	600	900	1200	400	800	1200
Order no.	0803507-10 + 08510	0803507-20 + 08520	0803507-30 + 08530	0803507-40 + 08540	0803507-12 + 08512	0803507-22 + 08522	0803507-32 + 08532
Color no. for light gray	-7035						
Color no. for white	-9016						
Color no. for black gray	-7021						
Price							

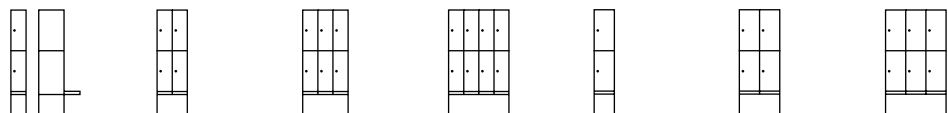

**With floating bench**

Locker depth incl. bench: 815

Compartment	1x300	2x300	3x300	4x300	1x400	2x400	3x400
Locker width	300	600	900	1200	400	800	1200
Order no.	0803407-10 + 08510	0803407-20 + 08520	0803407-30 + 08530	0803407-40 + 08540	0803407-12 + 08512	0803407-22 + 08522	0803407-32 + 08532
Color no. for light gray	-7035						
Color no. for white	-9016						
Color no. for black gray	-7021						
Price							

⚠ Wall mounting required!

**Optional**

Order no. of shoe rack	+ 08050-70110	+ 08050-70120	+ 08050-70130	+ 08050-70140	+ 08050-70112	+ 08050-70122	+ 08050-70132
Clear height above shoe rack: 225	+ Add. charge f. shoe rack						

→ **Body and door color**  
Color concept → p. 48

+ **Accessories (optional)**  
Selection → p. 94

⚠ All dimensions in mm, and all prices in Euros  
Frames also available in RAL 7035 or RAL 9016





Company

Color concept

Changing room & wardrobe

Workshop & factory

Office & archive

# Classic PLUS

## Assembled box lockers.

Doors are single-walled, smooth, without ventilation gills and without label holders (if required, please order additional plastic label holders).

400 mm compartment width also suitable for motorcycle helmets. Each door features cylinder lock and 2 keys. The bottoms of the boxes are generally finished in the body color. For publicly accessible boxes, we recommend door opening limiters.



Other locking systems → p. 160



Order no. 080000-203



Order no. 080010-223

### Variant: 3 box tiers

#### Dimensions and design

With cylinder lock and 2 keys  
Clear opening dimensions per box:  
562 x 240/340 x 477 (H x W x D)

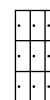
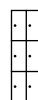

#### Floor-standing

Locker height: 1,850  
Locker depth: 500

Compartments	1x 300	2x 300	3x 300
Boxes	3	6	9
Locker width	300	600	900
Order no.	080000-103	080000-203	080000-303
Price			

#### With feet

Locker height: 1,950  
Locker depth: 500  
Foot height: 100

Compartments	1x 300	2x 300	3x 300
Boxes	3	6	9
Locker width	300	600	900
Order no.	080010-103	080010-203	080010-303
Price			

#### With base

Locker height: 1,950  
Locker depth: 500  
Base height: 100

Compartments	1x 300	2x 300	3x 300
Boxes	3	6	9
Locker width	300	600	900
Order no.	080020-103	080020-203	080020-303
Price			

#### → Body and door color

Color concept → p. 48



Order no. 080020-203



Order no. 080020-323



Compartments	4 x 300	1 x 400	2 x 400	3 x 400
Boxes	12	3	6	9
Locker width	1200	400	800	1200
Order no.	080000-403	080000-123	080000-223	080000-323
Price				

Compartments	4 x 300	1 x 400	2 x 400	3 x 400
Boxes	12	3	6	9
Locker width	1200	400	800	1200
Order no.	080010-403	080010-123	080010-223	080010-323
Price				

Compartments	4 x 300	1 x 400	2 x 400	3 x 400
Boxes	12	3	6	9
Locker width	1200	400	800	1200
Order no.	080020-403	080020-123	080020-223	080020-323
Price				

**+** Accessories (optional)

Selection → p. 94



# Classic PLUS

## Assembled box lockers.

Doors are single-walled, smooth, without ventilation gills and without label holders (if required, please order additional plastic label holders).

400 mm compartment width also suitable for motorcycle helmets. Each door features cylinder lock and 2 keys. The bottoms of the boxes are generally finished in the body color. For publicly accessible boxes, we recommend door opening limiters.



Order no. 080000-204



Order no. 080010-224

### Variant: 4 box tiers

#### Dimensions and design

With cylinder lock and 2 keys  
Clear opening dimensions per box:  
415x240/340x477 (HxWxD)



#### Floor-standing

Locker height: 1,850  
Locker depth: 500

Compartments	1x 300	2x 300	3x 300
Boxes	4	8	12
Locker width	300	600	900
Order no.	080000-104	080000-204	080000-304
Price			

#### With feet

Locker height: 1,950  
Locker depth: 500  
Foot height: 100

Compartments	1x 300	2x 300	3x 300
Boxes	4	8	12
Locker width	300	600	900
Order no.	080010-104	080010-204	080010-304
Price			

#### With base

Locker height: 1,950  
Locker depth: 500  
Base height: 100

Compartments	1x 300	2x 300	3x 300
Boxes	4	8	12
Locker width	300	600	900
Order no.	080020-104	080020-204	080020-304
Price			

#### → Body and door color

Color concept → p. 48



Order no. 080020-204



Order no. 080020-324



Compartments	4 x 300	1 x 400	2 x 400	3 x 400
Boxes	16	4	8	12
Locker width	1200	400	800	1200
Order no.	080000-404	080000-124	080000-224	080000-324
Price				

Compartments	4 x 300	1 x 400	2 x 400	3 x 400
Boxes	16	4	8	12
Locker width	1200	400	800	1200
Order no.	080010-404	080010-124	080010-224	080010-324
Price				

Compartments	4 x 300	1 x 400	2 x 400	3 x 400
Boxes	16	4	8	12
Locker width	1200	400	800	1200
Order no.	080020-404	080020-124	080020-224	080020-324
Price				

**+ Accessories (optional)**

Selection → p. 94

# Classic PLUS

## Assembled box lockers.

Doors are single-walled, smooth, without ventilation gills and without label holders (if required, please order additional plastic label holders).

400 mm compartment width also suitable for motorcycle helmets. Each door features cylinder lock and 2 keys. The bottoms of the boxes are generally finished in the body color. For publicly accessible boxes, we recommend door opening limiters.



Other locking systems → p. 160



Order no. 080000-205



Order no. 080010-225

### Variant: 5 box tiers

#### Dimensions and design

With cylinder lock and 2 keys  
Clear opening dimensions per box:  
328 x 240/340 x 477 (HxWxD)



#### Floor-standing

Locker height: 1,850  
Locker depth: 500

Compartments	1x 300	2x 300	3x 300
Boxes	5	10	15
Locker width	300	600	900
Order no.	080000-105	080000-205	080000-305
Price			

#### With feet

Locker height: 1,950  
Locker depth: 500  
Foot height: 100

Compartments	1x 300	2x 300	3x 300
Boxes	5	10	15
Locker width	300	600	900
Order no.	080010-105	080010-205	080010-305
Price			

#### With base

Locker height: 1,950  
Locker depth: 500  
Base height: 100

Compartments	1x 300	2x 300	3x 300
Boxes	5	10	15
Locker width	300	600	900
Order no.	080020-105	080020-205	080020-305
Price			

#### → Body and door color

Color concept → p. 48





Order no. 080020-205



Order no. 080020-325



Compartments	4 x 300	1 x 400	2 x 400	3 x 400
Boxes	20	5	10	15
Locker width	1200	400	800	1200
Order no.	080000-405	080000-125	080000-225	080000-325
Price				

Compartments	4 x 300	1 x 400	2 x 400	3 x 400
Boxes	20	5	10	15
Locker width	1200	400	800	1200
Order no.	080010-405	080010-125	080010-225	080010-325
Price				

Compartments	4 x 300	1 x 400	2 x 400	3 x 400
Boxes	20	5	10	15
Locker width	1200	400	800	1200
Order no.	080020-405	080020-125	080020-225	080020-325
Price				

**+ Accessories (optional)**

Selection → p. 94

# Classic PLUS

## Top lockers.

The practical and space-saving solution for when more storage space is required. Doors are single-walled, smooth, without ventilation gills and without label holders (if required, please order additional plastic label holders). 400 mm compartment width also suitable for motorcycle helmets.

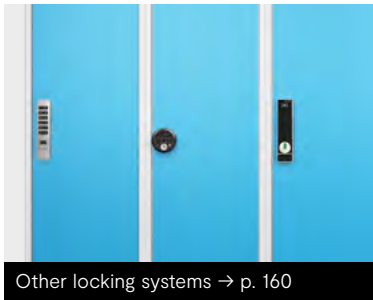

Other locking systems → p. 160



Top locker above:  
Base locker below:

Order no. 080090-20  
Order no. 080000-20



Order no. 080090-32  
Order no. 080000-32

### Dimensions and design

With turning bolt latch  
Clear opening dimensions per door:  
429 x 240/340 x 477 (H x W x D)

#### With doors hinged on the right

Locker height: 500  
Locker depth: 500

	□	□□	□□□
Compartments	1x300	2x300	3x300
Locker width	300	600	900
Order no.	080090-10	080090-20	080090-30
Price			

#### With doors closing in the middle

Locker height: 500  
Locker depth: 500

	□□	□□□□	□□
Compartments	2x300	4x300	2x400
Locker width	600	1200	800
Order no.	080092-20	080092-40	080092-22
Price			

→ **Body and door color**

Color concept → p. 48



Order no. 080092-20  
Order no. 080002-20



Order no. 080092-40  
Order no. 080002-40



Compartments	4 x 300	1x400	2x400	3x400
Locker width	1200	400	800	1200
Order no.	080090-40	080090-12	080090-22	080090-32
Price				

**+** Accessories (optional)

Selection → p. 94



# Classic PLUS

## Z lockers.

Z lockers only require the space of a double-tier locker, but offer hanging room for long items of clothing. No risk of collisions at the doors thanks to appropriate positioning of the lock.

Per compartment: 1 door, top and bottom storage shelves, sturdy changing room rail with an oval profile and 3 anti-rotation sliding hooks.

Doors above and below feature ventilation gills, punched-in label holder and turning bolt latch for padlock.

Clear opening width of the narrow area  
(comp. wid.: 300/400 mm):

Left door: 123/173 mm

Right door: 109/159 mm



Order no. 080003-204



Order no. 080013-204

### Dimensions and design

With safety turning bolt  
Clear opening dimensions per door:  
1,293 x 240/340 x 477 (H x W x D)



#### Floor-standing

Locker height: 1,850  
Locker depth: 500

Compartments	1x 300	2x 300	3x 300
Locker width	300	600	900
Order no.	080003-102	080003-204	080003-306
Price			

#### With feet

Locker height: 1,950  
Locker depth: 500  
Foot height: 100

Compartments	1x 300	2x 300	3x 300
Locker width	300	600	900
Order no.	080013-102	080013-204	080013-306
Price			

#### With base

Locker height: 1,950  
Locker depth: 500  
Base height: 100

Compartments	1x 300	2x 300	3x 300
Locker width	300	600	900
Order no.	080023-102	080023-204	080023-306
Price			

→ Body and door color

Color concept → p. 48



Order no. 080023-204



Order no. 080023-326



Compartments	4 x 300	1 x 400	2 x 400	3 x 400
Locker width	1200	400	800	1200
Order no.	080003-408	080003-122	080003-224	080003-326
Price				

Compartments	4 x 300	1 x 400	2 x 400	3 x 400
Locker width	1200	400	800	1200
Order no.	080013-408	080013-122	080013-224	080013-326
Price				

Compartments	4 x 300	1 x 400	2 x 400	3 x 400
Locker width	1200	400	800	1200
Order no.	080023-408	080023-122	080023-224	080023-326
Price				

**+** Accessories (optional)

Selection → p. 94

# Classic PLUS

## Z lockers with bench.

Bench slats for models mentioned below made of beech hardwood as standard, rounded on all sides, coated with clear varnish with natural color variations. Standard color of the bench underframes is black gray RAL 7021. Absolute body height of lockers on bench or frame: 1,700 mm.

Locker and bench are delivered separately for easy DIY assembly.

### Variant: Hardwood bench slats

#### Dimensions and design

Locker height: 2,120  
 Seat height: 450  
 Seat depth: 315  
 Clear opening dimensions per door:  
 1,218x240/340x477 (HxWxD)

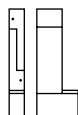

#### With bench built underneath the locker

Locker depth, incl. bench: 815

Compartments	1x300	2x300	3x300
Locker width	300	600	900
Order no.	0800537-102	0800537-204	0800537-306
Price			

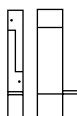

#### With floating bench

Locker depth, incl. bench: 815

Compartments	1x300	2x300	3x300
Locker width	300	600	900
Order no.	0800437-102	0800437-204	0800437-306
Price			

⚠ Wall mounting required!

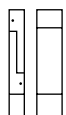

#### Flush with frame underneath

Locker depth, incl. frame: 500

Compartments	1x300	2x300	3x300
Locker width	300	600	900
Order no.	0800337-102	0800337-204	0800337-306
Price			

#### Optional

Clear height above shoe rack: 225

+ Order no. of shoe rack	+ 08050-70110	+ 08050-70120	+ 08050-70130
+ Add. charge for shoe rack			

→ Body and door color

Color concept → p. 48





Order no. 0800537-204



Order no. 0800437-306



Order no. 0800337-326 & 08050-70132

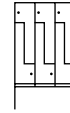
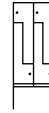
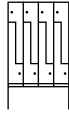

Compartments	4 x 300	1x400	2 x 400	3 x 400
Locker width	1200	400	800	1200
Order no.	0800537-408	0800537-122	0800537-224	0800537-326
Price				

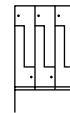
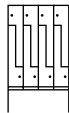

Compartments	4 x 300	1x400	2 x 400	3 x 400
Locker width	1200	400	800	1200
Order no.	0800437-408	0800437-122	0800437-224	0800437-326
Price				

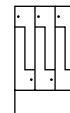
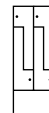
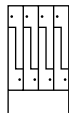

Compartments	4 x 300	1x400	2 x 400	3 x 400
Locker width	1200	400	800	1200
Order no.	0800337-408	0800337-122	0800337-224	0800337-326
Price				

+ Order no. of shoe rack	+ 08050-70140	+ 08050-70112	+ 08050-70122	+ 08050-70132
+ Add. charge for shoe rack				

+ Accessories (optional)

Selection → p. 94

# Classic PLUS

## Z lockers with bench.

Bench slats for models mentioned below made of plastic with zinc-plated steel core for optimum stability. Plastic bench slats are more hygienic and easier to clean. Standard color of the bench underframes is black gray RAL 7021. Locker and bench are delivered separately for easy DIY assembly. Absolute body height of lockers on bench or frame: 1,700 mm.



Order no. 0800537-306 & 08530-7035

### Variant: Bench slats made of plastic

#### Dimensions and design

Locker height: 2,120  
 Seat height: 450  
 Seat depth: 315  
 Clear opening dimensions per door:  
 1,218x240/340x477 (HxWxD)

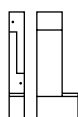

#### With bench built underneath the locker

Locker depth, incl. bench: 815

Compartments	1x300	2x300	3x300
Locker width	300	600	900
Order no.	0800537-102 + 08510	0800537-204 + 08520	0800537-306 + 08530
Color no. for light gray	-7035		
Color no. for white	-9010		
Color no. for black gray	-7021		
Price			

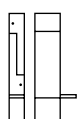

#### With floating bench

Locker depth, incl. bench: 815

⚠ Wall mounting required!

Compartments	1x300	2x300	3x300
Locker width	300	600	900
Order no.	0800437-102 + 08510	0800437-204 + 08520	0800437-306 + 08530
Color no. for light gray	-7035		
Color no. for white	-9010		
Color no. for black gray	-7021		
Price			

#### Optional

Clear height above shoe rack: 225

	+ 08050-70110	+ 08050-70120	+ 08050-70130
Order no. of shoe rack			
Add. charge f. shoe rack			

→ Body and door color

Color concept → p. 48



Order no. 0800537-306 & 08530-9010



Order no. 0800437-204 & 08520-7035



Order no. 0800537-326 & 08532-7021 & 08050-70132

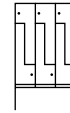
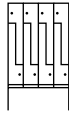

Compartments	4 x 300	1 x 400	2 x 400	3 x 400
Locker width	1200	400	800	1200
Order no.	0800537-408 + 08540	0800537-122 + 08512	0800537-224 + 08522	0800537-326 + 08532
Color no. for light gray	-7035			
Color no. for white	-9010			
Color no. for black gray	-7021			
Price				

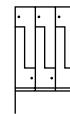
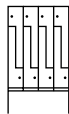

Compartments	4 x 300	1 x 400	2 x 400	3 x 400
Locker width	1200	400	800	1200
Order no.	0800437-408 + 08540	0800437-122 + 08512	0800437-224 + 08522	0800437-326 + 08532
Color no. for light gray	-7035			
Color no. for white	-9010			
Color no. for black gray	-7021			
Price				

+ Order no. of shoe rack	+ 08050-70140	+ 08050-70112	+ 08050-70122	+ 08050-70132
+ Add. charge f. shoe rack				

+ Accessories (optional)

Selection → p. 94



# Classic PLUS

## Accessories.

### Wet room version

<b>For floor-standing lockers and lockers with feet or base</b> Entire locker electrolytically zinc-plated and enamel coated				
Number of compartments	1	2	3	4
Order no.	08000-201	08000-202	08000-203	08000-204
Price				
<b>For lockers with frame/bench</b> Entire locker and frame electrolytically zinc-plated and enamel coated				
Number of compartments	1	2	3	4
Order no.	08000-211	08000-212	08000-213	08000-214
Price				



### Sloping top

220 mm high in the rear, comprised of sloping top section and side panels, can be retrofitted							
Number of compartments	1	2		3	4		
Compartment width	300	400	300	400	300	400	300
Order no.	08504-10	08504-12	08504-20	08504-22	08504-30	08504-32	08504-40
Price							



### Support for wall mounting

Rear aluminum angled rail (wall mounting holes in each locker rear panel as standard!)						
For locker width	300	400	600	800	900	1200
Order no.	08000-34030	08000-34040	08000-34060	08000-34080	08000-34090	08000-34120
Price						



### Door versions



	<b>Smooth doors</b> No ventilation gills, no stamped-in label holder, additional charge per door		<b>Doors with round holes</b> Hole pattern with 8 mm round holes as per DIN 4547, no stamped-in label holder, additional charge per door	
	Single-tier doors	Double-tier doors	Single-tier doors	Double-tier doors
Order no.	08001-303	08001-303D	08001-308	08001-308D
Price				

## Door designs



	<b>Doors with square holes</b> Hole pattern with 23 mm square holes, for looking into the locker, no stamped-in label holder		<b>Label holder</b> Made of plastic, self-adhesive	<b>Door opening limiter</b> Made of steel cable, for 90° opening angle	
	Single-tier doors	Double-tier doors	Incl. label	Per door	
Order no.	-	-	08500-15	08505-02	
Price	Project-specific on request				

## Additional equipment



	<b>Glass mirror, small</b> With tape strips, for attachment by customer	<b>Metal mirror, large</b> Polished, with tape strips, for attachment by customer	<b>Inserts for label holder</b> 1x DIN A4 sheet (27 pc.), e.g. for printing	<b>Towel hanger</b> Metal, for attachment on the door inside, only for right-hand doors	
	H 110 x B 90	H 200 x B 115	H 30 x B 60	Comp. wid. 300	Comp. wid. 400
Order no.	00018-00	00019-00	08501-071	04900-770	04900-772
Price					

## Additional equipment



	<b>Partition below the storage shelf</b> Made of translucent plastic, can be retrofitted	<b>Standard hanger</b> Hardwood, painted black	<b>Drying hanger</b> Made of plastic, black, no pant clips	<b>Drying hanger</b> Made of plastic, black, with pant clips	
	H 1,210 x D 300	With special mounting	With special mounting	With special mounting	
Order no.	04900-705	08000-061	08078-715	08078-716	
Price					

# Classic PLUS

## Accessories.

### Additional equipment

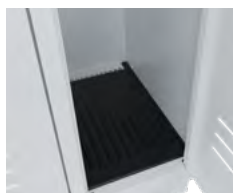

**Plastic shoe tray**  
With spacers for maintaining rear compartment ventilation

**Flush-mounted base**  
Otherwise recessed at the front as standard

**Level adjustment**  
For floor-standing lockers

**Level adjustment**  
For lockers with feet or base

Comp. wid. 300    Comp. wid. 400

Per locker

Per locker

Per locker

Order no.

08000-7072

08000-7073

08000-8020

08000-261

08000-26

Price

### Shoe shelf



Additional lower shelf or cover in compartment.  
**Permanently mounted, cannot be retrofitted**

Additional lower shelf or cover in compartment.  
**With grid bars for subsequent installation**

Installation height

250

300

Adjustable using grid bar: 200, 250, 300 or 350

For compartment width

300

400

300

400

300

400

Order no.

08000-80250

08002-80250

-

08000-80

08002-80

Price per compartment

Project-specific on request

### Double sliding hooks



Spare part, 1 PU = 10 pieces

Order no.

08500-0120

Price



## Number plates

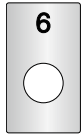

	<b>Number plate (for cylinder locks only)</b> In lock area, self-adhesive, H 79xW 45 mm, loose for easy attachment	<b>Stainless steel number plate, small</b> Free positioning, self-adhesive, H 30xW 50 mm, loose for easy attachment
	Made of plastic	Made of stainless steel
Order no.	08502-0611	08501-0611
Price		08501-06

## Door protection with number plate

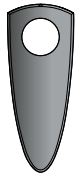

	<b>Door protection (for cylinder locks only)</b> Suitable for holding number plate model 04900-744, loose for easy attachment	<b>Number plate</b> For easy attachment above the door protection (please specify desired 3-digit number!), can only be used with door protection model 04900-742
	Made of plastic	Made of plastic
Order no.	04900-742	04900-744
Price		



## Locker connectors

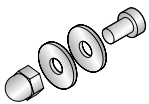

**Side locker connection** (1 set for 2 lockers), for the connection of 2 lockers to one another

Order no.	4500-715
Price	

# Sophistication, high value and presence

## The new Evolo PLUS.

This version—elevated to the next level both technically and visually—is the re-molded flagship of all our models. In environments where maximum precision and cleanliness are indispensable, it's totally in its element—laboratories, clinics, research institutes and high-tech forges, to name a few examples. Its entire appearance is smooth, hygienic and easy to clean—both outside and inside, too. It shows its astonishing technical feats effortlessly and with refined understatement. It's optimally networked and grows to meet its tasks—it loves new challenges.



Evolo PLUS designer hole pattern ventilation with Comfort label holders

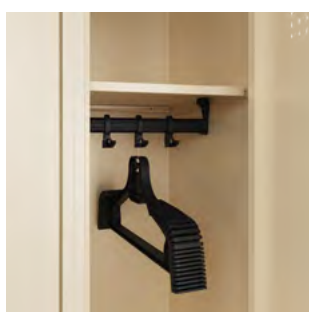

Anti-rotation and high-load-capacity double sliding hooks with special mounting, e.g. for coat hangers or retrofitted partitions



The SAFE-O-TRONIC LS 400 lock is shown here. This series enables a total of 58 different locking variants.

## Unbeatable plus points

- + Sturdy steel construction with high-quality enamel coating
- + Especially break-in-resistant design as per class C according to DIN 4547
- + 2 compartment widths, 6 different box heights
- + Special cover profile on the side in the body for easy removal of clothing, extremely easy interior cleaning and for covered cable ducts, e.g. for locking systems
- + Reinforced doors, hinged on the right, with doorstop silencer, designer ventilation hole pattern and matching Comfort label holder, as well as safety turning bolt latch for padlock (assembled box lockers with smooth doors and cylinder lock)
- + 90° door opening limiter as standard
- + Optionally available with decor doors in MDF or HPL
- + Single-tier lockers: Inside each compartment: 1 non-adjustable storage shelf, sturdy changing room rail with 3 anti-rotation double sliding hooks below
- + Double-tier lockers: Inside each box: 1 sturdy changing room rail with 3 anti-rotation double sliding hooks
- + Compartment bottoms can be swept out easily
- + Wide variety of interior fitting solutions for any requirement
- + Slim lateral edges for a homogeneous look when lined up next to one another without doubling at the locker joints
- + Additional ventilation thanks to ventilation openings in compartment bottom and top as self-ventilation concept through structurally optimized air flow behavior

### Available floor-standing, with feet, base or bench and in other versions, e.g. with built-in storage box

- + Plastic feet, base featuring increased corrosion protection, both for body RAL 7035 in light gray, otherwise in black gray
- + Standard level adjustment for floor-standing, feet or base
- + 420 mm-high bench frame made of square tubing in black gray, with 10 mm level adjustment, bench slats made of 60 x 25 mm beech, rounded on all sides, coated with clear varnish with natural color variations
- + 450 mm seat height, 315 mm seat depth
- + Bench and locker separate for easy assembly

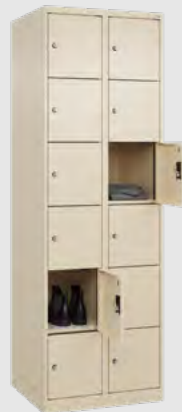
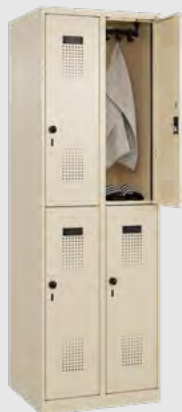



# Evolo PLUS

## Lockers with full-length door.



Order no. 049000-20

Order no. 049010-20

Order no. 049020-20  
& 08500-7940R

Order no. 049020-22 & 049122-730

### Dimensions and version

With safety turning bolt  
Clear opening dimensions per door:  
1,749 x 240/340 x 477 (H x W x D)

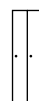
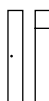

#### Floor-standing

Locker height: 1,850  
Locker depth: 500

Compartments	1x300	2x300	3x300
Locker width	300	600	900
Order no.	049000-10	049000-20	049000-30
Price			

#### With feet

Locker height: 1,950,  
Locker depth: 500  
Foot height: 100

Compartments	1x300	2x300	3x300
Locker width	300	600	900
Order no.	049010-10	049010-20	049010-30
Price			

#### With base

Locker height: 1,950  
Locker depth: 500  
Foot height: 100

Compartments	1x300	2x300	3x300
Locker width	300	600	900
Order no.	049020-10	049020-20	049020-30
Price			

#### Optional

MDF decor doors: Thickness 18  
HPL decor doors: Thickness 13

⊕ Order no. of MDF decor doors Addtl. charge for MDF decor doors	+ 049110-750	+ 049120-750	+ 049130-750
⊕ Order no. of HPL decor doors Addtl. charge for HPL decor doors	+ 049110-730	+ 049120-730	+ 049130-730

→ **Body and door color & decors**

Color and decor concept → p. 48



Compartments	4 x 300	1 x 400	2 x 400	3 x 400
Locker width	1200	400	800	1200
Order no.	049000-40	049000-12	049000-22	049000-32
Price				

Compartments	4 x 300	1 x 400	2 x 400	3 x 400
Locker width	1200	400	800	1200
Order no.	049010-40	049010-12	049010-22	049010-32
Price				

Compartments	4 x 300	1 x 400	2 x 400	3 x 400
Locker width	1200	400	800	1200
Order no.	049020-40	049020-12	049020-22	049020-32
Price				

+ Order no. of MDF decor doors	+ 049140-750	+ 049112-750	+ 049122-750	+ 049132-750
Addtl. charge for MDF decor doors				
+ Order no. of HPL decor doors	+ 049140-730	+ 049112-730	+ 049122-730	+ 049132-730
Addtl. charge for HPL decor doors				

+ Accessories (optional)

Selection → p. 154

# Evolo PLUS

## Lockers with bench.

Bench slats for models mentioned below made of beech hardwood as standard, rounded on all sides, coated with clear varnish with natural color variations. Standard color of the bench underframes is black gray RAL 7021. Absolute body height of lockers on bench or frame: 1,700 mm. Locker and bench are delivered separately for easy assembly.

### Variant: Hardwood bench slats

#### Dimensions and version

Locker height: 2,120  
 Seat height: 450  
 Seat depth: 315  
 Clear opening dimensions per door:  
 1,599x240/340x477 (HxWxD)

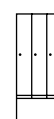
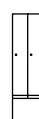
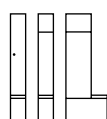

#### With bench built underneath the locker

Locker depth, incl. bench: 815

Compartments	1x300	2x300	3x300
Locker width	300	600	900
Order no.	0490507-10	0490507-20	0490507-30
Price			

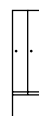
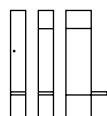

#### With floating bench

Locker depth, incl. bench: 815

Compartments	1x300	2x300	3x300
Locker width	300	600	900
Order no.	0490407-10	0490407-20	0490407-30
Price			

⚠ Wall mounting necessary!

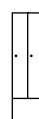
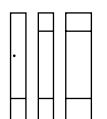

#### Flush with frame underneath

Locker depth, incl. bench: 500

Compartments	1x300	2x300	3x300
Locker width	300	600	900
Order no.	0490307-10	0490307-20	0490307-30
Price			

#### Optional

MDF decor doors: Thickness 18  
 HPL decor doors: Thickness 13  
 Clear height above shoe rack: 225

+ Order no. of MDF decor doors Addtl. charge for MDF decor doors	+ 049110-750	+ 049120-750	+ 049130-750
+ Order no. of HPL decor doors Addtl. charge for HPL decor doors	+ 049110-730	+ 049120-730	+ 049130-730
+ Order no. of shoe rack Additional charge for shoe rack	+ 08050-70110	+ 08050-70120	+ 08050-70130

#### → Body and door color & decors

Color and decor concept → p. 48





Order no. 0490507-20  
& 08500-7721R



Order no. 0490407-30  
& 08050-70130



Order no. 0490307-40  
& 00008-70R



Order no. 0490307-32  
& 049132-730 & 08050-70132

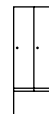
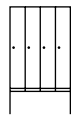

Compartments	4 x 300	1 x 400	2 x 400	3 x 400
Locker width	1200	400	800	1200
Order no.	0490507-40	0490507-12	0490507-22	0490507-32
Price				

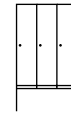
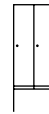
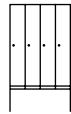

Compartments	4 x 300	1 x 400	2 x 400	3 x 400
Locker width	1200	400	800	1200
Order no.	0490407-40	0490407-12	0490407-22	0490407-32
Price				

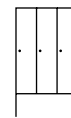
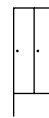
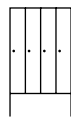

Compartments	4 x 300	1 x 400	2 x 400	3 x 400
Locker width	1200	400	800	1200
Order no.	0490307-40	0490307-12	0490307-22	0490307-32
Price				

+ Order no. of MDF decor doors	+ 049140-750	+ 049112-750	+ 049122-750	+ 049132-750
Addtl. charge for MDF decor doors				
+ Order no. of HPL decor doors	+ 049140-730	+ 049112-730	+ 049122-730	+ 049132-730
Addtl. charge for HPL decor doors				
+ Order no. of shoe rack	+ 08050-70140	+ 08050-70112	+ 08050-70122	+ 08050-70132
Additional charge for shoe rack				

+ Accessories (optional)

Selection → p. 154

# Evolo PLUS

## Lockers with bench.

Bench slats for models mentioned below made of plastic with zinc-plated steel core for optimum stability. Plastic bench slats are more hygienic and easier to clean. Standard color of the bench underframes is black gray RAL 7021. Absolute body height of lockers on bench or frame: 1,700 mm. Locker and bench are delivered separately for easy assembly.

### Variant: Bench slats made of plastic

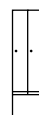
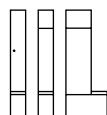

#### Dimensions and version

Locker height: 2,120  
 Seat height: 450  
 Seat depth: 315  
 Clear opening dimensions per door:  
 1,599 x 240/340 x 477 (H x W x D)



#### With bench built underneath the locker

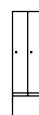
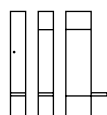

Locker depth, incl. bench: 815

Compartments	1x300	2x300	3x300
Locker width	300	600	900
Order no.	0490507-10 + 08510	0490507-20 + 08520	0490507-30 + 08530
 Color no. for light gray	-7035		
 Color no. for white	-9016		
 Color no. for black gray	-7021		
Price			



#### With floating bench



Locker depth, incl. bench: 815

Compartments	1x300	2x300	3x300
Locker width	300	600	900
Order no.	0490407-10 + 08510	0490407-20 + 08520	0490407-30 + 08530
 Color no. for light gray	-7035		
 Color no. for white	-9016		
 Color no. for black gray	-7021		
Price			

ⓘ Wall mounting necessary!

#### Optional

MDF decor doors: Thickness 18  
 HPL decor doors: Thickness 13  
 Clear height above shoe rack: 225

 Order no. of MDF decor doors	+ 049110-750	+ 049120-750	+ 049130-750
Addtl. charge for MDF decor doors			
 Order no. of HPL decor doors	+ 049110-730	+ 049120-730	+ 049130-730
Addtl. charge for HPL decor doors			
 Order no. of shoe rack	+ 08050-70110	+ 08050-70120	+ 08050-70130
Additional charge for shoe rack			

#### → Body and door color & decors

Color and decor concept → p. 48



Order no. 0490507-20  
& 08520-7035  
& 08500-7821R



Order no. 0490507-30  
& 08530-9016 & 08050-70130  
& 08500-7981R



Order no. 0490407-40  
& 08540-7021



Order no. 0490407-32 & 08532-7021  
& 049132-730 & 08050-70132

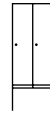
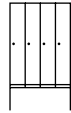

Compartments	4 x 300	1x400	2 x 400	3 x 400
Locker width	1200	400	800	1200
Order no.	0490507-40 + 08540	0490507-12 + 08512	0490507-22 + 08522	0490507-32 + 08532
Color no. for light gray	-7035			
Color no. for white	-9016			
Color no. for black gray	-7021			
Price				

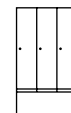
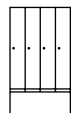

Compartments	4 x 300	1x400	2 x 400	3 x 400
Locker width	1200	400	800	1200
Order no.	0490407-40 + 08540	0490407-12 + 08512	0490407-22 + 08522	0490407-32 + 08532
Color no. for light gray	-7035			
Color no. for white	-9016			
Color no. for black gray	-7021			
Price				

+ Order no. of MDF decor doors	+ 049140-750	+ 049112-750	+ 049122-750	+ 049132-750
Adttl. charge for MDF decor doors				
+ Order no. of HPL decor doors	+ 049140-730	+ 049112-730	+ 049122-730	+ 049132-730
Adttl. charge for HPL decor doors				
+ Order no. of shoe rack	+ 08050-70140	+ 08050-70112	+ 08050-70122	+ 08050-70132
Additional charge for shoe rack				

+ Accessories (optional)

Selection → p. 154



# Evolo PLUS

## Lockers with bench.

Seat for models mentioned below with HPL top for optimal stability, seating comfort and appearance. The 13 mm-thick HPL seats are available in all HPL decors of the C+P decor concept. Standard color of the bench underframes is black gray RAL 7021. Absolute body height of lockers on bench or frame: 1,700 mm. Locker and bench are delivered separately for easy assembly.

### Variant: Seat made of HPL

#### Dimensions and version

Locker height: 2,120  
 Seat height: 438  
 Seat depth: 315  
 Clear opening dimensions per door:  
 1,599 x 240/340 x 477 (H x W x D)

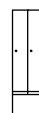
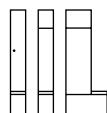

#### With bench built underneath the locker

Locker depth, incl. bench: 815

Compartment	1x300	2x300	3x300
Locker width	300	600	900
Order no.	0490507-10 + 08510-004	0490507-20 + 08520-004	0490507-30 + 08530-004
<input type="checkbox"/> Decor no. for white	-VK001		
<input type="checkbox"/> Decor no. for birch gray	-VK741		
<input checked="" type="checkbox"/> Decor no. for black	-VK008		
<input type="checkbox"/> Decor no. for silver gray	-VK002		
Price			

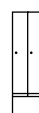
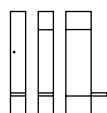

#### With floating bench

Locker depth, incl. bench: 815

ⓘ Wall mounting necessary!

Compartment	1x300	2x300	3x300
Locker width	300	600	900
Order no.	0490407-10 + 08510-004	0490407-20 + 08520-004	0490407-30 + 08530-004
<input type="checkbox"/> Decor no. for white	-VK001		
<input type="checkbox"/> Decor no. for birch gray	-VK741		
<input checked="" type="checkbox"/> Decor no. for black	-VK008		
<input type="checkbox"/> Decor no. for silver gray	-VK002		
Price			

#### Optional

MDF decor doors: Thickness 18

HPL decor doors: Thickness 13

Clear height above shoe rack: 225

<input checked="" type="checkbox"/> Order no. of MDF decor doors Addtl. charge for MDF decor doors	+ 049110-750	+ 049120-750	+ 049130-750
<input checked="" type="checkbox"/> Order no. of HPL decor doors Addtl. charge for HPL decor doors	+ 049110-730	+ 049120-730	+ 049130-730
<input checked="" type="checkbox"/> Order no. of shoe rack Additional charge for shoe rack	+ 08050-70110	+ 08050-70120	+ 08050-70130

#### → Body and door color & decors

Color and decor concept → p. 48



Order no. 0490507-20  
& 08520-004-VK001



Order no. 0490507-30  
& 08530-004-VK008  
& 08050-70130  
& 08500-767SR



Order no. 0490407-40  
& 08540-004-VK008  
& 08500-7940R



Order no. 0490407-32  
& 08532-004-VK008  
& 049132-730 & 08050-70132  
& 00008-70R

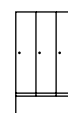
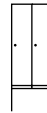
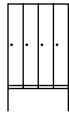

Compartments	4 x 300	1 x 400	2 x 400	3 x 400
Locker width	1200	400	800	1200
Order no.	0490507-40 + 08540-004	0490507-12 + 08512-004	0490507-22 + 08522-004	0490507-32 + 08532-004
<input type="checkbox"/> Decor no. for white	-VK001			
<input type="checkbox"/> Decor no. for birch gray	-VK741			
<input type="checkbox"/> Decor no. for black	-VK008			
<input type="checkbox"/> Decor no. for silver gray	-VK002			
Price				

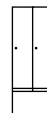
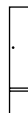
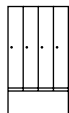

Compartments	4 x 300	1 x 400	2 x 400	3 x 400
Locker width	1200	400	800	1200
Order no.	0490407-40 + 08540-004	0490407-12 + 08512-004	0490407-22 + 08522-004	0490407-32 + 08532-004
<input type="checkbox"/> Decor no. for white	-VK001			
<input type="checkbox"/> Decor no. for birch gray	-VK741			
<input type="checkbox"/> Decor no. for black	-VK008			
<input type="checkbox"/> Decor no. for silver gray	-VK002			
Price				

+ Order no. of MDF decor doors	+ 049140-750	+ 049112-750	+ 049122-750	+ 049132-750
Addtl. charge for MDF decor doors				
+ Order no. of HPL decor doors	+ 049140-730	+ 049112-730	+ 049122-730	+ 049132-730
Addtl. charge for HPL decor doors				
+ Order no. of shoe rack	+ 08050-70140	+ 08050-70112	+ 08050-70122	+ 08050-70132
Additional charge for shoe rack				

+ Accessories (optional)

Selection → p. 154

# Evolo PLUS

## Lockers with integrated bench.

Locker in body height of 1,850 mm and doors reduced in size, on 100 mm-high base, with integrated seat thanks to bench support inserted into the body

Bench slats for models mentioned below made of beech hardwood as standard, rounded on all sides, coated with clear varnish with natural color variations. Standard color of the bench underframe is black gray RAL 7021. Locker and bench are delivered separately for easy assembly.



Order no. 049040-20 & 08500-7940R



Order no. 49040-20 & 08500-7821R



Order no. 49040-20 & 00008-70R



Order no. 49040-20

### Variant: Hardwood bench slats

#### Dimensions and version

Locker height: 1,950  
 Seat height: 450  
 Seat depth: 315  
 Clear opening dimensions per door:  
 1,599x240/340x477 (HxWxD)

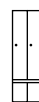
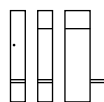

With integrated bench	Compartments	1x300	2x300	3x300
Locker depth, incl. bench: 815	Locker width	300	600	900
Base height: 100	Order no.	049040-10	049040-20	049040-30
	Price			

⚠ Wall mounting necessary!

Optional		+ 049110-750	+ 049120-750	+ 049130-750
MDF decor doors: Thickness 18	+ Order no. of MDF decor doors			
HPL decor doors: Thickness 13	Addtl. charge for MDF decor doors			
	+ Order no. of HPL decor doors	+ 049110-730	+ 049120-730	+ 049130-730
	Addtl. charge for HPL decor doors			

#### → Body and door color & decors

Color and decor concept → p. 48

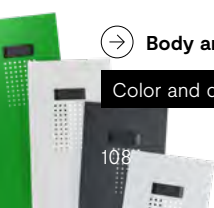

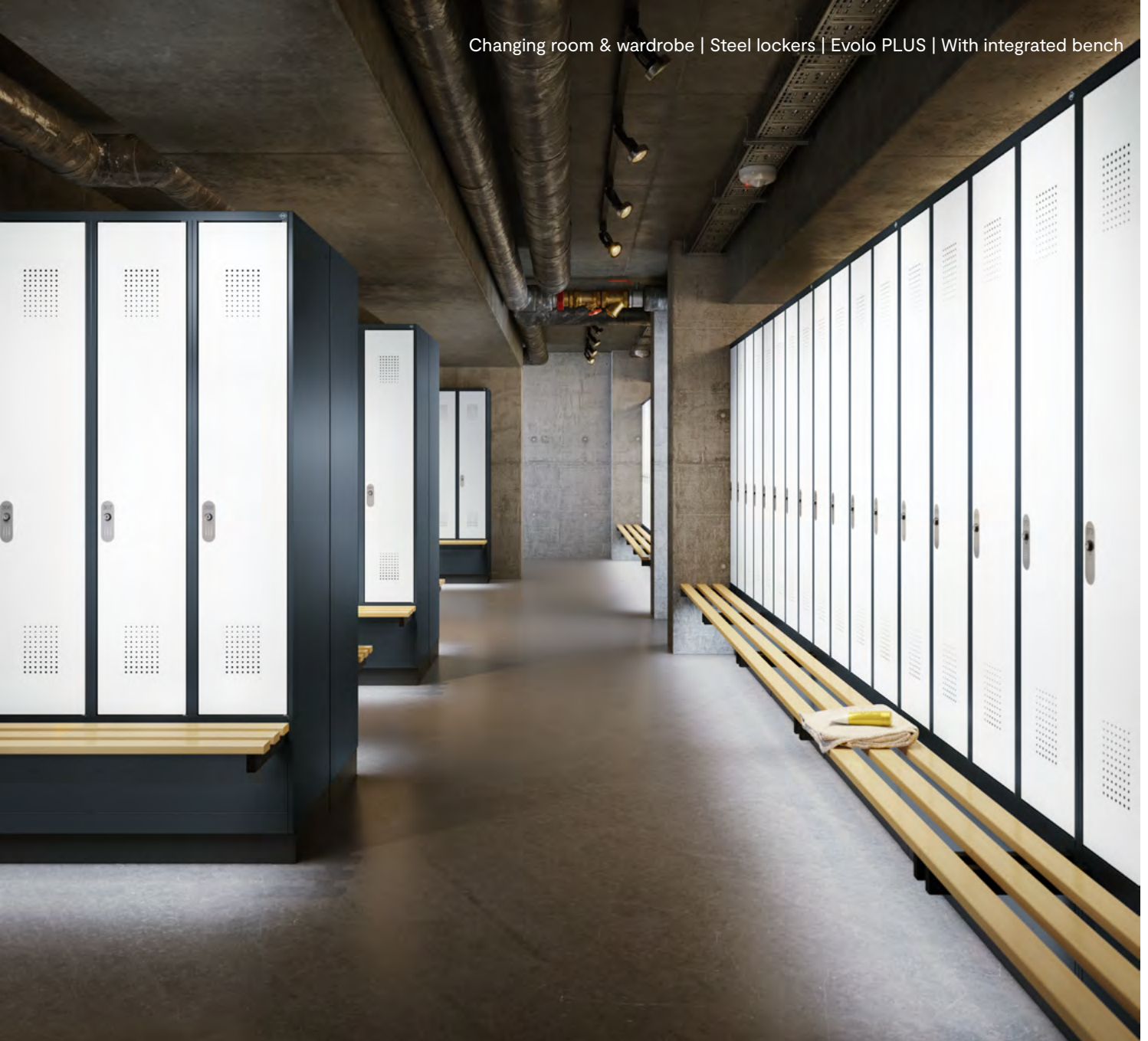

Company

Color concept

Changing room & wardrobe

Workshop & factory

Office & archive

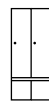
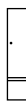
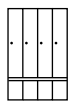

Compartments	4 x 300	1 x 400	2 x 400	3 x 400
Locker width	1200	400	800	1200
Order no.	049040-40	049040-12	049040-22	049040-32
Price				

+ Order no. of MDF decor doors	+ 049140-750	+ 049112-750	+ 049122-750	+ 049132-750
Addtl. charge for MDF decor doors				
+ Order no. of HPL decor doors	+ 049140-730	+ 049112-730	+ 049122-730	+ 049132-730
Addtl. charge for HPL decor doors				

+ Accessories (optional)

Selection → p. 154





# Evolo PLUS

## Lockers with integrated bench.

Locker in body height of 1,850 mm and doors reduced in size, on 100 mm-high base, with integrated seat thanks to bench support inserted into the body.

Seats for models mentioned below with HPL top for optimal stability, seating comfort and appearance. The 13 mm-thick HPL seats are available in all HPL decors of the C+P decor concept. Standard color of the bench underframe is black gray RAL 7021. Locker and bench are delivered separately for easy assembly.



Order no. 049040-20 & 08520-004-VK001

Order no. 049040-20 & 08520-004-VK001

Order no. 049040-20 & 08520-004-VK741

### Variant: Seat made of HPL

#### Dimensions and version

Locker height: 1,950

Seat height: 438

Seat depth: 315

Clear opening dimensions per door:

1,599 x 240/340 x 477 (H x W x D)

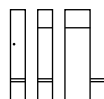

#### With integrated bench

Locker depth, incl. bench: 815

Base height: 100

ⓘ Wall mounting necessary!

	Compartment	1x300	2x300	3x300
Locker width		300	600	900
Order no.		049040-10 + 08510-004	049040-20 + 08520-004	049040-30 + 08530-004
<input type="checkbox"/> Decor no. for white		-VK001		
<input type="checkbox"/> Decor no. for birch gray		-VK741		
<input type="checkbox"/> Decor no. for black		-VK008		
<input type="checkbox"/> Decor no. for silver gray		-VK002		
Price				

#### Optional

MDF decor doors: Thickness 18

HPL decor doors: Thickness 13

⊕ Order no. of MDF decor doors	+ 049110-750	+ 049120-750	+ 049130-750
Addtl. charge for MDF decor doors			
⊕ Order no. of HPL decor doors	+ 049110-730	+ 049120-730	+ 049130-730
Addtl. charge for HPL decor doors			

→ Body and door color & decors

Color and decor concept → p. 48



Company

Color concept

Changing room & wardrobe

Workshop & factory

Office & archive



Compartments	4 x 300	1x 400	2x 400	3 x 400
Locker width	1200	400	800	1200
Order no.	049040-40 + 08540-004	049040-12 + 08512-004	049040-22 + 08522-004	049040-32 + 08532-004
<input type="checkbox"/> Decor no. for white	-VK001			
<input type="checkbox"/> Decor no. for birch gray	-VK741			
<input type="checkbox"/> Decor no. for black	-VK008			
<input type="checkbox"/> Decor no. for silver gray	-VK002			
Price				
<input type="checkbox"/> Order no. of MDF decor doors	+ 049140-750	+ 049112-750	+ 049122-750	+ 049132-750
Addtl. charge for MDF decor doors				
<input type="checkbox"/> Order no. of HPL decor doors	+ 049140-730	+ 049112-730	+ 049122-730	+ 049132-730
Addtl. charge for HPL decor doors				

Accessories (optional)

Selection → p. 154







Company

Color concept

Changing room & wardrobe

Workshop & factory

Office & archive

Lockers with built-in storage box on request  
(available as of approximately February 2024).



# Evolo PLUS

## Lockers with pairs of doors closing in the middle.

For the joint locking of two compartments for use by one person, e.g. for the separate placement of **street and work clothing**.



Order no. 049002-20    Order no. 049012-20    Order no. 049022-20    Order no. 049022-20

### Dimensions and version

With safety turning bolt  
Clear opening dimensions per door:  
1,749x240/340x477 (HxWxD)



#### Floor-standing

Locker height: 1,850  
Locker depth: 500

Compartments	2x300	4x300	2x400
For no. of persons	1	2	1
Locker width	600	1200	800
Order no.	049002-20	049002-40	049002-22
Price			

#### With feet

Locker height: 1,950  
Locker depth: 500  
Foot height: 100

Compartments	2x300	4x300	2x400
For no. of persons	1	2	1
Locker width	600	1200	800
Order no.	049012-20	049012-40	049012-22
Price			

#### With base

Locker height: 1,950  
Locker depth: 500  
Base height: 100

Compartments	2x300	4x300	2x400
For no. of persons	1	2	1
Locker width	600	1200	800
Order no.	049022-20	049022-40	049022-22
Price			

#### Optional

MDF decor doors: Thickness 18  
HPL decor doors: Thickness 13

+ Order no. of MDF decor doors	+ 049120-750	+ 049140-750	+ 049122-750
Addtl. charge for MDF decor doors			
+ Order no. of HPL decor doors	+ 049120-730	+ 049140-730	+ 049122-730
Addtl. charge for HPL decor doors			

→ **Body and door color & decors**

Color and decor concept → p. 48

+ **Accessories (optional)**

Selection → p. 154

! All dimensions in mm, and all prices in Euros





**All street/work clothing lockers also available with full-length storage shelf on request.** This results in a large box, e.g. for motorcycle helmets and personal protective equipment (PPE), which is why these lockers are also called PPE lockers.



# Evolo PLUS

## Lockers with pairs of doors closing in the middle.

Bench slats for models mentioned below made of beech hardwood as standard, rounded on all sides, coated with clear varnish with natural color variations. Standard color of the bench underframes is black gray RAL 7021. Absolute body height of lockers on bench or frame: 1,700 mm. Locker and bench are delivered separately for easy assembly.

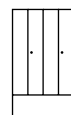
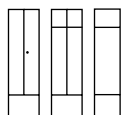

Flush with frame underneath Locker height: 2,120 Frame height: 420 Locker depth, incl. frame: 500	Compartments	2 x 300	4 x 300	2 x 400
	For no. of persons	1	2	1
	Locker width	600	1200	800
	Order no.	0490327-20	0490327-40	0490327-22
	Price			

### Variant: Hardwood bench slats

#### Dimensions and version

Locker height: 2,120  
Seat height: 450  
Seat depth: 315  
Clear opening dimensions per door:  
1,599 x 240/340 x 477 (H x W x D)

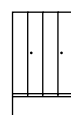
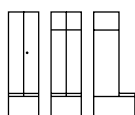

With bench built underneath the locker Locker depth, incl. bench: 815	Compartments	2 x 300	4 x 300	2 x 400
	For no. of persons	1	2	1
	Locker width	600	1200	800
	Order no.	0490527-20	0490527-40	0490527-22
	Price			

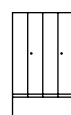
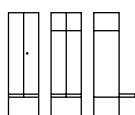

With floating bench Locker depth, incl. bench: 815  ⚠ Wall mounting necessary!	Compartments	2 x 300	4 x 300	2 x 400
	For no. of persons	1	2	1
	Locker width	600	1200	800
	Order no.	0490427-20	0490427-40	0490427-22
	Price			

Optional MDF decor doors: Thickness 18 HPL decor doors: Thickness 13 Clear height above shoe rack: 225	+ Order no. of MDF decor doors	+ 049120-750	+ 049140-750	+ 049122-750
	Addtl. charge for MDF decor doors			
	+ Order no. of HPL decor doors	+ 049120-730	+ 049140-730	+ 049122-730
	Addtl. charge for HPL decor doors			
	+ Order no. of shoe rack	+ 08050-70120	+ 08050-70140	+ 08050-70122
	Additional charge for shoe rack			

→ Body and door color & decors

Color and decor concept → p. 48

+ Accessories (optional)

Selection → p. 154

⚠ All dimensions in mm, and all prices in Euros  
Frames also available in RAL 7035 or RAL 9016

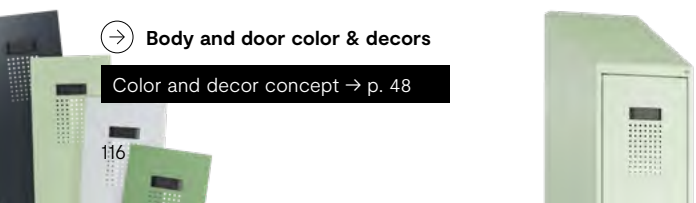





Order no. 0490527-20



Order no. 0490427-20  
& 08050-70120



Order no. 0490327-40



Order no. 0490427-40 & 08050-70140

Company

Color concept



Changing room & wardrobe

Workshop & factory

Office & archive



# Evolo PLUS

## Lockers with pairs of doors closing in the middle.

Bench slats for models mentioned below made of plastic with zinc-plated steel core for optimum stability. Plastic bench slats are more hygienic and easier to clean. Standard color of the bench underframes is black gray RAL 7021. Absolute body height of lockers on bench or frame: 1,700 mm. Locker and bench are delivered separately for easy assembly.

### Variant: Bench slats made of plastic

#### Dimensions and version

Locker height: 2,120  
 Seat height: 450  
 Seat depth: 315  
 Clear opening dimensions per door:  
 1,599x240/340x477 (HxWxD)

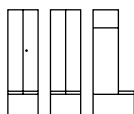

#### With bench built underneath the locker

Locker depth, incl. bench: 815

Compartment	2 x 300	4 x 300	2 x 400
Locker width	600	1200	800
For no. of persons	1	2	1
Order no.	0490527-20 + 08520	0490527-40 + 08540	0490527-22 + 08522
Color no. for light gray	-7035		
Color no. for white	-9016		
Color no. for black gray	-7021		
Price			

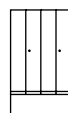
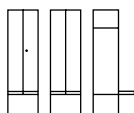

#### With floating bench

Locker depth, incl. bench: 815

! Wall mounting necessary!

Compartment	2 x 300	4 x 300	2 x 400
Locker width	600	1200	800
For no. of persons	1	2	1
Order no.	0490427-20 + 08520	0490427-40 + 08540	0490427-22 + 08522
Color no. for light gray	-7035		
Color no. for white	-9016		
Color no. for black gray	-7021		
Price			

#### Optional

MDF decor doors: Thickness 18

HPL decor doors: Thickness 13

Clear height above shoe rack: 225

+ Order no. of MDF decor doors	+ 049120-750	+ 049140-750	+ 049122-750
Addtl. charge for MDF decor doors			
+ Order no. of HPL decor doors	+ 049120-730	+ 049140-730	+ 049122-730
Addtl. charge for HPL decor doors			
+ Order no. of shoe rack	+ 08050-70120	+ 08050-70140	+ 08050-70122
Additional charge for shoe rack			

→ Body and door color & decors

Color and decor concept → p. 48

+ Accessories (optional)

Selection → p. 154

! All dimensions in mm, and all prices in Euros  
 Frames also available in RAL 7035 or RAL 9016





Order no. 0490527-20  
& 08520-7021



Order no. 0490527-20  
& 08520-7035 & 08050-70120



Order no. 0490427-40 & 08540-7021  
& 08050-70140

Company

Color concept



Changing room & wardrobe

Workshop & factory

Office & archive

# Evolo PLUS

## With pairs of doors closing in the middle.

Seat for models mentioned below with HPL top for optimal stability, seating comfort and appearance. The 13 mm-thick HPL seats are available in all HPL decors of the C+P decor concept. Standard color of the bench underframes is black gray RAL 7021. Absolute body height of lockers on bench or frame: 1,700 mm. Locker and bench are delivered separately for easy assembly.

### Variant: Bench slats made of HPL

#### Dimensions and version

Locker height: 2,120  
 Seat height: 438  
 Seat depth: 315  
 Clear opening dimensions per door:  
 1,599x240/340x477 (HxWxD)

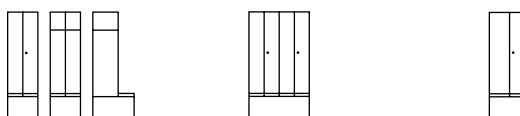

With bench built underneath the locker	Compartments	2 x 300	4 x 300	2 x 400
Locker width		600	1200	800
For no. of persons		1	2	1
Locker depth, incl. bench: 815	Order no.	0490527-20 + 08520-004	0490527-40 + 08540-004	0490527-22 + 08522-004
<input type="checkbox"/> Decor no. for white		-VK001		
<input type="checkbox"/> Decor no. for birch gray		-VK741		
<input checked="" type="checkbox"/> Decor no. for black		-VK008		
<input type="checkbox"/> Decor no. for silver gray		-VK002		
	Price			

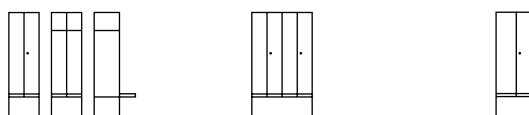

With floating bench	Compartments	2 x 300	4 x 300	2 x 400
Locker width		600	1200	800
For no. of persons		1	2	1
Locker depth, incl. bench: 815	Order no.	0490427-20 + 08520-004	0490427-40 + 08540-004	0490427-22 + 08522-004
<input type="checkbox"/> Decor no. for white		-VK001		
<input type="checkbox"/> Decor no. for birch gray		-VK741		
<input checked="" type="checkbox"/> Decor no. for black		-VK008		
<input type="checkbox"/> Decor no. for silver gray		-VK002		
	Price			

ⓘ Wall mounting necessary!

Optional				
	+ Order no. of MDF decor doors	+ 049120-750	+ 049140-750	+ 049122-750
MDF decor doors: Thickness 18	Addtl. charge for MDF decor doors			
	+ Order no. of HPL decor doors	+ 049120-730	+ 049140-730	+ 049122-730
HPL decor doors: Thickness 13	Addtl. charge for HPL decor doors			
Clear height above shoe rack: 225	+ Order no. of shoe rack	+ 08050-70120	+ 08050-70140	+ 08050-70122
	Additional charge for shoe rack			

→ **Body and door color & decors**  
 Color and decor concept → p. 48



+ **Accessories (optional)**  
 Selection → p. 154

ⓘ All dimensions in mm, and all prices in Euros  
 Frames also available in RAL 7035 or RAL 9016

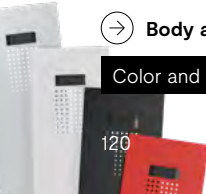





Order no. 0490527-20  
& 08520-004-VK001



Order no. 0490527-20  
& 08520-004-VK008  
& 08050-70120



Order no. 0490427-40 & 08540-004-VK001  
& 08050-70140

Company

Color concept



Changing room & wardrobe

Workshop & factory

Office & archive



# Evolo PLUS

## Lockers with pairs of doors closing in the middle with integrated bench.

Locker in body height of 1,850 mm and doors reduced in size, on 100 mm-high base, with integrated seat thanks to bench support inserted into the body.

Standard color of the bench under-frame is black gray RAL 7021. Locker and bench are delivered separately for easy assembly.



Order no. 049042-20 & 00008-70R

Order no. 049042-20 & 08500-7821R

Order no. 049042-20

### Variant: Hardwood bench slats

#### Dimensions and version

Locker height: 1,950  
 Seat height: 450  
 Seat depth: 315  
 Clear opening dimensions per door:  
 1,599 x 240/340 x 477 (H x W x D)

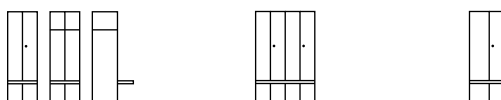

With integrated bench	Compartments	2 x 300	4 x 300	2 x 400
Locker width		600	1200	800
Locker depth, incl. bench: 815	For no. of persons	1	2	1
Base height: 100	Order no.	049042-20	049042-40	049042-22
	Price			

⚠ Wall mounting necessary!

Optional		+ 049120-750	+ 049140-750	+ 049122-750
MDF decor doors: Thickness 18	+ Order no. of MDF decor doors			
HPL decor doors: Thickness 13	Addtl. charge for MDF decor doors			
	+ Order no. of HPL decor doors	+ 049120-730	+ 049140-730	+ 049122-730
	Addtl. charge for HPL decor doors			

#### → Body and door color & decors

Color and decor concept → p. 48



Company

Color concept

Changing room & wardrobe

Workshop & factory

Office & archive

### Variant: Seat made of HPL

#### Dimensions and version

Locker height: 1,950  
 Seat height: 438  
 Seat depth: 315  
 Clear opening dimensions per door:  
 1,599 x 240/340 x 477 (H x W x D)

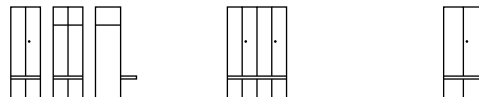

#### With integrated bench

Locker depth, incl. bench: 815  
 Base height: 100

⚠ Wall mounting necessary!

Compartments	2 x 300	4 x 300	2 x 400
Locker width	600	1200	800
For no. of persons	1	2	1
Order no.	049042-20 + 08520-004	049042-40 + 08540-004	049042-22 + 08522-004
<input type="checkbox"/> Decor no. for white	-VK001		
<input type="checkbox"/> Decor no. for birch gray	-VK741		
<input type="checkbox"/> Decor no. for black	-VK008		
<input type="checkbox"/> Decor no. for silver gray	-VK002		
Price			

#### Optional

MDF decor doors: Thickness 18  
 HPL decor doors: Thickness 13

<input type="checkbox"/> Order no. of MDF decor doors	+ 049120-750	+ 049140-750	+ 049122-750
Addtl. charge for MDF decor doors			
<input type="checkbox"/> Order no. of HPL decor doors	+ 049120-730	+ 049140-730	+ 049122-730
Addtl. charge for HPL decor doors			

#### Accessories (optional)

Selection → p. 154

# Evolo PLUS

## Multi-purpose lockers.

Doors closing in the middle with a joint turning bolt latch for padlock, shelves not adjustable.



Order no. 049600-20



Order no. 049100-00

### Dimensions and version

With safety turning bolt  
Clear opening dimensions per door:  
1,749x240/340x477 (HxWxD)

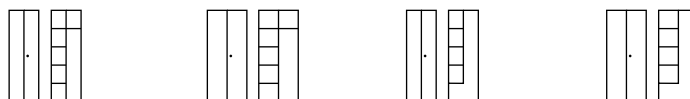

#### Floor-standing

Locker height: 1,850  
Locker depth: 500

Variant

#### Laundry locker

4 shelves on the left, storage shelf on the right with sturdy changing room rail with an oval profile and 3 anti-rotation sliding hooks

#### Cleaning supply locker

Reduced-size partition, 4 compartments on the left, sturdy rail with an oval profile on the right with 3 anti-rotation sliding hooks.

Compartments

Locker width

Order no.

Price

2 x 300

600

049600-20

2 x 400

800

049600-22

2 x 300

600

049100-00

2 x 400

800

049100-02

#### With feet

Locker height: 1,950  
Locker depth: 500  
Foot height: 100

Variant

#### Laundry locker

4 shelves on the left, storage shelf on the right with sturdy changing room rail with an oval profile and 3 anti-rotation sliding hooks

#### Cleaning supply locker

Reduced-size partition, 4 compartments on the left, sturdy rail with an oval profile on the right with 3 anti-rotation sliding hooks.

Compartments

Locker width

Order no.

Price

2 x 300

600

049610-20

2 x 400

800

049610-22

2 x 300

600

049110-00

2 x 400

800

049110-02

#### With base

Locker height: 1,950  
Locker depth: 500  
Base height: 100

Variant

#### Laundry locker

4 shelves on the left, storage shelf on the right with sturdy changing room rail with an oval profile and 3 anti-rotation sliding hooks

#### Cleaning supply locker

Reduced-size partition, 4 compartments on the left, sturdy rail with an oval profile on the right with 3 anti-rotation sliding hooks.

Compartments

Locker width

Order no.

Price

2 x 300

600

049620-20

2 x 400

800

049620-22

2 x 300

600

049120-00

2 x 400

800

049120-02

#### Optional

MDF decor doors: Thickness 18  
HPL decor doors: Thickness 13

+ Order no. of MDF decor doors  
Addtl. charge for MDF decor doors

+ Order no. of HPL decor doors  
Addtl. charge for HPL decor doors

+ 049120-750

+ 049120-730

+ 049122-750

+ 049122-730

+ 049120-750

+ 049120-730

+ 049122-750

+ 049122-730

→ Body and door color & decors

Color and decor concept → p. 48



Order no. 049000-20B



Order no. 049002-20B

Doors with a turning bolt latch for padlock, shelves not adjustable.



Variant	<b>Laundry locker</b> With individually lockable doors (both hinged on the right) per compartment with 4 shelves		<b>Laundry locker</b> With doors closing in the middle (same lock) per compartment with 4 shelves	
Compartments	2 x 300	2 x 400	2 x 300	2 x 400
Locker width	600	800	600	800
Order no.	049000-20B	049000-22B	049002-20B	049002-22B
Price				

Variant	<b>Laundry locker</b> With individually lockable doors (both hinged on the right) per compartment with 4 shelves		<b>Laundry locker</b> With doors closing in the middle (same lock) per compartment with 4 shelves	
Compartments	2 x 300	2 x 400	2 x 300	2 x 400
Locker width	600	800	600	800
Order no.	049010-20B	049010-22B	049012-20B	049012-22B
Price				

Variant	<b>Laundry locker</b> With individually lockable doors (both hinged on the right) per compartment with 4 shelves		<b>Laundry locker</b> With doors closing in the middle (same lock) per compartment with 4 shelves	
Compartments	2 x 300	2 x 400	2 x 300	2 x 400
Locker width	600	800	600	800
Order no.	049020-20B	049020-22B	049022-20B	049022-22B
Price				

+ Order no. of MDF decor doors	+ 049120-750	+ 049122-750	+ 049120-750	+ 049122-750
Addtl. charge for MDF decor doors				
+ Order no. of HPL decor doors	+ 049120-730	+ 049122-730	+ 049120-730	+ 049122-730
Addtl. charge for HPL decor doors				

+ Accessories (optional)

Selection → p. 154



# Evolo PLUS

## Double-tier lockers.

Lockers, double-tier, 2 compartments on top of one another, per compartment: 1 door, sturdy wardrobe rail with an oval profile and 3 anti-rotation sliding hooks, doors at the top and bottom with ventilation gills, stamped-in label holder and turning bolt latch for padlock. Bench slats made of beech hardwood as standard, approx. 60 x 25 mm profile, rounded on all sides, coated with clear varnish with natural color variations. Plastic bench slats available at no additional charge. Standard color for the bench underframe: Black gray RAL 7021. Absolute body height of lockers on bench or frame: 1,700 mm.



Order no. 049300-20    Order no. 049310-20 & 00008-70R    Order no. 049320-20 & 08500-7940R    Order no. 049320-22 & 049222-750

### Dimensions and version

With safety turning bolt  
Clear opening dimensions per door:  
854 x 240/340 x 477 (H x W x D)

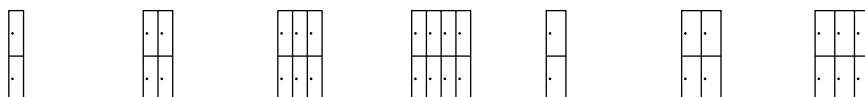

Floor-standing	Compartments	1x300	2x300	3x300	4x300	1x400	2x400	3x400
Locker height: 1,850	Locker width	300	600	900	1200	400	800	1200
Locker depth: 500	Order no.	049300-10	049300-20	049300-30	049300-40	049300-12	049300-22	049300-32
	Price							

With feet	Compartments	1x300	2x300	3x300	4x300	1x400	2x400	3x400
Locker height: 1,950	Locker width	300	600	900	1200	400	800	1200
Locker depth: 500	Order no.	049310-10	049310-20	049310-30	049310-40	049310-12	049310-22	049310-32
Foot height: 100	Price							

With base	Compartments	1x300	2x300	3x300	4x300	1x400	2x400	3x400
Locker height: 1,950	Locker width	300	600	900	1200	400	800	1200
Locker depth: 500	Order no.	049320-10	049320-20	049320-30	049320-40	049320-12	049320-22	049320-32
Base height: 100	Price							

Optional	Order no. of MDF decor doors	+ 049210-750	+ 049220-750	+ 049230-750	+ 049240-750	+ 049212-750	+ 049222-750	+ 049232-750
MDF decor doors: Thickness 18	Addtl. charge for MDF decor doors							
HPL decor doors: Thickness 13	Order no. of HPL decor doors	+ 049210-730	+ 049220-730	+ 049230-730	+ 049240-730	+ 049212-730	+ 049222-730	+ 049232-730
	Addtl. charge for HPL decor doors							

→ **Body and door color & decors**

Color and decor concept → p. 48

⊕ **Accessories (optional)**

Selection → p. 154

⚠ All dimensions in mm, and all prices in Euros



Version with multiple colors in the same locker front available on request.

Company

Color concept

Changing room & wardrobe

Workshop & factory

Office & archive

# Evolo PLUS

## Double-tier lockers.

### Variant: Hardwood bench slats

#### Dimensions and version

Locker height: 2,120  
 Seat height: 450  
 Seat depth: 315  
 Clear opening dimensions per door:  
 779x240/340x477 (HxWxD)

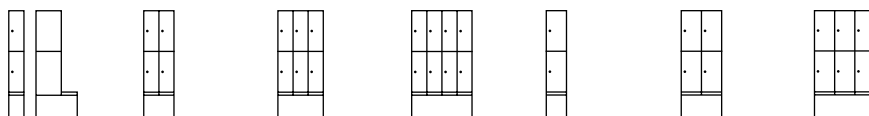

#### With bench built underneath the locker

Compartment	1x300	2x300	3x300	4x300	1x400	2x400	3x400
Locker width	300	600	900	1200	400	800	1200
Order no.	0493507-10	0493507-20	0493507-30	0493507-40	0493507-12	0493507-22	0493507-32
Price							

Locker depth, incl. bench: 815

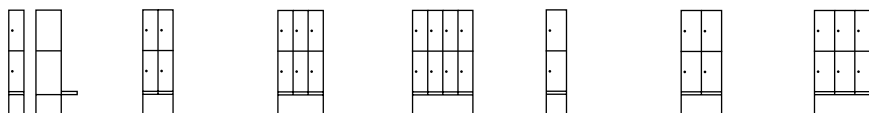

#### With floating bench

Compartment	1x300	2x300	3x300	4x300	1x400	2x400	3x400
Locker width	300	600	900	1200	400	800	1200
Order no.	0493407-10	0493407-20	0493407-30	0493407-40	0493407-12	0493407-22	0493407-32
Price							

Locker depth, incl. bench: 815

⚠ Wall mounting necessary!

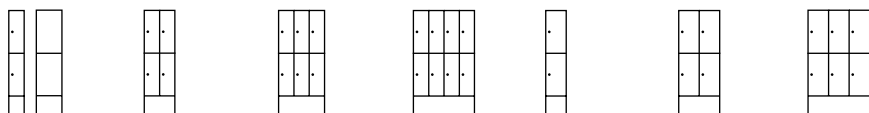

#### Flush with frame underneath

Compartment	1x300	2x300	3x300	4x300	1x400	2x400	3x400
Locker width	300	600	900	1200	400	800	1200
Order no.	0493307-10	0493307-20	0493307-30	0493307-40	0493307-12	0493307-22	0493307-32
Price							

Locker height: 2,120  
 Frame height: 420  
 Locker depth, incl. frame: 500

#### Optional

Order no. of MDF decor doors	+ 049210-750	+ 049220-750	+ 049230-750	+ 049240-750	+ 049212-750	+ 049222-750	+ 049232-750
Addtl. charge for MDF decor doors							
Order no. of HPL decor doors	+ 049210-730	+ 049220-730	+ 049230-730	+ 049240-730	+ 049212-730	+ 049222-730	+ 049232-730
Addtl. charge for HPL decor doors							
Order no. of shoe rack	+ 08050-70110	+ 08050-70120	+ 08050-70130	+ 08050-70140	+ 08050-70112	+ 08050-70122	+ 08050-70132
Additional charge for shoe rack							

MDF decor doors: Thickness 18  
 HPL decor doors: Thickness 13

Clear height above shoe rack: 225

→ Body and door color & decors

Color and decor concept → p. 48

+ Accessories (optional)

Selection → p. 154

⚠ All dimensions in mm, and all prices in Euros  
 Frames also available in RAL 7035 or RAL 9016





Order no. 0493507-20



Order no. 0493407-30  
& 08050-70130  
& 08500-7721R



Order no. 0493307-40  
& 00008-70R



Order no. 0493307-32  
& 049232-730  
& 08050-70132

Company

Color concept



Changing room & wardrobe

Workshop & factory

Office & archive



# Evolo PLUS

## Double-tier lockers.

### Variant: Bench slats made of plastic

#### Dimensions and version

Locker height: 2,120  
 Seat height: 450  
 Seat depth: 315  
 Clear opening dimensions per door:  
 779 x 240/340 x 477 (H x W x D)

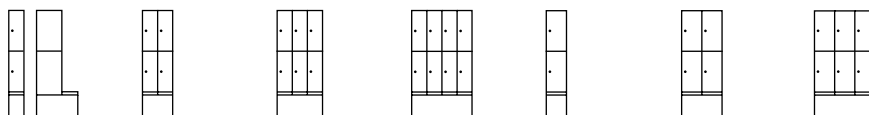

With bench built underneath the locker	Compartments	1x300	2x300	3x300	4x300	1x400	2x400	3x400
	Locker width	300	600	900	1200	400	800	1200
	Order no.	0493507-10 + 08510	0493507-20 + 08520	0493507-30 + 08530	0493507-40 + 08540	0493507-12 + 08512	0493507-22 + 08522	0493507-32 + 08532
Locker depth, incl. bench: 815	Color no. for light gray	-7035						
	Color no. for white	-9016						
	Color no. for black gray	-7021						
	Price							

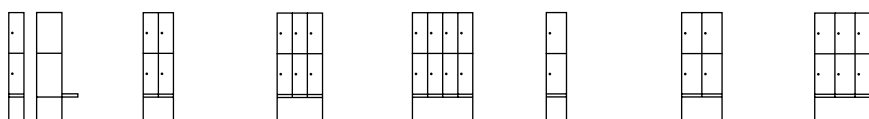

With floating bench	Compartments	1x300	2x300	3x300	4x300	1x400	2x400	3x400
	Locker width	300	600	900	1200	400	800	1200
	Order no.	0493407-10 + 08510	0493407-20 + 08520	0493407-30 + 08530	0493407-40 + 08540	0493407-12 + 08512	0493407-22 + 08522	0493407-32 + 08532
Locker depth, incl. bench: 815	Color no. for light gray	-7035						
	Color no. for white	-9016						
	Color no. for black gray	-7021						
	Price							

⚠ Wall mounting necessary!

Optional		+ 049210-750	+ 049220-750	+ 049230-750	+ 049240-750	+ 049212-750	+ 049222-750	+ 049232-750
MDF decor doors: Thickness 18	⊕ Order no. of MDF decor doors							
HPL decor doors: Thickness 13	⊕ Addtl. charge for MDF decor doors							
Clear height above shoe rack: 225	⊕ Order no. of HPL decor doors	+ 049210-730	+ 049220-730	+ 049230-730	+ 049240-730	+ 049212-730	+ 049222-730	+ 049232-730
	⊕ Addtl. charge for HPL decor doors							
	⊕ Order no. of shoe rack	+ 08050-70110	+ 08050-70120	+ 08050-70130	+ 08050-70140	+ 08050-70112	+ 08050-70122	+ 08050-70132
	⊕ Additional charge for shoe rack							

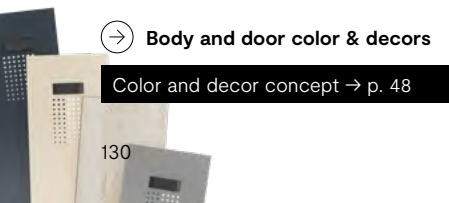

→ Body and door color & decors

Color and decor concept → p. 48



⊕ Accessories (optional)

Selection → p. 154

⚠ All dimensions in mm, and all prices in Euros  
 Frames also available in RAL 7035 or RAL 9016



Order no. 0493507-20  
& 08520-7035



Order no. 0493507-30  
& 08530-7021 & 08050-70130  
& 08500-7821R



Order no. 0493407-40  
& 08540-9016  
& 08500-767SR



Order no. 0493407-32 & 08532-7021  
& 049232-750 & 08050-70132

Company

Color concept



Changing room & wardrobe

Workshop & factory

Office & archive

# EvoLo PLUS

## Double-tier lockers.

### Variant: Seats made of HPL

#### Dimensions and version

Locker height: 2,120  
 Seat height: 438  
 Seat depth: 315  
 Clear opening dimensions per door:  
 779 x 240/340 x 477 (HxWxD)

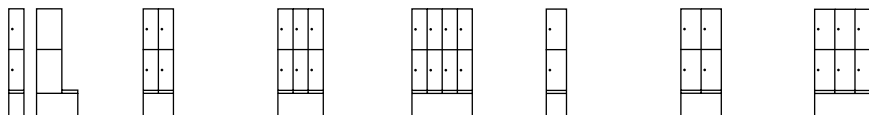

#### With bench built underneath the locker

Locker depth, incl. bench: 815

- Decor no. for white
- Decor no. for birch gray
- Decor no. for black
- Decor no. for silver gray

Compartment	1x300	2x300	3x300	4x300	1x400	2x400	3x400
Locker width	300	600	900	1200	400	800	1200
Order no.	0493507-10 + 08510-004	0493507-20 + 08520-004	0493507-30 + 08530-004	0493507-40 + 08540-004	0493507-12 + 08512-004	0493507-22 + 08522-004	0493507-32 + 08532-004
Decor no. for white	-VK001						
Decor no. for birch gray	-VK741						
Decor no. for black	-VK008						
Decor no. for silver gray	-VK002						
Price							

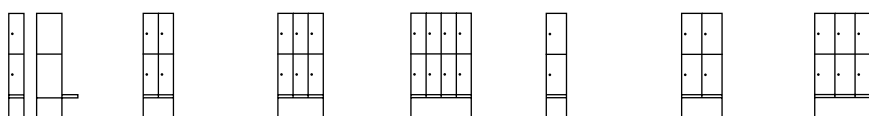

#### With floating bench

Locker depth, incl. bench: 815

- Decor no. for white
- Decor no. for birch gray
- Decor no. for black
- Decor no. for silver gray

Compartment	1x300	2x300	3x300	4x300	1x400	2x400	3x400
Locker width	300	600	900	1200	400	800	1200
Order no.	0493407-10 + 08510-004	0493407-20 + 08520-004	0493407-30 + 08530-004	0493407-40 + 08540-004	0493407-12 + 08512-004	0493407-22 + 08522-004	0493407-32 + 08532-004
Decor no. for white	-VK001						
Decor no. for birch gray	-VK741						
Decor no. for black	-VK008						
Decor no. for silver gray	-VK002						
Price							

⚠ Wall mounting necessary!

#### Optional

MDF decor doors: Thickness 18

HPL decor doors: Thickness 13

Clear height above shoe rack: 225

Order no. of MDF decor doors	+ 049210-750	+ 049220-750	+ 049230-750	+ 049240-750	+ 049212-750	+ 049222-750	+ 049232-750
Addtl. charge for MDF decor doors							
Order no. of HPL decor doors	+ 049210-730	+ 049220-730	+ 049230-730	+ 049240-730	+ 049212-730	+ 049222-730	+ 049232-730
Addtl. charge for HPL decor doors							
Order no. of shoe rack	+ 08050-70110	+ 08050-70120	+ 08050-70130	+ 08050-70140	+ 08050-70112	+ 08050-70122	+ 08050-70132
Additional charge for shoe rack							

→ Body and door color & decors

Color and decor concept → p. 48

+ Accessories (optional)

Selection → p. 154

⚠ All dimensions in mm, and all prices in Euros  
 Frames also available in RAL 7035 or RAL 9016





Order no. 0493507-20  
& 08520-004-VK741  
& 08500-7831R



Order no. 0493507-30  
& 08530-004-VK008  
& 08050-70130  
& 00008-70R



Order no. 0493407-40  
& 08540-004-VK001  
& 08500-7821R



Order no. 0493407-32  
& 08532-004-VK039  
& 049232-730  
& 08050-70132



Company

Color concept

Changing room & wardrobe

Workshop & factory

Office & archive

# Evolo PLUS

## Assembled box lockers.

Doors are single-walled, smooth, without ventilation hole pattern and without label holders (if required, please order additional plastic label holders).

400 mm compartment width also suitable for motorcycle helmets. Each door features cylinder lock and 2 keys. The bottoms of the boxes are generally finished in the body color.



Other locking systems → p. 159



Order no. 049000-203



Order no. 049010-223 & 08500-7821R

### Variant: 3 box tiers

#### Dimensions and version

With cylinder lock and 2 keys  
Clear opening dimensions per box:  
562x240/340x477 (HxWxD)

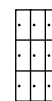
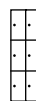

Floor-standing	Compartments	1x300	2x300	3x300
Locker height: 1,850	Boxes	3	6	9
Locker depth: 500	Locker width	300	600	900
	Order no.	049000-103	049000-203	049000-303
	Price			

With feet	Compartments	1x300	2x300	3x300
Locker height: 1,950	Boxes	3	6	9
Locker depth: 500	Locker width	300	600	900
Foot height: 100	Order no.	049010-103	049010-203	049010-303
	Price			

With base	Compartments	1x300	2x300	3x300
Locker height: 1,950	Boxes	3	6	9
Locker depth: 500	Locker width	300	600	900
Base height: 100	Order no.	049020-103	049020-203	049020-303
	Price			

Optional	Order no. of HPL decor doors	+ 049310-730	+ 049320-730	+ 049330-730
HPL decor doors: Thickness 13	Addtl. charge for HPL decor doors			

#### → Body and door color & decors

Color and decor concept → p. 48



Order no. 049020-203



Order no. 049020-323 & 049332-730



Compartments	4 x 300	1 x 400	2 x 400	3 x 400
Boxes	12	3	6	9
Locker width	1200	400	800	1200
Order no.	049000-403	049000-123	049000-223	049000-323
Price				

Compartments	4 x 300	1 x 400	2 x 400	3 x 400
Boxes	12	3	6	9
Locker width	1200	400	800	1200
Order no.	049010-403	049010-123	049010-223	049010-323
Price				

Compartments	4 x 300	1 x 400	2 x 400	3 x 400
Boxes	12	3	6	9
Locker width	1200	400	800	1200
Order no.	049020-403	049020-123	049020-223	049020-323
Price				

+ Order no. of HPL decor doors	+ 049340-730	+ 049312-730	+ 049322-730	+ 049332-730
Addtl. charge for HPL decor doors				

+ Accessories (optional)

Selection → p. 154

# Evolo PLUS

## Assembled box lockers.

Doors are single-walled, smooth, without ventilation hole pattern and without label holders (if required, please order additional plastic label holders).

400 mm compartment width also suitable for motorcycle helmets. Each door features cylinder lock and 2 keys. The bottoms of the boxes are generally finished in the body color.



Other locking systems → p. 159



Order no. 049000-204



Order no. 049010-224 & 08500-7940R

### Variant: 4 box tiers

#### Dimensions and version

With cylinder lock and 2 keys  
Clear opening dimensions per box:  
415x240/340x477 (HxWxD)



Floor-standing	Compartments	1x300	2x300	3x300
Locker height: 1,850	Boxes	4	8	12
Locker depth: 500	Locker width	300	600	900
	Order no.	049000-104	049000-204	049000-304
	Price			

With feet	Compartments	1x300	2x300	3x300
Locker height: 1,950	Boxes	4	8	12
Locker depth: 500	Locker width	300	600	900
Foot height: 100	Order no.	049010-104	049010-204	049010-304
	Price			

With base	Compartments	1x300	2x300	3x300
Locker height: 1,950	Boxes	4	8	12
Locker depth: 500	Locker width	300	600	900
Base height: 100	Order no.	049020-104	049020-204	049020-304
	Price			

Optional		+ 049410-730	+ 049420-730	+ 049430-730
HPL decor doors: Thickness 13	Order no. of HPL decor doors Addtl. charge for HPL decor doors			

#### → Body and door color & decors

Color and decor concept → p. 48





Order no. 049020-204



Order no. 049020-324 & 049432-730



Compartments	4 x 300	1 x 400	2 x 400	3 x 400
Boxes	16	4	8	12
Locker width	1200	400	800	1200
Order no.	049000-404	049000-124	049000-224	049000-324
Price				

Compartments	4 x 300	1 x 400	2 x 400	3 x 400
Boxes	16	4	8	12
Locker width	1200	400	800	1200
Order no.	049010-404	049010-124	049010-224	049010-324
Price				

Compartments	4 x 300	1 x 400	2 x 400	3 x 400
Boxes	16	4	8	12
Locker width	1200	400	800	1200
Order no.	049020-404	049020-124	049020-224	049020-324
Price				

⊕ Order no. of HPL decor doors	+ 049440-730	+ 049412-730	+ 049422-730	+ 049432-730
Addtl. charge for HPL decor doors				

⊕ **Accessories (optional)**

Selection → p. 154







Company

Color concept

Changing room & wardrobe

Workshop & factory

Office & archive

# Evolo PLUS

## Assembled box lockers.

Doors are single-walled, smooth, without ventilation hole pattern and without label holders (if required, please order additional plastic label holders).

400 mm compartment width also suitable for motorcycle helmets. Each door features cylinder lock and 2 keys. The bottoms of the boxes are generally finished in the body color.



Other locking systems → p. 159



Order no. 049000-205 & 08500-7732R



Order no. 049010-225

### Variant: 5 box tiers

#### Dimensions and version

With cylinder lock and 2 keys  
Clear opening dimensions per box:  
328 x 240/340 x 477 (HxWxD)

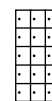
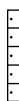

Floor-standing	Compartments	1x300	2x300	3x300
Locker height: 1,850	Boxes	5	10	15
Locker depth: 500	Locker width	300	600	900
	Order no.	049000-105	049000-205	049000-305
	Price			

With feet	Compartments	1x300	2x300	3x300
Locker height: 1,950	Boxes	5	10	15
Locker depth: 500	Locker width	300	600	900
Foot height: 100	Order no.	049010-105	049010-205	049010-305
	Price			

With base	Compartments	1x300	2x300	3x300
Locker height: 1,950	Boxes	5	10	15
Locker depth: 500	Locker width	300	600	900
Base height: 100	Order no.	049020-105	049020-205	049020-305
	Price			

Optional	Order no. of HPL decor doors	+ 049510-730	+ 049520-730	+ 049530-730
HPL decor doors: Thickness 13	Order no. of HPL decor doors			
	Addtl. charge for HPL decor doors			

#### → Body and door color & decors

Color and decor concept → p. 48





Order no. 049020-205 & 08500-7821R



Order no. 049020-325 & 049532-730

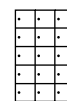

Compartments	4 x 300	1 x 400	2 x 400	3 x 400
Boxes	20	5	10	15
Locker width	1200	400	800	1200
Order no.	049000-405	049000-125	049000-225	049000-325
Price				

Compartments	4 x 300	1 x 400	2 x 400	3 x 400
Boxes	20	5	10	15
Locker width	1200	400	800	1200
Order no.	049010-405	049010-125	049010-225	049010-325
Price				

Compartments	4 x 300	1 x 400	2 x 400	3 x 400
Boxes	20	5	10	15
Locker width	1200	400	800	1200
Order no.	049020-405	049020-125	049020-225	049020-325
Price				

⊕ Order no. of HPL decor doors	+ 049540-730	+ 049512-730	+ 049522-730	+ 049532-730
Addtl. charge for HPL decor doors				

⊕ **Accessories (optional)**

Selection → p. 154

# Evolo PLUS

## Assembled box lockers.

Doors are single-walled, smooth, without ventilation hole pattern and without label holders (if required, please order additional plastic label holders).

Each door features cylinder lock and 2 keys. The bottoms of the boxes are generally finished in the body color.



Other locking systems → p. 159



Order no. 049000-206



Order no. 049010-226 & 08500-7821R

### Variant: 6 box tiers

#### Dimensions and version

With cylinder lock and 2 keys  
Clear opening dimensions per box:  
272x240/340x477 (HxWxD)

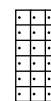
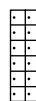
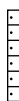

	Compartments	1x300	2x300	3x300
<b>Floor-standing</b>	Boxes	6	12	16
Locker height: 1,850	Locker width	300	600	900
Locker depth: 500	Order no.	049000-106	049000-206	049000-306
	Price			
<b>With feet</b>	Boxes	6	12	16
Locker height: 1,950	Locker width	300	600	900
Locker depth: 500	Order no.	049010-106	049010-206	049010-306
Foot height: 100	Price			
<b>With base</b>	Boxes	6	12	16
Locker height: 1,950	Locker width	300	600	900
Locker depth: 500	Order no.	049020-106	049020-206	049020-306
Base height: 100	Price			
<b>Optional</b>	Order no. of HPL decor doors	+ 049610-730	+ 049620-730	+ 049630-730
HPL decor doors: Thickness 13	Addtl. charge for HPL decor doors			

#### → Body and door color & decors

Color and decor concept → p. 48



Order no. 049020-206



Order no. 049020-326

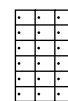
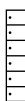
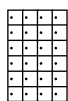

Compartments	4 x 300	1 x 400	2 x 400	3 x 400
Boxes	24	6	12	18
Locker width	1200	400	800	1200
Order no.	049000-406	049000-126	049000-226	049000-326
Price				

Compartments	4 x 300	1 x 400	2 x 400	3 x 400
Boxes	24	6	12	18
Locker width	1200	400	800	1200
Order no.	049010-406	049010-126	049010-226	049010-326
Price				

Compartments	4 x 300	1 x 400	2 x 400	3 x 400
Boxes	24	6	12	18
Locker width	1200	400	800	1200
Order no.	049020-406	049020-126	049020-226	049020-326
Price				

⊕ Order no. of HPL decor doors	+ 049640-730	+ 049612-730	+ 049622-730	+ 049632-730
Addtl. charge for HPL decor doors				

⊕ **Accessories (optional)**

Selection → p. 154



# Evolo PLUS

## Top lockers.

The practical and space-saving solution for when more storage space is required. Doors are single-walled, smooth, without ventilation hole pattern and without label holders (if required, please order additional plastic label holders). 400 mm compartment width also suitable for motorcycle helmets.



Other locking systems → p. 159



Top locker above:  
Base locker below:

Order no. 049090-20 & 00008-70R    Order no. 049090-32  
Order no. 049000-20 & 00008-70R    Order no. 049000-32

### Dimensions and version

With turning bolt latch  
Clear opening dimensions per door:  
429x240/340x477 (HxWxD)

With doors hinged on the right

Locker height: 500  
Locker depth: 500

Compartment icons	1x300	2x300	3x300
Compartment width	300	600	900
Order no.	049090-10	049090-20	049090-30
Price			

Optional

HPL decor doors: Thickness 13

Order no. of HPL decor doors	+ 0490910-730	+ 0490920-730	+ 0490930-730
Addtl. charge for HPL decor doors			

With doors closing in the middle

Locker height: 500  
Locker depth: 500

Compartment icons	2x300	4x300	2x400
Locker width	600	1200	800
Order no.	049092-20	049092-40	049092-22
Price			

Optional

HPL decor doors: Thickness 13

Order no. of HPL decor doors	+ 0490920-730	+ 0490940-730	+ 0490922-730
Addtl. charge for HPL decor doors			

→ Body and door color & decors

Color and decor concept → p. 48



Order no. 049092-20 & 08500-7721R    Order no. 049092-40  
 Order no. 049000-20 & 08500-7721R    Order no. 049002-40



Compartments	4 x 300	1 x 400	2 x 400	3 x 400
Locker width	1200	400	800	1200
Order no.	049090-40	049090-12	049090-22	049090-32
Price				

+ Order no. of HPL decor doors	+ 0490940-730	+ 0490912-730	+ 0490922-730	+ 0490932-730
Addtl. charge for HPL decor doors				

+ Accessories (optional)

Selection → p. 154

# Evolo PLUS

## Z lockers.

Z lockers only require the space of a double-tier locker, but offer hanging room for long items of clothing. Evolo PLUS models **do not have a bothersome door overhang** like conventional Z lockers. This prevents injury and enables a convenient, central lock position.

Per compartment: 2 doors closing in the middle, top and bottom storage shelves, sturdy changing room rail with an oval profile and 3 anti-rotation sliding hooks.

Doors feature label holder and turning bolt latch for padlock.

Clear opening dimensions per door  
(Comp. wid. 300/400 mm):

Height of large door: 1,293 mm

Width of left doors: 123/173 mm

Width of right doors: 109/159 mm



Order no. 049003-204



Order no. 049013-204

### Dimensions and version

With safety turning bolt



	Compartments	1x300	2x300	3x300
<b>Floor-standing</b>	Locker height: 1,850	300	600	900
	Locker depth: 500	049003-102	049003-204	049003-306
	Price			
<b>With feet</b>	Locker height: 1,950	300	600	900
	Locker depth: 500	049013-102	049013-204	049013-306
	Foot height: 100	Price		
<b>With base</b>	Locker height: 1,950	300	600	900
	Locker depth: 500	049023-102	049023-204	049023-306
	Base height: 100	Price		

Optional		+ 049210-730	+ 049220-730	+ 049230-730
HPL decor doors: Thickness 13	+ Order no. of HPL decor doors Addtl. charge for HPL decor doors			



Order no. 049023-204  
& 08500-7940R



Order no. 049023-326



Compartments	4 x 300	1 x 400	2 x 400	3 x 400
Locker width	1200	400	800	1200
Order no.	049003-408	049003-122	049003-224	049003-326
Price				

Compartments	4 x 300	1 x 400	2 x 400	3 x 400
Locker width	1200	400	800	1200
Order no.	049013-408	049013-122	049013-224	049013-326
Price				

Compartments	4 x 300	1 x 400	2 x 400	3 x 400
Locker width	1200	400	800	1200
Order no.	049023-408	049023-122	049023-224	049023-326
Price				

⊕ Order no. of HPL decor doors	+ 049240-730	+ 049212-730	+ 049222-730	+ 049232-730
Addtl. charge for HPL decor doors				

⊕ **Accessories (optional)**

Selection → p. 154



# Evolo PLUS

## Z lockers with bench.

Bench slats for models mentioned below made of beech hardwood as standard, rounded on all sides, coated with clear varnish with natural color variations. Standard color of the bench underframes is black gray RAL 7021. Absolute body height of lockers on bench or frame: 1,700 mm.

Locker and bench are delivered separately for easy assembly.

Clear opening dimensions per door (comp. wid. 300/400 mm):

Height of large door: 1,218 mm

Width of left doors: 123/173 mm

Width of right doors: 109/159 mm

### Variant: Hardwood bench slats

#### Dimensions and version

Locker height: 2,120

Seat height: 450

Seat depth: 315

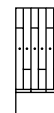
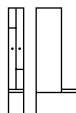

#### With bench built underneath the locker

Locker depth, incl. bench: 815

Compartments	1x300	2x300	3x300
Locker width	300	600	900
Order no.	0490537-102	0490537-204	0490537-306
Price			

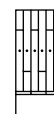

#### With floating bench

Locker depth, incl. bench: 815

Compartments	1x300	2x300	3x300
Locker width	300	600	900
Order no.	0490437-102	0490437-204	0490437-306
Price			

! Wall mounting necessary!

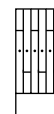
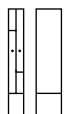

#### Flush with frame underneath

Locker height: 1,950

Locker depth: 500

Base height: 100

Compartments	1x300	2x300	3x300
Locker width	300	600	900
Order no.	0490337-102	0490337-204	0490337-306
Price			

#### Optional

HPL decor doors: Thickness 13

Clear height above shoe rack: 225

+ Order no. of HPL decor doors	+ 049210-730	+ 049220-730	+ 049230-730
Addtl. charge for HPL decor doors			
+ Order no. of shoe rack	+ 08050-70110	+ 08050-70120	+ 08050-70130
Additional charge for shoe rack			

#### → Body and door color & decors

Color and decor concept → p. 48

! Upon request, frames also available in RAL 7035 or RAL 9016





Order no. 0490537-204



Order no. 0490437-306  
& 08500-7821R



Order no. 0490337-326 & 08050-70132

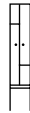
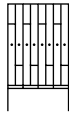

Compartments	4 x 300	1 x 400	2 x 400	3 x 400
Locker width	1200	400	800	1200
Order no.	0490537-408	0490537-122	0490537-224	0490537-326
Price				

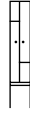
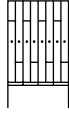

Compartments	4 x 300	1 x 400	2 x 400	3 x 400
Locker width	1200	400	800	1200
Order no.	0490437-408	0490437-122	0490437-224	0490437-326
Price				

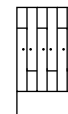
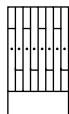

Compartments	4 x 300	1 x 400	2 x 400	3 x 400
Locker width	1200	400	800	1200
Order no.	0490337-408	0490337-122	0490337-224	0490337-326
Price				

+ Order no. of HPL decor doors	+ 049240-730	+ 049212-730	+ 049222-730	+ 049232-730
Addtl. charge for HPL decor doors				
+ Order no. of shoe rack	+ 08050-70140	+ 08050-70112	+ 08050-70122	+ 08050-70132
Additional charge for shoe rack				

+ Accessories (optional)

Selection → p. 154

# Evolo PLUS

## Z lockers with bench.

Bench slats for models mentioned below made of plastic with zinc-plated steel core for optimum stability. Plastic bench slats are more hygienic and easier to clean. Standard color of the bench underframes is black gray RAL 7021. Locker and bench are delivered separately for easy assembly. Absolute body height of lockers on bench or frame: 1,700 mm.

Clear opening dimensions per door (comp. wid. 300/400 mm):

Height of large door: 1,218 mm

Width of left doors: 123/173 mm

Width of right doors: 109/159 mm



Order no. 0490537-306  
& 08530-9016

### Variant: Bench slats made of plastic

#### Dimensions and version

Locker height: 2,120  
Seat height: 450  
Seat depth: 315



#### With bench built underneath the locker

Locker depth, incl. bench: 815

Compartment	1x300	2x300	3x300
Locker width	300	600	900
Order no.	0490537-102 + 08510	0490537-204 + 08520	0490537-306 + 08530
Color no. for light gray	-7035		
Color no. for white	-9016		
Color no. for black gray	-7021		
Price			



#### With floating bench

Locker depth, incl. bench: 815

ⓘ Wall mounting necessary!

Compartment	1x300	2x300	3x300
Locker width	300	600	900
Order no.	0490437-102 + 08510	0490437-204 + 08520	0490437-306 + 08530
Color no. for light gray	-7035		
Color no. for white	-9016		
Color no. for black gray	-7021		
Price			

#### Optional

HPL decor doors: Thickness 13

Clear height above shoe rack: 225

Order no. of HPL decor doors	+ 049210-730	+ 049220-730	+ 049230-730
Addtl. charge for HPL decor doors			
Order no. of shoe rack	+ 08050-70110	+ 08050-70120	+ 08050-70130
Additional charge for shoe rack			

#### → Body and door color & decors

Color and decor concept → p. 48

ⓘ Upon request, frames also available in RAL 7035 or RAL 9016

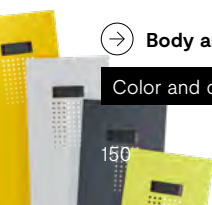



Order no. 0490537-306  
& 08530-9016



Order no. 0490437-204  
& 08520-7035 & 08500-7731R



Order no. 0490537-326 & 08532-7021  
& 08050-70132

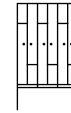
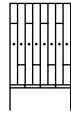

Compartments	4 x 300	1 x 400	2 x 400	3 x 400
Locker width	1200	400	800	1200
Order no.	0490537-408 + 08540	0490537-122 + 08512	0490537-224 + 08522	0490537-326 + 08532
Color no. for light gray	-7035			
Color no. for white	-9016			
Color no. for black gray	-7021			
Price				

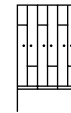
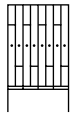

Compartments	4 x 300	1 x 400	2 x 400	3 x 400
Locker width	1200	400	800	1200
Order no.	0490437-408 + 08540	0490437-122 + 08512	0490437-224 + 08522	0490437-326 + 08532
Color no. for light gray	-7035			
Color no. for white	-9016			
Color no. for black gray	-7021			
Price				

+ Order no. of HPL decor doors	+ 049240-730	+ 049212-730	+ 049222-730	+ 049232-730
Addtl. charge for HPL decor doors				
+ Order no. of shoe rack	+ 08050-70140	+ 08050-70112	+ 08050-70122	+ 08050-70132
Additional charge for shoe rack				

+ Accessories (optional)

Selection → p. 154





# Evolo PLUS

## Z lockers with bench.

Bench slats for models mentioned below made of plastic with zinc-plated steel core for optimum stability. Plastic bench slats are more hygienic and easier to clean. Standard color of the bench underframes is black gray RAL 7021. Locker and bench are delivered separately for easy assembly. Absolute body height of lockers on bench or frame: 1,700 mm.

Clear opening dimensions per door (comp. wid. 300/400 mm):

Height of large door: 1,218 mm  
 Width of left doors: 123/173 mm  
 Width of right doors: 109/159 mm



Order no. 0490537-306  
& 08530-004-VK008

### Variant: Seat made of HPL

#### Dimensions and version

Locker height: 2,120  
 Seat height: 438  
 Seat depth: 315

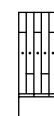

#### With bench built underneath the locker

Locker depth, incl. bench: 815

Compartments	1x300	2x300	3x300
Locker width	300	600	900
Order no.	0490537-102 + 08510-004	0490537-204 + 08520-004	0490537-306 + 08530-004
<input type="checkbox"/> Decor no. for white	-VK001		
<input type="checkbox"/> Decor no. for birch gray	-VK741		
<input checked="" type="checkbox"/> Decor no. for black	-VK008		
<input type="checkbox"/> Decor no. for silver gray	-VK002		
Price			

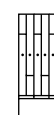
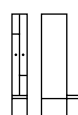

#### With floating bench

Locker depth, incl. bench: 815

⚠ Wall mounting necessary!

Compartments	1x300	2x300	3x300
Locker width	300	600	900
Order no.	0490437-102 + 08510-004	0490437-204 + 08520-004	0490437-306 + 08530-004
<input type="checkbox"/> Decor no. for white	-VK001		
<input type="checkbox"/> Decor no. for birch gray	-VK741		
<input checked="" type="checkbox"/> Decor no. for black	-VK008		
<input type="checkbox"/> Decor no. for silver gray	-VK002		
Price			

#### Optional

HPL decor doors: Thickness 13

Clear height above shoe rack: 225

<input checked="" type="checkbox"/> Order no. of HPL decor doors	+ 049210-730	+ 049220-730	+ 049230-730
Addtl. charge for HPL decor doors			
<input checked="" type="checkbox"/> Order no. of shoe rack	+ 08050-70110	+ 08050-70120	+ 08050-70130
Additional charge for shoe rack			

#### → Body and door color & decors

Color and decor concept → p. 48

⚠ Upon request, frames also available in RAL 7035 or RAL 9016



Order no. 0490537-306 & 08530-004-VK001

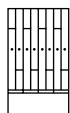

Order no. 0490437-204 & 08520-004-VK001 & 08500-797R



Order no. 0490537-326 & 08532-004-VK008 & 08050-70132

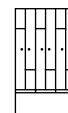

Compartments	4 x 300	1 x 400	2 x 400	3 x 400
Locker width	1200	400	800	1200
Order no.	0490537-408 + 08540-004	0490537-122 + 08512-004	0490537-224 + 08522-004	0490537-326 + 08532-004
<input type="checkbox"/> Decor no. for white	-VK001			
<input type="checkbox"/> Decor no. for birch gray	-VK741			
<input type="checkbox"/> Decor no. for black	-VK008			
<input type="checkbox"/> Decor no. for silver gray	-VK002			
Price				

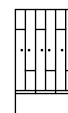
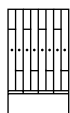

Compartments	4 x 300	1 x 400	2 x 400	3 x 400
Locker width	1200	400	800	1200
Order no.	0490437-408 + 08540-004	0490437-122 + 08512-004	0490437-224 + 08522-004	0490537-326 + 08532-004
<input type="checkbox"/> Decor no. for white	-VK001			
<input type="checkbox"/> Decor no. for birch gray	-VK741			
<input type="checkbox"/> Decor no. for black	-VK008			
<input type="checkbox"/> Decor no. for silver gray	-VK002			
Price				

<input type="checkbox"/> Order no. of HPL decor doors	+ 049240-730	+ 049212-730	+ 049222-730	+ 049232-730
Addtl. charge for HPL decor doors				
<input type="checkbox"/> Order no. of shoe rack	+ 08050-70140	+ 08050-70112	+ 08050-70122	+ 08050-70132
Additional charge for shoe rack				

**+ Accessories (optional)**

Selection → p. 154

# Evolo PLUS

## Accessories.

### Wet room design

<b>For floor-standing lockers and lockers with feet or base</b> Entire locker electrolytically zinc-plated and enamel coated				
Number of compartments	1	2	3	4
Order no.	08000-201	08000-202	08000-203	08000-204
Price				
<b>For lockers with frame/bench</b> Entire locker and frame electrolytically zinc-plated and enamel coated				
Number of compartments	1	2	3	4
Order no.	08000-211	08000-212	08000-213	08000-214
Price				



### Sloping top

220 mm high in the rear, comprised of sloping top section and side panels, can be retrofitted							
Number of compartments	1	2		3	4		
Compartment width	300	400	300	400	300	400	300
Order no.	08504-10	08504-12	08504-20	08504-22	08504-30	08504-32	08504-40
Price							



### Support for wall mounting

Rear aluminum angled rail (wall mounting holes in each locker rear panel as standard!)						
For locker width	300	400	600	800	900	1200
Order no.	08000-34030	08000-34040	08000-34060	08000-34080	08000-34090	08000-34120
Price						



### Door designs



	<b>Smooth doors</b> No ventilation gills, no stamped-in label holder, additional charge per door		<b>Doors with round holes</b> Hole pattern with 8 mm round holes as per DIN 4547, no stamped-in label holder, additional charge per door	
	Single-tier doors	Double-tier doors	Single-tier doors	Double-tier doors
Order no.	04901-303	04901-303D	04901-308	04901-308D
Price				

## Door designs

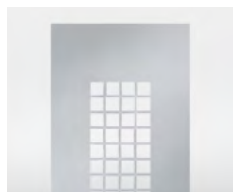

	<b>Doors with square perforations</b> Hole pattern with 23 mm square holes, for looking into the locker, no label holder	<b>Letter drop</b> With rounded corners, H 25 x W 140/240, for <b>steel doors</b>	<b>Letter drop</b> With rounded corners, H 25 x W 140/240, for <b>decor doors</b>	<b>Collection box on the door inside</b> for doors with letter drop			
		Comp. wid. 300	Comp. wid. 400	Comp. wid. 300	Comp. wid. 400	Comp. wid. 300	Comp. wid. 400
Order no.	-	04900-131	04900-132	04900-133	04900-134	04900-141	04900-142
Price	Project-specific on request						

## Additional equipment

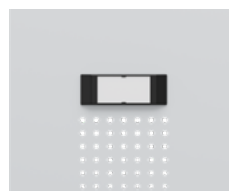

	<b>Glass mirror, small</b> With tape strips, for attachment by customer	<b>Metal mirror, large</b> Polished, with tape strips, for attachment by customer	<b>Additional inserts for label holder</b> 1x DIN A4 sheet (27 pc.), e.g. for printing	<b>Omission of label holder</b> for single- and double-tier lockers
	H 110 x B 90	H 200 x B 115	H 30 x B 60	E.g. for numbering in lock area, p. 97
Order no.	00018-00	00019-00	08501-071	04901-306
Price				

## Additional equipment



	<b>Partition below the storage shelf</b> Made of translucent plastic, can be retrofitted	<b>Standard coat hanger</b> Hardwood, painted black	<b>Drying hanger</b> Made of plastic, black, no pant clips	<b>Drying hanger</b> Made of plastic, black, with pant clips
	H 1,210 x D 300	With special mounting	With special mounting	With special mounting
Order no.	04900-705	08000-061	08078-715	08078-716
Price				



## Additional equipment



**Plastic shoe tray** With spacers for maintaining rear compartment ventilation

**Flush-mounted base** Otherwise recessed at the front as standard

**Omission of the door opening limiter**, approx. 110° door opening angle

**Evolvo label holder** Individual, plastic, self-adhesive, incl. label

Comp. wid. 300

Comp. wid. 400

Per locker

E.g. for assembled box lockers (3 or more vertical doors)

Order no.

08000-7072

08000-7073

04900-4920

04900-7061

04900-715

Price

## Shoe shelf permanently installed

Additional lower shelf or cover in compartment.  
**Permanently mounted, cannot be retrofitted**

Installation height	200		250		300		350	
	300	400	300	400	300	400	300	400
Order no.	08000-80200	08002-80200	08000-80250	08002-80250	08000-80300	08002-80300	08000-80350	08002-80350

Price per compartment



## Retrofittable shoe shelf

Additional lower shelf or cover in compartment.  
With grid bars for subsequent installation

Installation height	Adjustable using grid bar: 200, 250, 300 or 350			
For compartment width	300		400	
Order no.	08000-80		08002-80	

Price per compartment



## Additional equipment for door interior

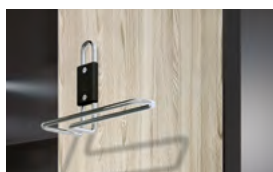

Metal	Towel hanger for right-hand doors	Towel holder	Towel and shower gel holder	Shoe and flip-flop holder
Application	Only for <b>steel fronts</b>	Only for <b>decor fronts</b>	Only for <b>decor fronts</b>	Only for <b>decor fronts</b>
For compartment width	300      400	300      400	300      400	300      400
Order no.	04900-770      04900-772	04900-7703	04900-7723	04900-7733

Price

## Double sliding hooks



Spare part, 1 PU = 10 pieces

Order no.

08500-0120

Price

## Number plates

263

Stainless steel number plate, small  
Free positioning, self-adhesive, H 30 x W 50 mm,  
loose for easy attachment

Made of stainless steel

Order no.

08501-06

Price

## Number plates

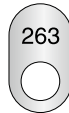
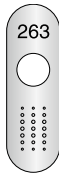

**Only suitable for cylinder locks!**

**Number plate with integrated door protection**  
H 123 x W 39 mm, in lock area, self-adhesive, loose for easy attachment

**Number plate without integrated door protection**  
H 68 x W 39 mm, in lock area, self-adhesive, loose for easy attachment

Made of plastic

Made of stainless steel

Made of plastic

Made of stainless steel

Order no.

04902-0601

04901-0601

04902-0611

04901-0611

Price



## Door protection with number plate

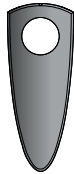

**Door protection (for cylinder locks only)**  
Suitable for holding number plate model 04900-744, loose for easy attachment

**Number plate**  
For easy attachment above the door protection (please specify desired 3-digit number!), can only be used with door protection model 04900-742

Made of plastic

Made of plastic

Order no.

04900-742

04900-744

Price



## Locker connectors

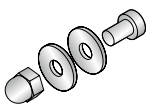

**Side locker connection** (1 set for 2 lockers), for the connection of 2 lockers to one another

Order no.

4500-715

Price

023



024



025





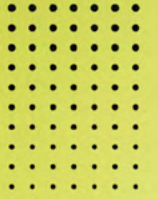

026



# Locking systems

## Which locking system for which application/task?

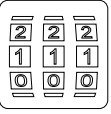
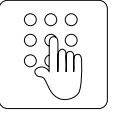
One lock fits all? That's a thing of the past. C+P locking system solutions are as versatile as the applications of today. For orientation purposes, this double page includes an overview of the most important options. We'd be happy to provide consultation for your specific project.

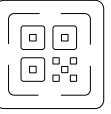
							
	Cylinder locks with key	Turning bolt for padlocks	Mechanical deposit and token-operated locks	Mechanical PIN code locks	Electronic PIN code locks	Electronic RFID locks	Digitized locking systems (SmartLockers)
Designation							
Security	★★	★★	★★	★★	★★	★★★	★★★
Convenience	★	★	★	★★	★★★	★★★	★★★
Function	★	★★	★★	★★	★★★	★★★	★★★
Lock type	Mechanical	Mechanical	Mechanical	Mechanical	Battery	Battery/Cable	Cable

Legend	★ = Good	★★ = Better	★★★ = Optimal
--------	----------	-------------	---------------

Classic PLUS	●	●	●	●	on request	-	-
Evolo PLUS	●	●	●	●	●	●	●
Cambio	●	●	●	●	●	●	-
Prefino	●	●	●	●	●	●	●
FLEX+	●	●	●	●	●	●	-
Intro	●	●	●	●	●	●	-
Resisto	●	●	●	●	●	●	-
Special solutions	●	●	●	●	●	●	-

Legend	● = Possible	- = Not possible
--------	--------------	------------------









If you have any requests— we like a good challenge



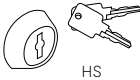
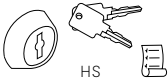

# Locking systems



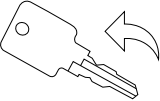
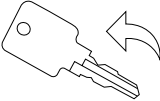
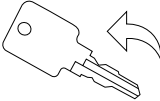
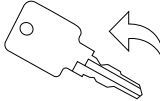

## Classic PLUS and Evolo PLUS

- + All lockers with 1 or 2 tiered compartments always feature safety turning bolt
- + All assembled box lockers (3 or more tiered boxes) always feature cylinder locks

<b>Optional features</b> Available as standard with 2 keys instead of the standard installed solutions	<b>Rotary cylinder lock</b> (*no additional charge for lockers with C+P safety turning bolt)	<b>Rotary cylinder lock</b>	<b>Rotary cylinder lock</b> For master locking function (ML)	<b>Rotary cylinder lock</b> For master locking function (ML)
				
Number of key numbers	Up to 1,000*	Up to 6,000	Up to 6,000	Up to 6,000
Master locking functions	-	-	Without security certificate	With security certificate
Order no.	00008-70R	00008-700R	00010-010R	00010-10R
Price				
<b>Same version as above, except with 4 keys</b>		-	-	We'd be happy to advise you on additional accessories for the lockers you need.
Number of key numbers	Up to 1,000	-	-	
Order no.	00008-704R	-	-	
Price		-	-	
<b>Wet room design</b> 		-	-	
Number of keys	2	-	2	2
Order no.	00008-72R	-	00010-012R	00010-12R
Price		-		
<b>Lock no. as per customer request or for simultaneous locking.</b> For combining lockers				
	For rotary cylinder lock	For rotary cylinder lock	For rotary cylinder lock	For rotary cylinder lock
For key numbers	Up to 1,000	Up to 6,000	ML without security cert.	ML with security cert.
Order no.	00008-7099R	00008-70099R	00010-01099R	00010-1099R
Price				
<b>Spare and master keys for reorder</b> For existing key numbers				
For key numbers	Up to 1,000	Up to 6,000	ML without security cert.	ML with security cert.
Order no.	00006-21	00006-00	00006-00	00010-11
<b>Spare key</b>				
Price				
Order no.	-	-	00012-00	00011-00
<b>Master key</b>				
Price	-	-		

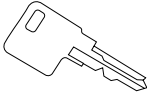
## Turning bolt locks for use with padlocks

<b>Optional features</b> Instead of the standard installed solutions	<b>Turning bolt with master key function</b>	<b>C + P safety turning bolt</b> (no additional charge for lockers with cylinder lock)	<b>Safety turning bolt KEYLESS H3</b> , matte nickel	-
				
Protection function	For master key	With over-twist protection	With over-twist protection	-
For use for	Bolt size 6 – 8 mm	Bolt size 6 – 8 mm	Bolt size 6 – 8 mm	-
Order no.	00002-010R	08500-718R	08500-719R	-
Price				-

<b>Optional accessories and padlocks for turning and safety turning bolts</b> , bolt size: approx. 6 mm.				
	Master key for turning bolt	Padlock, brass version, 2 keys	Safety lock made of brass, precision cylinder, 2 keys	BURG number CODE-lock with hardened steel shackle
Key numbers	-	Up to 300	Up to 168,000	With 4-digit combination
Order no.	00014-00	0002-10	0002-11	00002-14
Price				

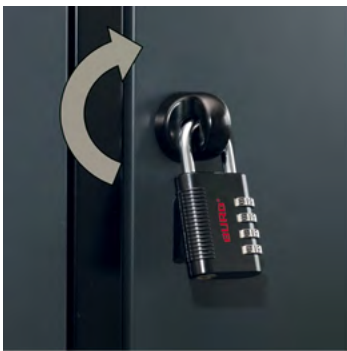

**C + P safety turning bolt**  
Turns while locked, thereby preventing break-in through over-twisting.

# Locking systems

## Classic PLUS and Evolo PLUS

Electronic PIN code locks with master code function (for Classic PLUS on request)

	<b>WF 1904</b> For master key, black	<b>EURO-LOCKS 3780</b> For master key, black	<b>EURO-LOCKS 3780</b> For master key, silver	<b>Digilock NEXT SOLA 3</b>
				
				
Number of key numbers	999.999	999.999	999.999	999.999
Color	Black	Black	Silver	Nickel
Order no.	08500-7871R	08500-764SR	08500-765SR	08500-797R
Price				
Master key				
Order no.	08500-789	08500-766	08500-766	on request
Price				

Electronic RFID locks for use of RFID cards (for Evolo PLUS **only**)

	<b>Digilock NEXT SOLA 3</b>	<b>Gantner GAT ECO.Lock 7xxx</b>	<b>SAFE-O-TRONIC ACCESS LS 300</b> Black	<b>SAFE-O-TRONIC ACCESS LS 300</b> White	<b>GANTNER GL7p RFID</b> White
					
					
RFID types	MIFARE®	MIFARE®	MIFARE®	MIFARE®	MIFARE®
Order no.	08500-798R	08500-738	08500-7930R	08500-7931R	08500-767R
Price					

Our specialist consultants stand ready to assist you in determining your needs and consulting on your projects in a professional way

## Combination and deposit locks

### GANTNER GL7p RFID & PIN White

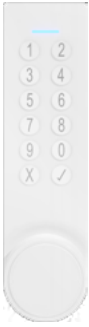

999.999

White

08500-768R

–

### OJMAR OTS BASIC



MIFARE®

08500-741

For the WF 1401 model for fixed users, the code is automatically blurred after each use but remains stored. For the WF 2112 model for changing users, the code is reset before each use and manually blurred by the user.

#### Combination lock WF 1401 For permanent users, black



With master key  
function

Number of key numbers

9.999

Color

Black

Order no.

08500-7721R

Price

#### Combination lock WF 2112 For changing users, black



With master key  
function

9.999

Black

Order no.

08500-7752R

#### Coin-operated deposit lock WF 1606



“Deposit lock light”  
with clamping device  
for deposit coin

–

Black

Order no.

08500-7821R

#### Master key WF 1401

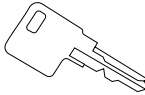

Order no.

08500-774

Price

#### Master key WF 2112

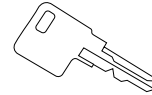

Order no.

08500-7745

#### Master key WF 1606

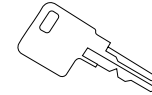

Order no.

08500-784

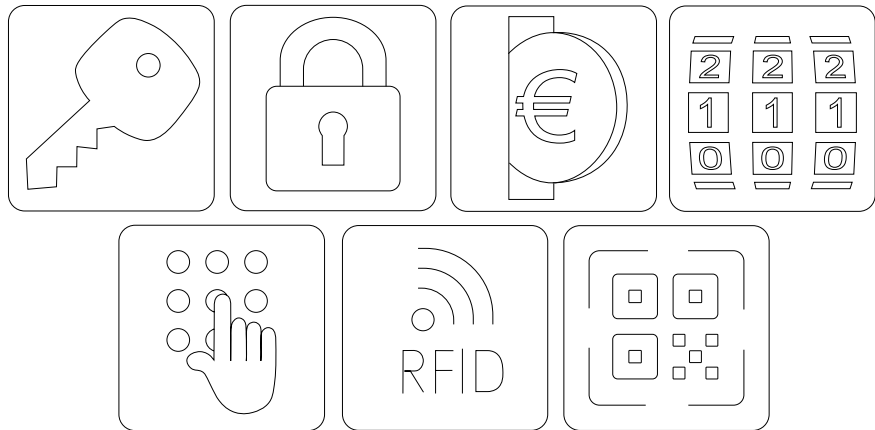

For **PIN code** and **RFID locks**, there are a variety of options and solutions available to suit all customer requirements.

Thanks to decades of experience and close cooperation with just about every locking system manufacturer, C + P’s knowledge across the entire breadth of applications is unmatched.

From simple code locks to networked security compartment systems to interactive assembled box locker solutions in the SmartLocker sector, we’re always able to offer the right solution to any requirement.

**Please contact our specialist consultants!**



# Locking systems

## Classic PLUS and Evolo PLUS

### SAFE-O-MAT locks



**Attention:**  
Key heads **cannot be retrofitted**; please order the variant you need! (see below)

**Twin-coin deposit lock**  
For use with 1 and 2 Euro coins

**Twin-coin token-operated lock**, multi-use lock for 2 Euro deposit and 1 Euro cash function

**Sign**  
For outside, indicates SAFE-O-MAT

**Number plate**  
Alternative to the note plate; please specify number

Incl. 1 user key

Incl. 1 user key

Included

Included

With standard key head

Order no.

08500-731R

08501-40R

Included

08501-430

With ball holder key head

08500-731RKH

08501-40RKH

With ball ring key head

08500-731RKR

08501-40RKR

Price

### Accessories for SAFE-O-MAT locks



**Promax replacement cylinders** for cylinder exchange after emergency opening, e.g. if key is lost

**Promax emergency opening key** for emergency opening and cylinder exchange

**Spare key** for SAFE-O-MAT lock, to be ordered additionally upon order placement

**Number set** with 50 small number plates for clipping into the key heads

Incl. 1 user key

Incl. 1 user key

Included

Please specify: 001 – 050, ...

With standard key head

Order no.

08501-4101

08511-00

08501-4102

08501-55

With ball holder key head

08501-4101KH

08501-4102KH

With ball ring key head

08501-4101KR

08501-4102KR

Price

! Additional information on SAFE-O-MAT coin-operated locks can be found on p. 219.

### Wristband sets and number tags



<b>Color numbers:</b> 51 black 52 white 53 red 55 blue 61 green 67 yellow	<b>Wristband set 1 for standard key head</b> Wristband can be passed through crosswise	<b>Wristband set 2 for ball holder key head</b> With protective pouch for holding a key parallel to wristband	<b>Key ring for ball ring key head</b> For the attachment of number plates or key rings	<b>Astralon number plate for ball ring key head</b> White, for key ring
	<b>Color: 51 black;</b> other colors no addtl. charge, change color no. at end of order no. Please specify desired numbers!	Please specify color no. and desired numbers!		Please specify numbers!
Order no.	08501-4651	08501-4651KH	08501-47	08501-48
Price				

### Coin-operated deposit lock ASSA-RUKO



	<b>Coin-operated deposit lock</b> for 1 Euro coins, with standard master key function	<b>Master key for coin-operated deposit lock</b>
	Incl. 1 user key	
Order no.	08500-745R	08511-20
Price		

### Accessories for ASSA-RUKO lock

	Replacement exchangeable cylinder	Removal key	Spare key
Order no.	08500-7450	08511-21	08511-22
Price			

# More versatile than other lockers

## Cambio lockers.

Cambio from C+P is more than just a locker!  
 These hard facts make this range so very  
 incomparable:

- + **Innovative ventilation**  
 and drying thanks to the SVL, FVL and FVLD concepts  
 (see p. 170)
- + **Optimum use of space and interior design**  
 thanks to corner, niche and end solutions
- + **Underbench solutions designed to meet your needs**  
 for adaptation to any room situation
- + **Choose from many materials and colors**  
 for every taste and every need
- + **Body, base and steel doors electrolytically  
 zinc-plated as standard**







Cambio →

Cambio from C+P features lots of space for customer-specific solutions, of which a few examples are shown on the following pages. The range of options is endless: single- and double-walled steel doors, HPL decor doors, corner lockers, electronic locking systems and so much more...

Let us know what you're looking for and send us your project-specific request! In the world of changing room and assembled box lockers, Cambio is the professional answer to just about every furnishing requirement.



# Optimal Cambio lockers.



→ The Cambio ventilation concepts

Detailed explanation → p. 170

Sophisticated and pleasant for meeting the highest standards.



130 mm-high feet, vertically adjustable from inside and outside with sleeves.



**Single- or double-walled doors with insulation:**  
Single-walled steel doors with closed side profiles for maximum stability. Double-walled sandwich construction doors with convenient body sound absorption for minimal unpleasant noise.

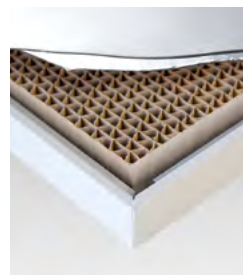

90° door opening limiter as standard design. New design with high-load, plastic-sheathed stainless steel special cable.



# 172

Lockers



# 174

Lockers, double-tier



# 176

Assembled box lockers



# 180

Z lockers  
and corner solutions

Company

Color concept

Changing room & wardrobe

Workshop & factory

Office & archive

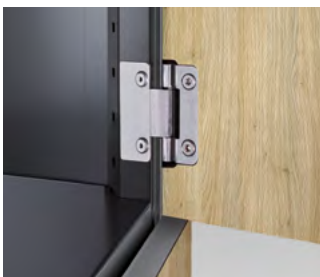

**Stainless steel hinge:**  
For HPL decor doors.



**Can be integrated into Cambio:** All common mechanical and electronic locking systems, from turning bolt latches to coin-operated locks to electronic locking systems as part of complete building automation (see p. 214).

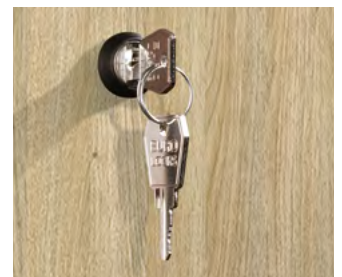
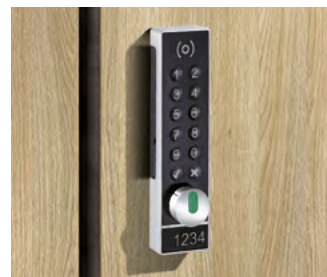

**Cylinder lock:**  
With 2 keys as standard equipment.



# C + P POWER LOCKERS

## Smart ventilation and drying with C + P power lockers.

Self-ventilation using the SVL concept was examined and confirmed with Cambio and Prefino from C + P.

Thanks to the flow behavior resulting from the design, damp clothing dries out considerably faster—guaranteed, and without any additional energy input! For special drying tasks, forced ventilation concepts with and without dryers are also available. We look forward to your handling your task.

### SVL

Self-ventilation



Our SVL technology means effective drying, without any additional ventilation equipment at all!

- + Can be used for 90% of all drying tasks
- + No customer-side requirements
- + Perforations positioned with ventilation in mind ensure optimal flow and efficient drying in the locker
- + Standard with Cambio and Prefino lockers

### FVL

Forced ventilation



Our FVL technology means a high air renewal rate thanks to connection to the customer's ventilation system.

- + Improved drying and odor elimination
- + Used in industrial plants and in foodstuff processing, for example
- + Extraction occurs by way of the customer's ventilation system (ideally with heat exchangers to reduce energy loss)
- + For optimal ventilation, we recommend an air renewal rate of 8 to 10 times per hour



## PERFORMANCE COMPARISON

All specifications and values assume a room temperature of approx. 20°C at a relative humidity of approx. 50% (common climate in Central Europe).

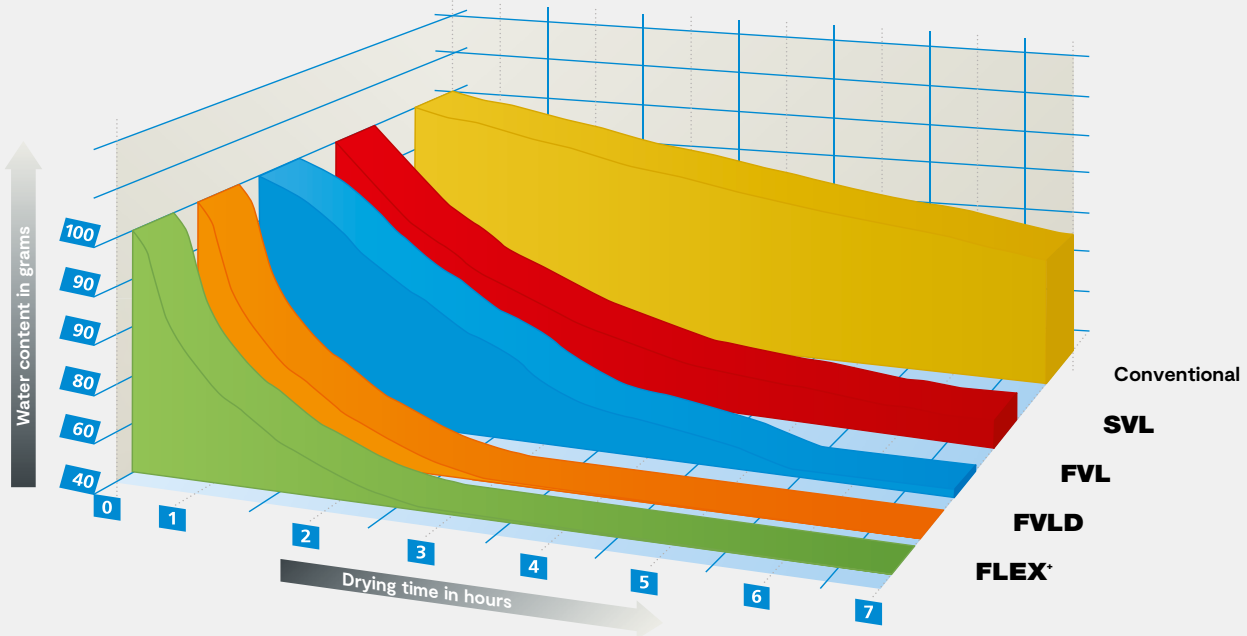

### FVLD

Forced ventilation with dryer

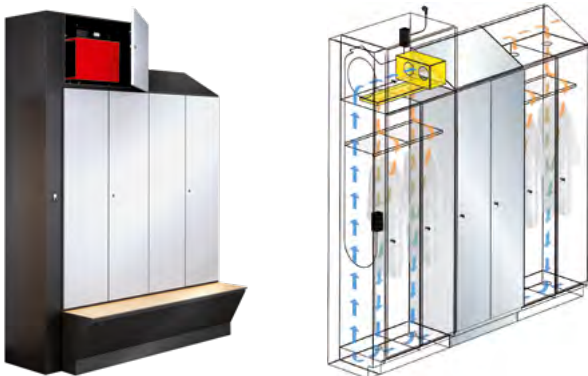

Our FVLD technology means maximum drying efficiency with minimal energy consumption.

- + Closed drying system for up to 15 compartments with integrated condensation dryer
- + Used at building yards, at road maintenance depots and in the construction industry, for example
- + Only a drain for condensation water and a power connection are required
- + Very energy efficient: The power consumption of the dryer is only 550 watts!
- + Up to 30 liters of water can be dried per day!
- + In addition to moisture, odors are also eliminated to a large degree
- + A separate, energy-hungry drying room is unnecessary.

### FLEX+

Drying and preheating



Our FLEX+ technology means high efficiency and optimum flexibility—the perfect solitary locker solution.

- + The right choice for places where employees get wet while working and need to dry out both their clothing and lots of protective gear for its next use, preheat it if desired and keep it securely locked up
- + A power connection's all that's needed
- + Drying, ventilation and heating can be controlled and programmed with an app in an energy-efficient way
- + Special interior for drying and preheating helmets, gloves and boots



# Cambio

## Lockers.

### Features of the Cambio series:

- + Sturdy steel construction with overlay doors and high-quality enamel coating
- + **Interior slopes in the body for high stability and easy, convenient clothing removal**
- + **Novel ventilation using the SVL concept as standard**
- + Steel fronts (single-walled, optionally double-walled and insulated) or optional HPL with wood decor for an even more attractive appearance
- + Door hinges for sheet metal doors made of aluminum/plastic
- + Door hinges for phenolic HPL decor fronts made of stainless steel
- + 90° door opening limiter for outstanding closing characteristics as standard
- + **Body, base and steel doors electrolytically zinc-plated as standard**
- + Cylinder lock with 2 keys
- + **Optimum air circulation thanks to defined ventilation spaces in front of and behind the bottom storage shelf**
- + Sturdy changing room rail with an oval profile, 4 anti-rotation hooks with system holder, e.g. for coat hangers or movable partitions
- + Wide variety of interior fitting solutions for any requirement
- + **Slot-in shoe shelf, easy to retrofit by the user**
- + Height adjustment using adjustable 130 mm-high plastic feet, easy to operate from inside and outside
- + Vertically adjustable base
- + Wear-resistant plastic feet ensure protection from corrosion
- + Sub-frame available with feet or base, as well as with spacious storage box or bench on request



- (A) Locker rows and individual lockers → p. 172
- (B) Corner lockers → p. 182
- (→) SVL concept® and drying guarantee as standard → p. 170

#### Door version:

- + Single-walled, reinforced steel doors as standard
- + Optional: Double-walled, insulated steel doors
- + Optional: HPL decor doors (standard with Z lockers)
- + Steel doors are 19 mm thick, HPL doors are 13 mm thick

### Dimensions and door material (A)

On 130 mm-high feet, depth: 525.  
Clear opening dimensions per door:  
1,757 x 262/362 x 480 (H x W x D),  
each compartment with storage shelf,  
changing room rail and 4 hooks

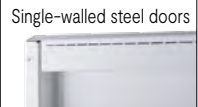
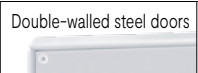
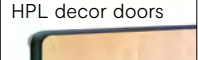

Height: 1,980	Compartments	1x 300	1x 400	2x 300	2x 400
	Width	300	400	600	800
	Order no.	45100-10	45100-12	45100-20	45100-22
	Price				
	& order no.	+ 45110-710	+ 45112-710	+ 45120-710	+ 45122-710
	& addtl. charge				
	& order no.	+ 45110-730	+ 45112-730	+ 45120-730	+ 45122-730
	& addtl. charge				

#### (→) Body and door color & decors

Color and decor concept → p. 48

HPL = high-pressure laminate



Order no. 45100-20



Order no. 45100-20  
& 45120-730 (HPL decor doors in sen ash)  
& 4500-700 (base)

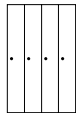
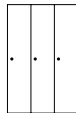
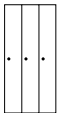

3 x 300	3 x 400	4 x 300
900	1200	1200
45100-30	45100-32	45100-40

+ 45130-710	+ 45132-710	+ 45140-710
-------------	-------------	-------------

+ 45130-730	+ 45132-730	+ 45140-730
-------------	-------------	-------------

**(+)** Base instead of feet, steel version, 100 mm high, vertically adjustable

Color (standard)	Black gray RAL 7021
Locker height	1950
& order no.	+ 4500-700
& addtl. charge	



**(+)** Accessories

Available upgrades, locks → p. 184

# Cambio

## Double-tier lockers.



Order no. 45101-20



Order no. 45101-30  
& 4500-700 (base)

### Dimensions and door material

2 box tiers  
On 130 mm-high feet, depth: 525.  
Clear opening dimensions per door:  
862x262/362x480 (HxWxD), each box  
with changing room rail and 4 hooks

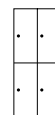
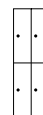

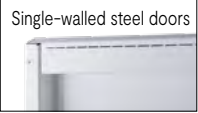
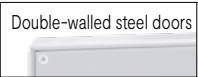
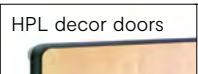
Height: 1,980	Compartments	1x300	1x400	2x300	2x400
	Width	300	400	600	800
	Order no.	45101-10	45101-12	45101-20	45101-22
	Price				
	& order no.	+ 45210-710	+ 45212-710	+ 45220-710	+ 45222-710
	& addtl. charge				
	& order no.	+ 45210-730	+ 45212-730	+ 45220-730	+ 45222-730
	& addtl. charge				

→ Body and door color & decors

Color and decor concept → p. 48

HPL = high-pressure laminate



Company

Color concept

Changing room & wardrobe

Workshop & factory

Office & archive

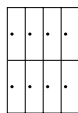
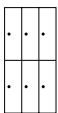

3 x 300

3 x 400

4 x 300

900

1200

1200

45101-30

45101-32

45101-40

+ 45230-710

+ 45232-710

+ 45240-710

+ 45230-730

+ 45232-730

+ 45240-730

**+ Base instead of feet,**  
steel version,  
100 mm high,  
vertically adjustable

Color (standard)

Black gray  
RAL 7021

Locker height

1950

& order no.

+ 4500-700

& addtl. charge



**+ Accessories**

Available upgrades, locks → p. 184



# Cambio

## Assembled box lockers.



Order no. 45102-30



Order no. 45103-22 & 4500-700 (base)

### Dimensions and door material

3 box tiers  
On 130 mm-high feet, depth: 525.  
Clear opening dimensions per door:  
562 x 262/362 x 480 (H x W x D),  
without interior fittings

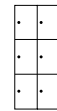
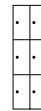

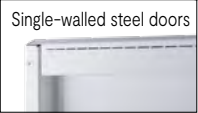
Height: 1,980	Compartments	1x 300	1x 400	2x 300	2x 400
	Width	300	400	600	800
	Order no.	45102-10	45102-12	45102-20	45102-22
	Price				

4 box tiers  
On 130 mm-high feet, depth: 525.  
Clear opening dimensions per door:  
412 x 262/362 x 480 (H x W x D),  
without interior fittings

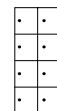
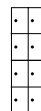
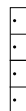

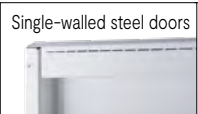
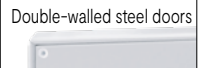
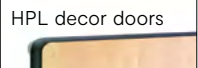
Height: 1,980	Compartments	1x 300	1x 400	2x 300	2x 400
	Width	300	400	600	800
	Order no.	45103-10	45103-12	45103-20	45103-22
	Price				
	Order no.	+ 45410-710	+ 45412-710	+ 45420-710	+ 45422-710
	& addtl. charge				
	Order no.	+ 45410-730	+ 45412-730	+ 45420-730	+ 45422-730
	& addtl. charge				

→ Body and door color & decors

Color and decor concept → p. 48

HPL = high-pressure laminate

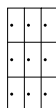

3 x 300
900
45102-30

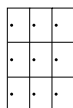

3 x 400
1200
45102-32

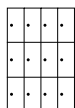

4 x 300
1200
45102-40



3 x 300
900
45103-30

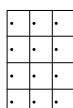

3 x 400
1200
45103-32

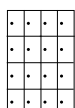

4 x 300
1200
45103-40

+ 45430-710
-------------

+ 45432-710
-------------

+ 45440-710
-------------

+ 45430-730
-------------

+ 45432-730
-------------

+ 45440-730
-------------

**+** Base instead of feet, steel version, 100 mm high, vertically adjustable

Color (standard)	Black gray RAL 7021
------------------	---------------------

Locker height	1950
---------------	------

& order no.	+ 4500-700
-------------	------------

& addtl. charge



**+** Accessories

Available upgrades, locks → p. 184

# Cambio

## Assembled box lockers.



Order no. 45104-20



Order no. 45105-30  
& 45630-730 (HPL decor doors in sen ash)

### Dimensions and door material

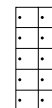
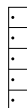

5 box tiers  
On 130 mm-high feet, depth: 525.  
Clear opening dimensions per door:  
322 x 262/362 x 480 (H x W x D),  
without interior fittings

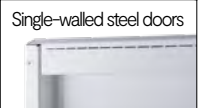

Height: 1,980	Compartments	1x 300	1x 400	2x 300	2x 400
	Width	300	400	600	800
	Order no.	45104-10	45104-12	45104-20	45104-22
	Price				

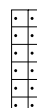
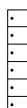
6 box tiers  
On 130 mm-high feet, depth: 525.  
Clear opening dimensions per door:  
262 x 262/362 x 480 (H x W x D),  
without interior fittings

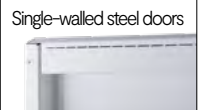

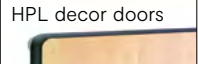
Height: 1,980	Compartments	1x 300	1x 400	2x 300	2x 400
	Width	300	400	600	800
	Order no.	45105-10	45105-12	45105-20	45105-22
	Price				
	Order no.	+ 45610-710	+ 45612-710	+ 45620-710	+ 45622-710
	& addtl. charge				
	Order no.	+ 45610-730	+ 45612-730	+ 45620-730	+ 45622-730
	& addtl. charge				

→ Body and door color & decors

Color and decor concept → p. 48

HPL = high-pressure laminate



Company

Color concept

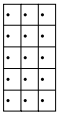

3 x 300
900
45104-30

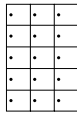

3 x 400
1200
45104-32

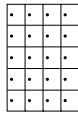

4 x 300
1200
45104-40

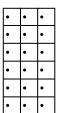

3 x 300
900
45105-30

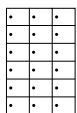

3 x 400
1200
45105-32

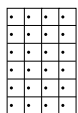

4 x 300
1200
45105-40

+ 45630-710
-------------

+ 45632-710
-------------

+ 45640-710
-------------

+ 45630-730
-------------

+ 45632-730
-------------

+ 45640-730
-------------

**+ Base instead of feet,**  
steel version,  
100 mm high,  
vertically adjustable

Color (standard)	Black gray RAL 7021
------------------	------------------------

Locker height	1950
---------------	------

& order no.	+ 4500-700
-------------	------------

& addtl. charge



Changing room & wardrobe

Workshop & factory

Office & archive

**+ Accessories**

Available upgrades, locks → p. 184



# Cambio

## Z lockers.

### Z lockers offer more:

- + Optimum use of the interior space for 2 users, with low floor-space requirements
- + For use in areas that only offer enough space for a double-tier locker but still require long items of clothing to be hung
- + **Lots of storage space!** Lots of storage space! Large, bulky bags or helmets, long garments, shoes and small objects all have their place
- + Great overview thanks to **functional division** in the locker
- + Each compartment has a rail with 3 hooks on the side
- + **HPL decor doors as standard**



Order no. 45180-224

### Dimensions and door material

On 130 mm-high feet, depth: 525.  
Each compartment has a rail with 3 hooks on the side

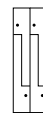

	Height: 1,980	Width	300	400	600	800
		Description	For 2 people	For 2 people	For 4 people	For 4 people
		Order no.	45180-132	45180-122	45180-234	45180-224
		Price				

On 130 mm-high feet, depth: 525.  
Two Z compartments each on the left and right, double-tier compartment in the center

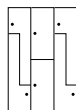
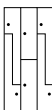

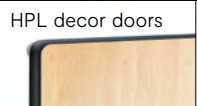
	Height: 1,980	Width	900	1200
		Description	For 6 people	For 6 people
		Order no.	45181-336	45181-326
		Price		

→ **Body and door color & decors**

Color and decor concept → p. 48

HPL = high-pressure laminate



Company

Color concept

Changing room & wardrobe

Workshop & factory

Office & archive

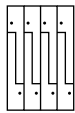
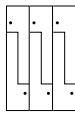
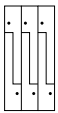

900

For 6 people

45180-336

1200

For 6 people

45180-326

1200

For 8 people

45180-438



The practical, sturdy changing room rail with an oval profile with 3 anti-rotation sliding hooks is very user-friendly and allows several garments to be hung spaced out.



Order no. 45181-326

**+** Accessories

Available upgrades, locks → p. 184

# Cambio

## Changing room corner lockers.

### Cambio creates spaces

It makes a big difference whether furniture is simply placed in a room or whether the furnishings become part of the overall interior architecture. Cambio meets all the requirements for harmoniously integrating into any desired environment.

Thanks to intelligent corner lockers which are flexible in use as an inside or outside corner, incomparable spatial experiences are created.

More than just a large number of available locker configurations are decisive for integration potential—the diversity of material options and the surface design also play a key role.

Please send us your project-specific request.

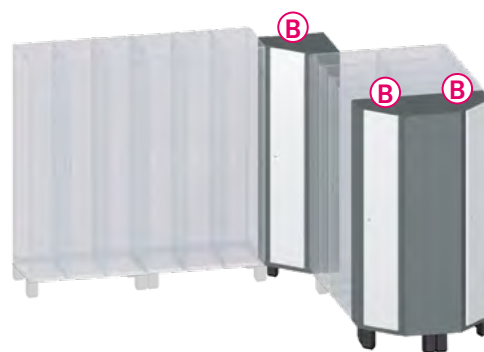





## Versions and accessories

- + **Sloping tops without a locker:** approx. 230 mm high in rear (nothing can be left on top of the locker!)

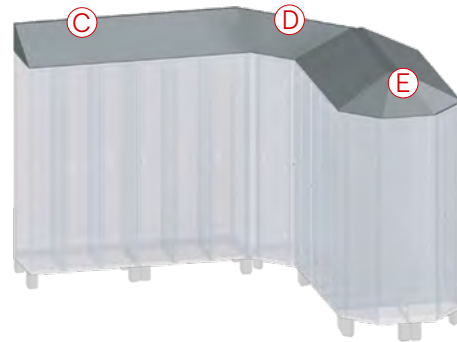
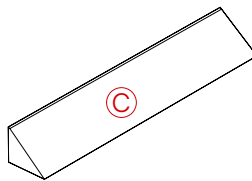

For locker width	300	400	600	800	900	1200	1200
For compartments	1x300	1x400	2x300	2x400	3x300	3x400	4x300
& order no.	+ 4531-70	+ 4541-70	+ 4532-70	+ 4542-70	+ 4533-70	+ 4543-70	+ 4534-70
& addtl. charge							

- + **Sloping tops**  
For corner on existing corner locker

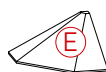

Version	Inside corner	Outside corner
Project-specific on request		

- + **Base instead of feet,** steel version, 100 mm high, vertically adjustable

Color (standard)	Black gray RAL 7021
Locker height	1950
& order no.	+ 4500-700
& addtl. charge	



- + **Pairs of doors closing in the middle\***  
Doors with joint lock, price per pair

For series	45100-20	45100-22
Locker width	600	800
& order no.	+ 45107-20	+ 45107-22
& addtl. charge		

- + **Base blanking panel**  
Black gray plastic, 60 or 100 mm high, with bottom sealing lip, self-adhesive

Per running meter	
60 mm high	100 mm high
+ 4400-7006	+ 4400-7002



HPL = high-pressure laminate

\*Longer delivery times possible

! All dimensions in mm, and all prices in Euros







# Cambio

## Accessories and available upgrades.

Experience this space-saving miracle.

Make optimal use of your C+P wardrobe and changing room lockers. With well-thought-out locker accessories from C+P, it's no problem. Versatile interior fitting solutions ensure that every bit of space is used. You'll be amazed at what else can fit into your C+P steel locker.

### Available upgrades in the locker

	<p><b>Shoe tray made of plastic, removable, with bottom spacers</b></p> 	<p><b>Coat hangers with laundry net</b> The classic variant, e.g. for bathrooms or wellness centers</p> 	<p><b>Coat hangers with multi-function hooks</b> As an alternative to the net, for example for areas with special hygiene requirements</p> 	<p><b>Towel hanger, movable, for easier drying of large towels</b></p> 
Order no.	4500-707	8501-04251	8501-04	4500-760
Price				

### Additional fittings in the housing

**Slot-in shoe shelf**

Installation height: approx. 250, easy to retrofit by the user

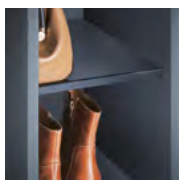

Version	Coated steel, black gray	
For compartment width	300	400
Order no.	4500-765	4500-766
Price		

**Outside shield panel,**

Additional charge per compartment, for compartment rear panel with back-to-back configuration



Version		
For compartment width	300	400
Order no.	4500-10	4500-11
Price		

**Partitions**

Below the storage shelf



Made of translucent plastic, movable and swivel design, low-maintenance

Partition, HxW	1210 x 300	
Order no.	4500-705	
Price		

**Side locker connection** (1 set for 2 lockers), for the connection of 2 lockers to one another

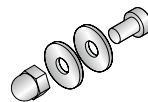

Order no.	4500-715
Price	



+ Labeling systems on request

## The easy way to keep things neat!

Use the door insides of your C + P changing room and locker furniture as an extra storage area.

### The benefits to you

- + More space inside
- + Accessories easy to reach
- + Neat storage, even of small items
- + User-friendly handling



Without additional equipment

With additional equipment

## Upgrades available for the locker door

**Towel holder**  
For steel and decor doors hinged on the **right**

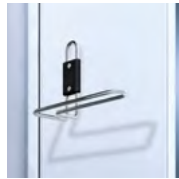

**Towel and shower gel holder**  
For steel and decor doors hinged on the **right**

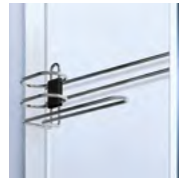

**Flip-flop and shoe holder**  
For steel and decor doors hinged on the **right**



For compartment width	300		400		300	400	300/400
Version <b>for steel doors</b>	Singled-walled	Double-walled	Singled-walled	Double-walled	Singled-walled	Singled-walled	Double-walled
Order no.	4500-775	4500-770R	4500-776	4500-771R	4500-777	4500-778	4500-773R
Price							
Version <b>for decor doors</b>	HPL doors		HPL doors		HPL doors		
Order no.	4500-7703R		4500-7713R		4500-7733		
Price							

### Mirror

For steel and decor doors, for attachment by customer



Width x Height	110 x 90	200 x 115
For compartment width	300/400	300/400
Version <b>for steel/decor doors</b>	Glass mirror, small	Polished metal mirror, large
Order no.	00018-00	00019-00
Price		

### + Locking systems

Selection → p. 214



# Prefino

## For the most stringent requirements.

**There are tasks that only specialists can handle. Furnishing changing rooms, for example.**

Where a crucial bit of extra space, functionality and design is needed—that's where Prefino comes into play.

- + Looking for attractive, uniform **glass fronts** with door mounts not visible from the outside?
  - + Looking for a **double-walled design** allowing you to route cables in a clean way or implement interior lighting, for example?
  - + Outfitting **areas with high hygienic requirements** and value smooth internal walls and locker floors, as well as face plates for **optimal cleaning and disinfection**?
  - + Looking for a **reconfigurable** modular system for complete flexibility and investment security as well?
  - + Seeking a broad a range of **locker variants** and available **door types and materials**?
  - + Want to make **special requests** a reality, like room lighting integrated into the locker top or custom-printed locker fronts?
- If so, Prefino from C + P is the right product range for you!

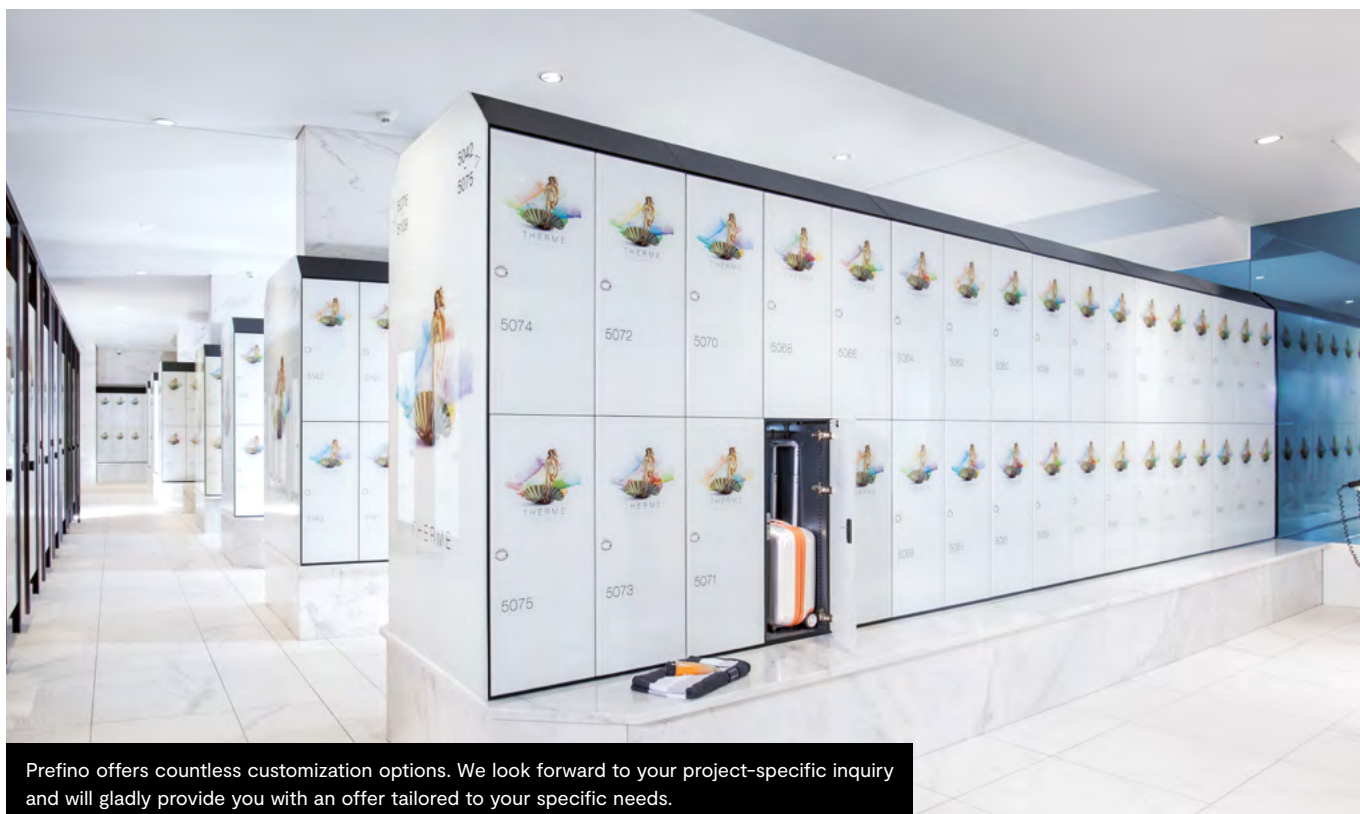

Prefino offers countless customization options. We look forward to your project-specific inquiry and will gladly provide you with an offer tailored to your specific needs.





Prefino →

Company

Color concept

Changing room & wardrobe



Workshop & factory

Office & archive



# Prefino



## Have a seat!

Depending on a building's design, a variety of different sub-frames can be utilized with locker systems. Prefino is flexible, making it well equipped for any challenge.

In addition to the classic foot and base designs, integrated bench solutions are becoming more and more commonplace. Whether it's overhanging benches on an existing base, benches built in front with locker doors reduced in size or benches with storage boxes underneath: Prefino is the best choice for ideal results.

All of the sub-frames shown here are very easy to clean, in part thanks to clear-cut corner solutions. This means extraordinary sanitary conditions and simple, fast and cost-effective cleaning as a result. The variant with storage boxes underneath also offers additional storage space that has generally gone unused—a true added benefit for visitors.

**We look forward to your project-specific inquiry.**



### **Bench with storage box underneath:**

The seat serves as a lid that can only be opened by the user of the locker. It ensures that bags, helmets and other items can be stored conveniently and removed easily.



## A clean solution.

In areas with high hygiene requirements (e.g. in the foodstuffs industry) locker systems require something special. As well, connecting to existing ventilation and extraction systems also requires a professional solution.



Company

Color concept

Changing room & wardrobe



Workshop & factory

Office & archive



# Flex PLUS drying locker

## Drying and heat with maximum flexibility.



**The right choice for places where employees get wet while working and need to dry out both their clothing and lots of protective gear for its next use, preheat it if desired and keep it securely locked up.**

Ambient air is drawn in and fed into the locker interior through the ventilation/heating element integrated in the slanted roof. Here, it exits through various air outlets like pipes/holders for boots, helmets etc. The extracted humidity escapes into the surrounding room, which has a positive effect on the room climate in the winter when heating air is dry. Dripping water is led downward out of the compartment via the perforated stainless steel tray.

The hours of operation can be conveniently controlled with an app. Independent program circuits for ventilation and heating ensure energy-saving and efficient use. With optionally available 230-volt sockets, additional electrification for charging e-bike and other mobile batteries is possible, for example.

Number per locker		2 compartments for 2 people	2 compartments for 1 person
Helmet holder		2x	1x
Upper storage shelf		–	1x
Hinged floor		2x	1x
Glove holder		4x	4x
Side hook rail		2x	1x
Perforated stainless steel tub		2x	2x
Sockets in compartment		Optionally available	
Drying coat hanger		–	2x
Metal mirror, large		2x	1x
Small-part repository		2x	1x
Lock with 2 keys		2x	1x
Boot holder		4x	4x

## Product information

- + Flex PLUS technology enables the fastest possible drying of work clothing. Wet clothing is usually dried especially energy efficiently within 1 to 3 hours!
- + The electrical consumption of the ventilation/heating element integrated in the slanted roof is less than 0.15 W in standby, 8.8 W in ventilation mode and 1,000 W in heating mode
- + Sturdy steel construction with multi-functional modular system, overlay doors and high-quality enamel coating
- + Body height: 2,100 mm (2,200 mm incl. feet, 2,350 mm including slanted roof)
- + Body and steel doors electrolytically zinc-plated as a standard
- + Fronts made of steel or HPL with wood decor for an even more attractive appearance
- + Double-walled design for high stability
- + Smooth interior walls—hygienic and easy to clean
- + Perforated storage shelf for improved ventilation
- + Convenient operation of the control unit with an app (Apple or Android), each locker individually operable
- + Connection cable with grounded plug, approx. 5 m long.

## Versions

### 2 compartments for 2 people

Compartment width: 350 mm



- Per compartment:**
- 1 x helmet holder
  - 2 x glove holders
  - 2 x boot holders
  - 1 x hinged floor
  - 1 x hook rail
  - 1 x stainless steel tub
- Door**
- 1 x mirror (per door)
  - 1 x small-part tray
  - 1 x lock

H 2,350xW 700xD 600

**On feet**

Order no. (steel doors) 46113-2118

Price

Order no. (HPL doors) 46121-730

& addtl. charge

### 2 compartments for 1 person

Compartment width: 350 mm



- Left compartment:**
- 1 x helmet holder
  - 4 x glove holders
  - 4 x boot holders
  - 1 x hinged floor
  - 1 x stainless steel tub

- Right compartment:**
- 1 x storage shelf
  - 2 x drying coat hanger
  - 1 x hook rail
  - 1 x stainless steel tub

**Door**

- 1 x mirror
- 1 x small-part tray
- 1 x lock

H 2,350xW 700xD 600

**On feet**

Order no. (steel doors) 46112-21181

Price

Order no. (HPL doors) 46121-730

& addtl. charge



**Our energy-saving tip for guaranteed drying:**

3 hours of ventilator drying in the evening, 1/2 hour of drying with heated air in the morning, controllable with an app.

### Drying diagram



**Clothing**

Measurement conditions: 22°C and 48% relative humidity

Liquid volume: 100 ml

- Drying with heated air (38°C)
- Drying with air at room temperature
- No additional measures

Liquid in ml

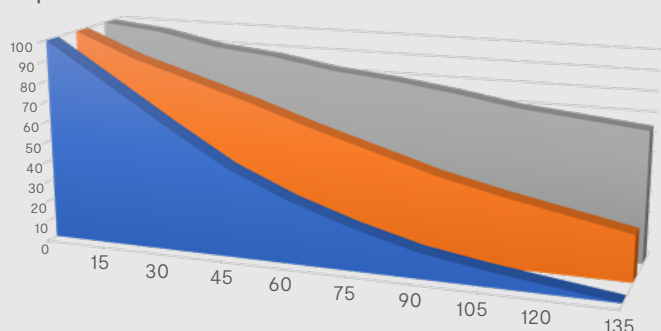



# School and assembled box lockers



## Assembled box lockers in sideboard height Kindergarten/elementary school lockers

### Intro

#### The sturdy classic lockers with many different box sizes

- + Sturdy steel construction with high-quality enamel coating
- + 6 box heights, 2 box widths, 2 box depths for any requirement
- + Can also be used as wardrobe locker
- + Doors are single- or double-walled, depending on the box size, mounted on a sturdy strap hinge, with 170° door opening
- + Attractive locker base in black gray
- + Each box has cylinder lock and 2 keys
- + Other locks available: turning bolt, safety turning bolt, master key system and Safe-O-Mat locks
- + Also available with doors made of acrylic glass, available with 90° door opening limiter as standard

#### The “short ones” for the little ones

- + Series descriptions:  
See Intro and Resisto
- + Intro series: 1 box size  
Resisto series: 3 box sizes
- + Decor top cover in MCPB (melamine coated particle board) 25 mm thick
- + Kindergarten locker, 300 mm deep, single- and double-tier
- + Elementary school locker, 500 mm deep, single- and double-tier

	Single-walled doors	Double-walled doors	Doors with acrylic glass	“Tamper resistant” doors	Door opening angle: 170°	Integrated door opening limiter
Intro Assembled box lockers	●	●	●	–	●	90°*
Intro school lockers	–	●	–	–	●	90°
Kindergarten and elementary school lockers	●	–	–	–	–	Optional
Resisto school lockers	–	–	–	●	–	80°
Resisto assembled box lockers	–	–	–	●	–	80°

\*For doors with acrylic glass only



Classic PLUS assembled box lockers → p. 80

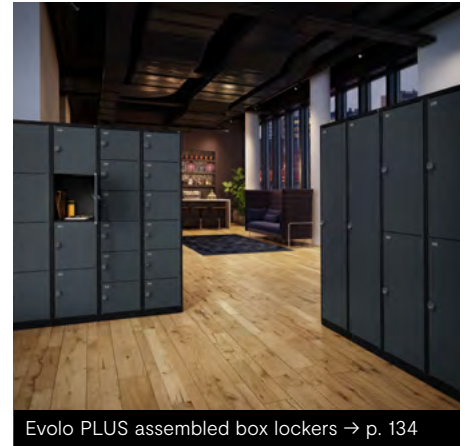

EvoLo PLUS assembled box lockers → p. 134

## Resisto

### The “tamper resistant” lockers with special doors

- + Sturdy steel construction with high-quality enamel coating
- + 3 box heights and 3 box depths for any requirement
- + “Tamper resistant” special doors made of steel 1.5 mm thick, curved to the front, mounted on sturdy swivel-rod hinges (kick-resistant!)
- + Integrated 80° door opening limiter as standard
- + Locker base in color of the body
- + Each box has cylinder lock and 2 keys
- + Other locks available: turning bolt, safety turning bolt, master key system and Safe-O-Mat locks
- + 30 mm height adjustment

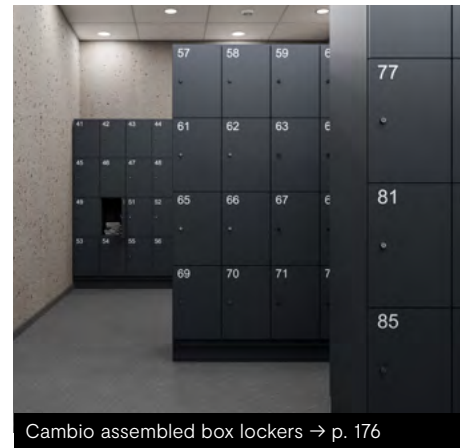

Cambio assembled box lockers → p. 176

Door mounting bracket  
on strap hinges

Door mounting bracket  
on swivel rod hinges

Different  
box sizes

Compartments for  
motorcycle helmets

Top cover  
(MCPB)

Base  
100 mm

Feet

Height  
leveling

Lock  
variants

●	–	●	W 400	–	●	–	–	●
●	–	–	W 400	●	●	–	–	●
–	–	●	–	–	●	●	–	Optional
–	●	●	W 380	●	●	–	●	●
–	●	●	W 380	–	●	–	●	●

# Intro

## Assembled box lockers.

### Features of the Intro series:

- + Sturdy steel construction with high-quality enamel coating
- + 6 box heights, 2 box widths, 2 box depths for any requirement
- + All lockers with attractive base, 100 mm high, in black gray
- + Doors single-walled or double-walled (see individual descriptions)
- + Each door has cylinder lock and 2 keys
- + Other lock types available, e.g. coin-operated lock
- + Each door mounted and hinged on the right with sturdy strap hinges, door opening angle of 170°
- + All lockers with louvers in the rear panel and 20 mm wall spacer (absolute body depth: approx. 480 mm)



Order no. 8270-201

### Dimensions and version

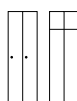

With base	Boxes	2	3	4
Base height: 100	Width	620	920	1220
Locker height: 1,950	Clear opening dimensions per door, H x W x D	1825 x 260 x 460	1825 x 260 x 460	1825 x 260 x 460
Locker depth: 500	Description	With <b>full-length doors</b> , 1 storage shelf and 1 sturdy changing room rail with an oval profile inside with 3 anti-rotation sliding hooks		
<b>Single-walled doors, reinforced</b>	Order no.	8170-201	8170-301	8170-401
	Price			



With base	Boxes	8	12	16
Base height: 100	Width	620	920	1220
Locker height: 1,950	Clear opening dimensions per door, H x W x D	435 x 260 x 460	435 x 260 x 460	435 x 260 x 460
Locker depth: 500	Description	With <b>4 box tiers</b>		
<b>Double-walled doors</b>	Order no.	8470-201	8470-301	8470-401
	Price			

→ Body and door color

Color concept → p. 48



Order no. 8570-401

**+ Sloping top (retrofitable)**  
Prevents objects from being left on top & rear approx. 230 mm high & for body depth 480 mm

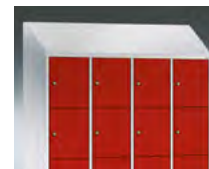

For locker width	620	920	1220
Order no.	+ 8504-201	+ 8504-301	+ 8504-401
& addtl. charge			

4	6	8	6	9	12
620	920	1220	620	920	1220
895x260x460	895x260x460	895x260x460	580x260x460	580x260x460	580x260x460
<b>With 2 box tiers,</b> 1 sturdy changing room rail with an oval profile inside with 3 anti-rotation sliding hooks			<b>With 3 box tiers</b>		
8270-201	8270-301	8270-401	8370-201	8370-301	8370-401

10	15	20	12	18	24
620	920	1220	620	920	1220
345x260x460	345x260x460	345x260x460	285x260x460	285x260x460	285x260x460
<b>With 5 box tiers</b>			<b>With 6 box tiers</b>		
8570-201	8570-301	8570-401	8670-201	8670-301	8670-401

**+ Accessories**

Selection → p. 201





Order no. 8370-302



Order no. 8470-203

## Dimensions and versions

Single-walled doors, reinforced



### With base

Base height: 100  
Locker height: 1,950

Boxes	4	4	6	6
Width	820	820	1220	1220
Depth	500	600	500	600
Clear opening dimensions per door, HxWxD	895 x 360 x 460	895 x 360 x 560	895 x 360 x 460	895 x 360 x 560
Description	With <b>2 box tiers</b> , 1 sturdy changing room rail with an oval profile inside with 3 anti-rotation sliding hooks			
Order no.	8270-202	8270-203	8270-302	8270-303
Price				



### With base

Base height: 100  
Locker height: 1,950

Boxes	8	8	12	12
Locker width	820	820	1220	1220
Depth	500	600	500	600
Clear opening dimensions per door, HxWxD	435 x 360 x 460	435 x 360 x 560	435 x 360 x 460	435 x 360 x 560
Description	With <b>4 box tiers</b>			
Order no.	8470-202	8470-203	8470-302	8470-303
Price				

→ Body and door color

Color concept → p. 48



Company

Color concept

Changing room & wardrobe

Workshop & factory

Office & archive



6	6	9	9
820	820	1220	1220
500	600	500	600
580x360x460	580x360x560	580x360x460	580x360x560
<b>With 3 box tiers</b>			
8370-202	8370-203	8370-302	8370-303



10	10	15	15
820	820	1220	1220
500	600	500	600
345x360x460	345x360x560	345x360x460	345x360x560
<b>With 5 box tiers</b>			
8570-202	8570-203	8570-302	8570-303

**+** Accessories

Available upgrades, locks → p. 201

# Intro

## Features of the Intro series with acrylic glass doors:

- + Sturdy steel construction with high-quality enamel coating
- + 2 locker widths and 2 box heights for any requirement
- + All lockers with attractive base, 100 mm high, in black gray
- + Doors made of 8 mm-thick acrylic glass, outfitted with 90° door opening limiter as standard
- + Each door has cylinder lock and 2 keys
- + Other lock types available, e.g. coin-operated lock
- + Every door mounted and hinged on the right with sturdy strap hinges
- + All lockers with louvers in the rear panel and 20 mm wall spacer (absolute body depth: approx. 480 mm)



Order no. 8470A302

## Dimensions and versions

With acrylic glass doors and  
3 or 4 box tiers



With base	Boxes	6	9	8	12
Base height: 100	Width	820	1220	820	1220
Locker height: 1,750	Clear opening dimensions per door, H x W x D	510 x 360 x 460	510 x 360 x 460	380 x 360 x 460	380 x 360 x 460
Locker depth: 500	Description	With 3 box tiers		With 4 box tiers	
	Order no.	8370A202	8370A302	8470A202	8470A302
	Price				





Company

Color concept

Changing room & wardrobe

Workshop & factory

Office & archive

⊕ Accessories

Available upgrades, locks → p. 201



## Features of the Intro series:

- + Sturdy steel construction with high-quality enamel coating
- + Boxes easy for children to reach
- + Assembled box lockers with decor top cover made of MCPB (melamine coated particle board)
- + All lockers with attractive base, 100 mm high, in black gray
- + Double-walled doors, with 90° door opening limiter as standard
- + Each door has cylinder lock and 2 keys
- + Each door mounted and hinged on the right with sturdy strap hinges
- + All lockers with louvers in the rear panel and 20 mm wall spacer (absolute body depth: approx. 480 mm)
- + Top covers feature 20 mm projection in the rear as standard to avoid a gap between the wall and locker, e.g. due to baseboard (top depth: 500 mm)



Order no. 8573-201



Order no. 8573-301 & 8573-7301 (top cover without rear projection)

## Dimensions and versions

With 3 box tiers with 25 mm-thick MCPB decor top cover, double-walled doors



With base	Boxes	6	9
Base height: 100	Width	620	920
Locker height: 1,250	Clear opening dimensions per door, HxWxD	345 x 260 x 460	345 x 260 x 460
Locker depth: 500	Description	With 3 box tiers	With 3 box tiers
	Order no.	8573-201	8573-301
	Price		

⊕ **Top covers without projection in rear**  
 Flush with body on all sides,  
 please specify top decor → p. 52





For locker width	620	920
Top depth	480	480
Order no.	8573-7201	8573-7301
& addtl. charge		





→ **Body and door color**

Color concept → p. 48

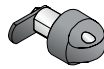
## Cylinder locks and turning bolt latch

Prices per lock	Basic design	Optional		
	Cylinder lock	Cylinder lock in black with 2 keys	Turning bolt latch	Safety turning bolts
				
	Up to 1,000 different key numbers	Via master key system with security certificate*	Via master key system without security certificate	For padlock (see also Page 83)
Order no.	8077-30	8000-01	8000-001	0003-00
Price				8000-718

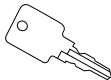
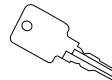
## Keys and wristband for cylinder locks

Spare key for rotary cylinder lock	Master key for master key system	Perlon wristband for cylinder key	
			
Spare key for lock 8077-30	With security certificate*	Without security certificate	
Order no.	0006-21	0011-00	0012-00
Price			8501-0551

- Color no.**
- 51 Black
  - 52 White
  - 53 Red
  - 55 Blue
  - 61 Green
  - 67 Yellow



**Color: 51 black;** other colors no addtl. charge, **change color no.** at end of order no. Please specify desired numbers!



**+ SAFE-O-MAT locks**  
To overview → p. 219

## Padlocks

For turning and safety turning bolt, bolt size: approx. 6 mm

		
Padlock, brass version, 2 keys	Safety lock made of brass, precision cylinder, 2 keys	BURG number CODE-lock with hardened steel shackle
Key numbers	Up to 300	Up to 168,000
Order no.	0002-10	0002-11
Price		00002-14

## Lock no. as per customer request

For cylinder lock (longer delivery time)  
Addtl. charge per lock

Order no. ...-...99  
& addtl. charge On request

## Number plates

Please specify numbers

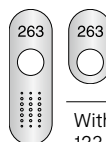

Number plates in lock area, self-adhesive, loose for easy attachment, suitable for cylinder locks only

With integrated door protection, 123 x 39 x 1.0 mm

Without integrated door protection, 68 x 39 x 1.0 mm

Stainless steel number plate self-adhesive, 30 x 50 x 1.0 mm

**263**

Version	Plastic	Stainless steel	Plastic	Stainless steel
Order no.	4902-0601	4901-0601	4902-0611	4901-0611
Price				8501-06

**+ Additional door protection/number plate**



\*Considerably longer delivery time, brass key

**!** All dimensions in mm, and all prices in Euros

# Daycare lockers

## 300 mm deep.

### Features of the kindergarten lockers:

- + Sturdy steel construction with high-quality enamel coating
- + All compartments are easy to reach for children, making them ideal for use at kindergartens and daycares
- + Available in 2 versions with full-length doors and 2 doors arranged vertically (double-tier)
- + Either with feet or base as sub-frame
- + Doors hinged on the right, mounted on fulcrum pins, with easy-to-clean hole pattern
- + Version without label holder for customer labeling
- + Convenient doorstop silencer for pleasant closing
- + Interior is easy to clean, as compartment shelves can be swept out easily



Order no. 480103-20

### Variant: with full-length door

#### Dimensions and version

With safety turning bolt  
Clear opening dimensions per door:  
1,105x230x265 (HxWxD)



#### With feet

Locker height: 1,350  
Locker depth: 300  
Foot height: 150

Compartments	1x300	2x300	3x300	4x300
Locker width	320	610	900	1190
Order no.	480103-10	480103-20	480103-30	480103-40
Price				

#### With base

Locker height: 1,300  
Locker depth: 300  
Base height: 100

Compartments	1x300	2x300	3x300	4x300
Locker width	320	610	900	1190
Order no.	480203-10	480203-20	480203-30	480203-40
Price				

→ Body and door color

Color concept → p. 48



Order no. 483203-30

- + Compartments with a sturdy changing room rail with an oval profile and 3 anti-rotation sliding hooks with system holder, e.g. for coat hangers
- + Also 1 storage shelf per compartment in models with full-length doors, internal height above the storage shelf: 320 mm
- + Ergonomic safety turning bolt latch for padlock with door protection as practical basic fittings
- + Locker feet (e.g. in model 480103) made of plastic for improved corrosion protection of the locker!
- + Feet in light gray with body color RAL 7035, in black for all other body colors



### 90° door opening limiter

Price per door

Version	90°
+ Order no.	+ 8505-02
+ Addtl. charge	

## Variant: double-tier

### Dimensions and version

With safety turning bolt  
Clear opening dimensions per door:  
536x230x265 (HxWxD)



With feet	Compartments	1x300	2x300	3x300	4x300
Locker height: 1,350	Locker width	320	610	900	1190
Locker depth: 300	Order no.	483103-10	483103-20	483103-30	483103-40
Foot height: 150	Price				

With base	Compartments	1x300	2x300	3x300	4x300
Locker height: 1,300	Locker width	320	610	900	1190
Locker depth: 300	Order no.	483203-10	483203-20	483203-30	483203-40
Base height: 100	Price				



# Elementary school lockers

## 500 mm deep.

### Features of the elementary school lockers:

- + Sturdy steel construction with high-quality enamel coating
- + Bottom and locker floor generally zinc-plated for increased corrosion protection
- + All compartments easy for elementary school students to reach
- + Break-in-resistant design as per class C according to DIN 4547
- + Reinforced doors hinged on the right with doorstop silencer, ventilation hole pattern and safety turning bolt latch for padlock
- + 90° door opening limiter as standard
- + Version without label holder for customer labeling
- + Single-tier lockers: Inside each compartment: 1 non-adjustable storage shelf, sturdy changing room rail with 3 anti-rotation double sliding hooks below
- + Double-tier lockers: Inside each box: 1 sturdy changing room rail with 3 anti-rotation double sliding hooks



### Variant: with full-length door

#### Dimensions and version

With safety turning bolt  
Clear opening dimensions per door:  
1,429 x 240 x 477 (H x W x D)



Floor-standing	Compartments	1x300	2x300	3x300	4x300
Locker height: 1,530	Locker width	320	600	900	1200
Locker depth: 500	Order no.	0490005-10	0490005-20	0490005-30	0490005-40
	Price				

With feet	Compartments	1x300	2x300	3x300	4x300
Locker height: 1,630	Locker width	300	600	900	1200
Locker depth: 500	Order no.	0490105-10	0490105-20	0490105-30	0490105-40
Foot height: 100	Price				

With base	Compartments	1x300	2x300	3x300	4x300
Locker height: 1,630	Locker width	320	600	900	1200
Locker depth: 500	Order no.	0490205-10	0490205-20	0490205-30	0490205-40
Base height: 100	Price				

→ Body and door color

Color concept → p. 48



Version with base

- + Compartment bottoms can be swept out easily
- + Slim lateral edges for a homogeneous look when lined up next to one another without doubling at the locker joints
- + Additional ventilation thanks to ventilation openings in compartment bottom and top as self-ventilation concept through structurally optimized air flow behavior
- + Available with feet or with base
- + Standard level adjustment
- + Plastic feet, base featuring increased corrosion protection, both for body RAL 7035 in light gray, otherwise in black gray



90° door opening limiter as standard equipment

## Variant: double-tier Dimensions and version

With safety turning bolt  
Clear opening dimensions per door:  
694x240x477 (HxWxD)



Floor-standing	Compartments	1x300	2x300	3x300	4x300
	Locker height: 1,530	Locker width	300	600	900
Locker depth: 500	Order no.	0493005-10	0493005-20	0493005-30	0493005-40
	Price				

With feet	Compartments	1x300	2x300	3x300	4x300
	Locker height: 1,630	Locker width	300	600	900
Locker depth: 500	Order no.	0493105-10	0493105-20	0493105-30	0493105-40
Foot height: 100	Price				

With base	Compartments	1x300	2x300	3x300	4x300
	Locker height: 1,630	Locker width	300	600	900
Locker depth: 500	Order no.	0493205-10	0493205-20	0493205-30	0493205-40
Base height: 100	Price				

# Resisto

## Half-height lockers.

### Features of Resisto-series half-height lockers:

- + Sturdy steel construction with high-quality enamel coating
- + **All boxes are easy to reach for children, making them ideal for use in schools and childcare facilities**
- + 2 different depths: 540 and 640 mm (absolute body depths of 480 and 580 mm)
- + **640 mm depth ideally suited for storing large gym bags**
- + Assembled box lockers feature decor top cover made of 25 mm-thick MCPB (melamine coated particle board)
- + All lockers feature attractive, 100 mm-high base
- + in same color as body and 30 mm level adjustment
- + **Special doors made of 1.5 mm-thick steel, curved to the front, absolutely sturdy and “tamper resistant”**
- + Right-opening with sturdy swivel rod hinge
- + Each door features cylinder lock and 2 keys
- + Integrated 80° door opening limiter and wall mounting as standard
- + Other lock types such as coin-operated locks and electronic locking systems also available
- + Lockers feature louvers in the rear panel and 20 mm wall spacer
- + Top covers feature 20 mm projection in the rear as standard

### Dimensions and design

#### With full-length doors

On 100 mm-high base, 1 changing room rail with 3 sliding hooks inside each box, with MCPB decor top cover



Height: 1,070	Boxes	2	2	3	3
	Width	770	770	1150	1150
	Depth	540	640	540	640
	Clear opening dimensions per door, HxWxD	870 x 320 x 460	870 x 320 x 560	870 x 320 x 460	870 x 320 x 560
	Description	With <b>2 adjacent boxes</b>		With <b>3 adjacent boxes</b>	
	Order no.	8271-272	8271-273	8271-372	8271-373
	Price				



Order no. 8472-372  
& 8573-7372 (top cover without projection in rear)



Order no. 8573-372  
& 8573-7372 (top cover without projection in rear)

→ **Body and door color & decors**

Color and decor concept → p. 48

This series offers additional box volume for greater storage needs



**“Tamper resistant”:**  
1.5 mm-thick curved steel doors make Resisto extremely sturdy



**Top cover:**  
Durable MCPB tops protect the upper surfaces of the half-height lockers



## Dimensions and design

### With 2 box tiers

On 100 mm-high base, with MCPB decor top cover



Height: 1,070	Boxes	4	4	6	6
	Width	770	770	1150	1150
	Depth	540	640	540	640
	Clear opening dimensions per door, HxWxD	420x320x460	420x320x560	420x320x460	420x320x560
	Description	With <b>2 adjacent boxes</b>		With <b>3 adjacent boxes</b>	
	Order no.	8472-272	8472-273	8472-372	8472-373
	Price				

## Dimensions and design

### With 3 box tiers

On 100 mm-high base, with MCPB decor top cover



Height: 1,250	Boxes	6	6	9	9
	Width	770	770	1150	1150
	Depth	540	640	540	640
	Clear opening dimensions per door, HxWxD	336x320x460	336x320x560	336x320x460	336x320x560
	Description	With <b>2 adjacent boxes</b>		With <b>3 adjacent boxes</b>	
	Order no.	8573-272	8573-273	8573-372	8573-373
	Price				

+ Accessories

Locks → p. 212

+ Top covers  
Without projection in rear

Selection → p. 212



# Resisto

## Assembled box lockers.

### Features of the Resisto series:

- + Sturdy steel construction with high-quality enamel coating
- + 2, 4 or 5 box tiers and 2 different depths: 540 and 640 mm (absolute body depths of 480 and 580 mm)
- + All lockers feature attractive, 100 mm-high base in same color as body and 30 mm level adjustment
- + **Special doors made of 1.5 mm-thick steel, curved to the front, absolutely sturdy and “tamper resistant”**
- + Right-opening with sturdy swivel rod hinge
- + Each door features cylinder lock and 2 keys
- + Standard 80° door opening limiter with soft doorstop and wall mounting
- + Other lock types such as coin-operated locks and electronic locking systems also available
- + Lockers feature louvers in rear panel and 20 mm wall spacer



**640 mm deep:**  
This extra-spacious variant of the Resisto series with a depth of 640 mm holds even large gym bags comfortably.

### Dimensions and design

**With 4 box tiers**  
On 100 mm-high base



	Height: 1,950	Boxes	4	4	8	8
		Width	396	396	770	770
		Depth	540	640	540	640
		Clear opening dimensions per door, HxWxD	420 x 320 x 460	420 x 320 x 560	420 x 320 x 460	420 x 320 x 560
		Description	With <b>4 boxes</b>		With <b>2 adjacent boxes</b>	
		Order no.	8470-172	8470-173	8470-272	8470-273
		Price				

### Dimensions and design

**With 5 box tiers**  
On 100 mm-high base



	Height: 1,950	Boxes	5	5	10	10
		Width	396	396	770	770
		Depth	540	640	540	640
		Clear opening dimensions per door, HxWxD	336 x 320 x 460	336 x 320 x 560	336 x 320 x 460	336 x 320 x 560
		Description	With <b>5 boxes</b>		With <b>2 adjacent boxes</b>	
		Order no.	8570-172	8570-173	8570-272	8570-273
		Price				

→ **Body and door color**

Color concept → p. 48



Order no. 8470-272



12	12
1150	1150
540	640
420 x 320 x 460	420 x 320 x 560
With 3 adjacent boxes	
8470-372	8470-373



15	15
1150	1150
540	640
336 x 320 x 460	336 x 320 x 560
With 3 adjacent boxes	
8570-372	8570-373



Order no. 8570-372



**+ Additional accessories**

Locks & number plates → p. 212

**+ Sloping top and upgrades**

Selection → p. 212

# Resisto

## Extra-large assembled box lockers.

### Dimensions and design

#### Double-tier

On 100 mm-high base, 1 changing room rail with 3 sliding hooks inside each box



Height: 1,950

Boxes	2	2	4	4
Width	396	396	770	770
Depth	540	640	540	640
Clear opening dimensions per door, HxWxD	870 x 320 x 460	870 x 320 x 560	870 x 320 x 460	870 x 320 x 560
Description	With <b>2 boxes</b>		With <b>2 adjacent boxes</b>	
Order no.	8270-172	8270-173	8270-272	8270-273
Price				



### Dimensions and design

#### Combination lockers

On 100 mm-high base



Height: 1,950

Width	1150	1150	1150	1150
Depth	540	640	540	640
Clear opening dimensions per door, HxWxD	420/870 x 320 x 460	420/870 x 320 x 560	420/870 x 320 x 460	420/870 x 320 x 560
Description	With <b>2 + 4 + 2</b> boxes, 1 changing room rail with 3 sliding hooks inside each large box		With <b>4 + 2 + 4</b> boxes, 1 changing room rail with 3 sliding hooks inside each large box	
Order no.	8070-3722	8070-3732	8070-3723	8070-3733
Price				



### Dimensions and design

#### Combination lockers

On 100 mm-high base

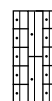
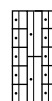
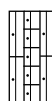
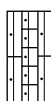

Height: 1,950

Width	1150	1150	1150	1150
Depth	540	640	540	640
Clear opening dimensions per door, HxWxD	336/870 x 320 x 460	336/870 x 320 x 560	336/870 x 320 x 460	336/870 x 320 x 560
Description	With <b>2 + 5 + 2</b> boxes, 1 changing room rail with 3 sliding hooks inside each large box		With <b>5 + 2 + 5</b> boxes, 1 changing room rail with 3 sliding hooks inside each large box	
Order no.	8070-3720	8070-3730	8070-3721	8070-3731
Price				



→ Body and door color

Color concept → p. 48



6	6
1150	1150
540	640
870x320x460	870x320x560
With 3 adjacent boxes	
8270-372	8270-373



Integrated 80° door opening limiter



Order no. 8270-272 with special equipment (Safe-O-Tronic locks)

## Extra-large assembled box lockers

These lockers offer additional box volume — for example as bag lockers at fitness centers, where they hold even large gym bags comfortably, or for large backpacks in school lockers.



Order no. 8070-3733



Order no. 8070-3730 With special equipment (Safe-O-Tronic locks)

+ Sloping top and accessories

Selection → p. 212



# Resisto

## Accessories and locks.

### Sloping top

Approx. 230 mm high in the rear, for retrofitting, prevents objects from being left on top, body depth of 480/580

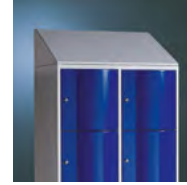
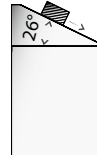

For locker width	396	396	770	770	1150	1150
For body depth	480	580	480	580	480	580
Order no.	8504-172	8504-173	8504-272	8504-273	8504-372	8504-373

Price

### Top covers without projection in rear

Flush with body on all sides, for half-height lockers from p. 206. Please specify top decor, see p. 52

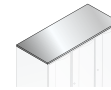

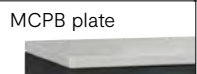

 MCPB plate	For locker width	770	770	1150	1150
	Top depth	480	580	480	580
	Thickness: 25 mm	•	•	•	•
	& order no.	+ 8573-7272	+ 8573-7273	+ 8573-7372	+ 8573-7373
	& addtl. charge				

MCPB = Melamine coated particle board

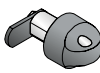

## Cylinder locks and turning bolt latch

Prices per lock	Basic design	Optional			
	Cylinder lock 	Cylinder lock in black with 2 keys 	Turning bolt latch 	Safety turning bolts 	
	Up to 6,000 different key numbers	Via master key system <b>with</b> security certificate*	Via master key system <b>without</b> security certificate	For padlock	For padlock
Order no.	8570-70	8570-711	8570-710	0003-00	8500-718
Price					

## Keys and wristband for cylinder locks

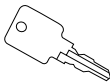
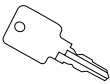
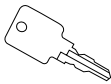
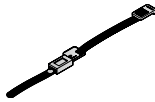
	Spare key for cylinder lock 	Spare key for master key system 	Master key for master key system 		Perlon wristband for cylinder keys 	
	Spare key for lock 8570-70	<b>With</b> security certificate*	<b>Without</b> security certificate*	<b>With</b> security certificate*	<b>Without</b> security certificate*	
					<b>Color: 51 black;</b> other colors no addtl. charge, <b>change color no.</b> at end of order no.: 51 black, 52 white, 53 red, 55 blue, 61 green, 67 yellow	
					Please specify desired numbers!	
Order no.	0006-21	0010-11	0006-00	0011-00	0012-00	8501-0551
Price						



### Optional accessories and padlocks

For turning bolts and safety turning bolts, bolt size: approx. 6 mm.

Key numbers

Order no.

Price

			<b>Lock no. as per customer request</b> For cylinder lock (longer delivery time) Addtl. charge per lock Order no. ...-...99 & addtl. charge on request
Padlock, brass version, 2 keys	Safety lock made of brass, precision cylinder, 2 keys	BURG number CODE-lock with hardened steel shackle	
Up to 300	Up to 168,000	With 4-digit combination	
0002-10	0002-11	00002-14	

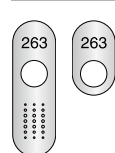

Number plates  
In lock area, self-adhesive, loose for easy attachment, suitable for cylinder locks only  
**Please specify numbers**

With integrated door protection, 123 x 39 x 1.0 mm

Plastic

4902-0601

Stainless steel

4901-0601

Without integrated door protection, 68 x 39 x 1.0 mm

Plastic

4902-0611

Stainless steel

4901-0611

Stainless steel number plate self-adhesive, 30 x 50 x 1.0 mm

**263**

Stainless steel

8501-06

Price



**+** SAFE-O-MAT locks

To overview → p. 219



**+** Additional door protection/number plate

\*Considerably longer delivery time, brass key

! All dimensions in mm, and all prices in Euros



# Electronic locking systems



Locking systems →

C+P has outfitted many lockers with electronic GANTNER locking systems. Just ask us—we'd be happy to advise you!

**Modern locker locking systems from GANTNER**

The requirements on modern lockers and security compartments are very clear: They have to be easy to manage, straightforward in operation and, above all, secure. Each and every GANTNER solution boasts these features.

The identification—and therefore operation—of GANTNER locks occurs in an intuitive and convenient way using a contactless data carrier (chip) integrated into a card, a wristband, a key ring or a watch. Alternatively, the lockers can be operated with a smartphone app.

Locker locking systems from GANTNER can be perfectly integrated into holistic solutions. Using the same contactless data carrier, a unique customer experience is created throughout the entire system— from the ticketing

web shop to the access solution at the entrance through to the cashless payment solution.

The product portfolio includes centrally powered systems with a power pack operated and managed using locker management software. Alternatively, battery-powered locker locks enabling especially easy retrofitting are available. What they all have in common is easy operation and flexible use for all types of cabinets, lockers, rental & security compartments and for frequently changing users and personally assigned lockers.

**GAT NET.Lock**

- + Operation with a chip card, key ring or wristband
- + Management and control using the eLoxx Suite software (on premise, cloud or embedded)
- + Automatic opening of all lockers
- + Alarm in case of break-in attempts
- + Statistical evaluations easy to create
- + Status overview of all lockers on a computer, incl. utilization overview
- + Authorization can be defined for one or more people for each locker
- + Intuitive operation—unique LED status indication
- + Automatic self-calibration and large reader range
- + No maintenance costs
- + Emergency mode in case of loss of service
- + High quality and long service life



Wired GAT NET.Lock locker lock

**GAT ECO.Lock**

- + Locker operated with chip card, key ring or wristband
- + No wiring required
- + Easy retrofitting of existing lockers
- + Intuitive operation
- + Can be integrated into access systems
- + Authorization can be defined for one or more people for each locker
- + Free locker selection or personalized locker assignment
- + High quality and long service life (including the batteries)
- + Clear and unambiguous status indication on the locker
- + Battery-operated and wired locks can be combined
- + Minimal maintenance costs



Battery-operated GAT ECO.Lock locker lock

**GAT ECO.Side Lock**

- + Low-power technology from GANTNER ensures around 10 years of use before a battery change is necessary
- + Audible and visual alarm functions on the locker
- + Locker aesthetic isn't disrupted thanks to fully internal installation
- + Protected against vandalism (no external parts)
- + Intuitive one-handed operation
- + Easy installation, no wiring—suitable for all locker materials
- + Large variety of operating modes—free locker selection, personal locker or time-limited locker
- + Multiple master keys



Battery-operated GAT ECO. locker lock Side lock

**GT7 terminal**

- + Universal terminal with different apps for different applications
- + Rugged hardware with touch display and integrated RFID reader
- + Flush-mounted and surface-mounted variants available
- + Different interfaces for flexible integration into an overall system
- + Info app: Read the locker number from the data carrier
- + Access app: Available for access control
- + G7 Connect service: Cloud-based commissioning and backup (for even greater security)



GT7 terminal with info app



# Locking systems:

## Examples of many different options.

### Electronic PIN code lock 3780

Whether for free locker selection or for permanently assigned security compartments and lockers, the 3780 is the perfect solution whenever the use of keys for locker locking is not desired.

Instead of a key, a 4-digit numerical code ensures secure locking and unlocking of the locker or security compartment. In a nutshell, the Euro-Locks PIN code lock stands out thanks to its:

- + Ease of use
- + Fast installation
- + Compatibility with the most common standard hole patterns for cylinder locks
- + Ease of operation and code setting
- + Immediate readiness for operation
- + Emergency opening using master key function in case of battery failure

Should battery replacement be forgotten and the battery die (but the locker compartment needs to be opened), the lock can be opened mechanically with the integrated lock cylinder with a master key, preventing the need for destructive opening.



Available in the colors silver and black



### All the advantages at a glance

- + Private, public and technical mode
- + Operated with 2 type AA batteries
- + 4-digit user code
- + 6-digit master code, 6-digit technical code
- + Up to 80,000 tested locking cycles with one set of batteries
- + Battery status warning via LED
- + Master key (optional)
- + Audible signal (switchable)
- + Function display via LED
- + Sturdy die-cast zinc housing and handle

**Note:**

If you are buying locks at a later stage, we always need you to provide the original order and the locker type.

C+P has outfitted many lockers with electronic locking systems. Just ask us—we'd be happy to advise you!

## Mechanical combination lock WF 1401



The mechanical WF combination locks are characterized by easy operation and a rugged and functional design—they're the affordable alternative to electronic PIN locks.

- + Maintenance-free, as they're purely mechanical; 10,000 freely programmable user codes
- + Lock cylinders for service key (for resetting and emergency opening)
- + For the WF 1401 for permanent users, the code is automatically obscured after each use but remains stored
- + For the WF 2112 for changing users, the code is reset before each use and manually obscured by the user



## Mechanical coin-operated deposit lock 1606

The first coin-operated deposit lock which can be used as a real lever lock with nearly all steel lockers or retrofitted. Its compact size offers considerable space and cost advantages over conventional coin-operated deposit locks when used on smaller compartments.

- + Maintenance-free, as it's purely mechanical
- + Master key-compatible
- + Convenient front operation, self-explanatory design, no instructions required
- + Practical reversible key with pleasant large grip area
- + Lock cylinder with centering as insertion aid, also easy to operate by persons with disabilities
- + Rugged design and compact, round shape means essentially no attackable surface for the use of force or vandalism
- + Theft-proof storage of the coin while locked thanks to two powerful metal claws
- + Available for 1 Euro coins as standard, various other currencies available on request



## Electronic PIN code lock 1904



PIN code lock 1904 is a battery-operated, self-contained and standalone lever lock.

The electronics offer numerous settable functions and operating modes. Operation and programming are supported by visual and audible signals.

- + Flexibly settable for permanent or changing users, freely selectable master and user codes, in-use indication and battery warning
- + AUTO-OPEN TIMER (automatic door opening at a settable point in time) in public mode
- + Lock cylinder for service key for emergency opening and more:
- + Operating section, incl. battery, removable without tools using service key without opening the locker door—for convenient programming and battery changing at any location (practical with low compartments, for example)
- + Battery change possible without losing any codes or settings
- + Depending on the operating mode, up to 100,000 locking cycles with a single commonly available 1.5 V AA alkaline battery

## Electronic RFID lock 1905

The RFID lock 1905 is a battery-operated and self-contained system which works only with WF-certified and -initialized transponders (13.56 MHz Mifare Ultralight). This makes it the first choice for use wherever locks and transponders are to harmonize with one another perfectly and flawlessly.

Cards, key rings or wristbands can be used as the transponder.

- + Dimensions, battery access, bolt, service key and mechanical design are identical to PIN code lock 1904
- + Large number of settable functions and operating modes for permanent and changing users (private/public)
- + AUTO-OPEN TIMER (automatic door opening at a settable point in time) in public mode
- + Read/write system where information can also be transferred from the lock to the transponder
- + Easy programming using accompanying transponder with NFC-compatible smartphone and free app



- + In-use indication in public mode: Only a single transponder can be programmed per lock
- + In private mode, up to 8 transponders can be taught in and withdrawn again per lock
- + Information such as locker and compartment numbers can be read out by authorized persons if necessary
- + Depending on the operating mode, up to 80,000 locking cycles with a single commonly available 1.5 V AA alkaline battery

All locks are innovative German-made products suitable for indoor use only.

## Combined RFID and PIN code lock SAFE-O-TRONIC® access LS

SAFE-O-TRONIC® access replaces the conventional cylinder lever locks with electronic locking convenience. This finally makes cumbersome key management a thing of the past. PIN code and RFID technologies are combined in a unique way.



### Keyless with a PIN code

The personal PIN code can be conveniently entered through a light touch of the key pad. Programming the locking system with master codes is also possible using an RFID card to save time.



### Contactless with an RFID card

For use with RFID data carriers (e.g. card, wristband or key ring)—just hold the data carrier in front of the reader. All RFID technologies as per ISO 14443 A (e.g. MIFARE®) are available.



SAFE-O-TRONIC®  
access LS 101  
PIN code lock

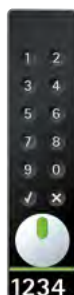

SAFE-O-TRONIC®  
access LS 200  
PIN code lock  
with RFID programming  
and RFID master  
function



SAFE-O-TRONIC®  
access LS 300  
RFID lock



SAFE-O-TRONIC®  
access LS 400  
combined RFID  
and PIN code lock

## All the advantages at a glance:

- + **Easily adapt standards**  
Locker doors prepared for the usual standard lever cylinder can very easily be outfitted or retrofitted with SAFE-O-TRONIC® access. This saves both time and money at the time of installation.
- + **Flexible management**  
Different user groups can be organized extremely easily with a PIN code (e.g. daily visitors) or RFID chip card (e.g. club members, and personnel).
- + **Convenient operation**  
A light touch of the keypad (capacitive technology) is all that's required to enter a personal PIN code. RFID data carriers are simply held in front of the reader for identification. The keyboard won't wear down and facilitates use in wet rooms like swimming pools and sauna areas.
- + **Locker capacity optimization**  
Large variety of functions for protection against compartment reservation optimize your locker capacity. Among other things, this allows you to program your lockers in a way that locks or unlocks them automatically at a predetermined point in time (e.g. automatic nighttime opening).
- + **Controlled opening**  
Should it be necessary for the personnel to open a locker, master locking which only allows opening—and not uncontrolled re-closing—is available in addition to conventional master locking. This way, you increase security for your visitors and protect your personnel from false suspicion.
- + **Organize offline locking systems online**  
The card-based network SAFE-O-TRONIC® CyberNet offers online convenience for offline locking systems.
- + **Time-saving programming**  
Your locking system can be programmed in a flash thanks to SystemKeys.
- + **Convenient monitoring options**  
For monitoring purposes, all locking processes can be logged, printed, analyzed and verified beyond a doubt.
- + **Universal applications**  
The slim SAFE-O-TRONIC® access LS designer lock is suitable for locker doors on the left and right as well as doors in special shapes.
- + **Custom design**  
From locker numbering to logos, SAFE-O-TRONIC® access makes your custom design ideas a reality.

Please send us your project-specific request.



## Coin-operated locks

C + P offers locking systems of the SAFE-O-MAT brand for its assembled box and changing room lockers. Lockers with these locking systems are suitable for use at public facilities and institutions such as swimming pools, sports facilities, schools, universities, fitness and recreation centers as well as at shopping malls, trade shows, libraries and hospitals. SAFE-O-MAT systems are available in different variants:

The **2-coin slot models** are available as both a deposit lock and as a combined deposit/token-operated lock.

- + The **twin-coin deposit lock** enables the user to choose between two different coins for use in the coin slot. This prevents operators and users alike from having to change coins.
- + With the **twin-coin multi-use combined deposit/token-operated lock**, a visitor can insert a deposit coin which is returned to them after using the locker, in addition to a coin paid as a fee. This enables the visitor to come back and use "their" compartment as often as they'd like, free of charge. The inserted deposit coin also protects against key theft.
- + The **deposit/token-operated lock** is also optionally available for other coin combinations.

### Functioning of the locking systems

Prior to use, the key is firmly lodged in the lock and the locker door is open.

After the required coin(s) or token is/are inserted, the door can be closed and the key removed. Clothing and valuables are securely stored. The user holds on to the key.

As soon as the user re-opens the locker, the coin/token drops into the collecting tray. The key is again firmly lodged in the lock, making the locker available for the next visitor right away.

### Practical key logistics

Key wristband sets and identical numbering on the locker and wristband (available upgrades) ensure practical use. Thanks to keys with clip-in number plates, the locking system can be organized very easily and conveniently. The number plates can be clipped into the key head by the operator themselves at any time—in seconds and without any tools. This eliminates the need for elaborate stamping and fastening. At the same time, it ensures greater flexibility and saves time when numbering and allocating the user keys. The fully laser-marked number plates can be stored on site in sets of 50.



Twin-coin deposit lock

### Additional security

The SAFE-O-MAT locking system has an exchangeable cylinder system as standard. By means of an emergency opening key, it allows for emergency openings (if keys are lost) through controllable cylinder replacement. Visitors who have lost their key can receive help immediately. The lost key doesn't pose a threat to security, as the replaced lock cylinder ensures that the key no longer fits the lock.

Special benefit of this solution: Quick cylinder replacement after any key loss means there's no need to buy several spare keys for every lock. This also eliminates any associated security risk. One or two replacement cylinders are all you need! In addition, there are no risks associated with the traditional master key system where the loss of the master key can jeopardize the security of the entire locking system.

However, a conventional master key can be provided on request in order to, for instance, take the deposit coin as a "fine" for the unauthorized reservation of a compartment. Let us help you with your individual needs.

## The advantages of coin-operated locks at a glance:

- + **Lower operating costs**  
No need for staff members to give out and take back keys.
- + **Protection against key loss**  
The locker key is held in the lock until the locker is in use. Even after the locker is opened, the key is automatically lodged in position and cannot be removed accidentally.
- + **Time savings for the user**  
No long wait for keys to be issued.
- + **Better utilization of locker capacity**  
The locker can be used by different visitors several times a day.



Twin-coin multi-use token-operated lock

## Key head and wristband versions

As standard, SAFE-O-MAT locks are supplied with a **standard key head**. Wristband set 1, which is also standard, also fits this, where the wristband is inserted crosswise through the key:



On request, the **ball holder key head** and matching wristband set 1 can also be provided. This features a key protection pouch in which the key can be held parallel to the wristband.



The **ball ring key head** is also available on request. This is not suitable for wristbands, but only for number tags with a key ring.



**Prior to ordering, please choose** the variant you need, as different versions **cannot be retrofitted!**



# Benches and benches with coat rack

Sturdy and flexible in use.



## Stackable benches, series 855

### The stackable benches

- + Sturdy round tube steel frame construction with high-quality enamel coating
- + Seat section made of solid beech wood slats coated with clear varnish
- + Benches can be stacked
- + Plastic floor gliders
- + Delivered fully assembled



## BASIC benches and benches with coat rack

### The tried and tested benches with wood and plastic slats

- + Sturdy steel square tube construction with high-quality enamel coating
- + Seats, backrests and hook rails made of rounded hardwood slats, with clear varnish
- + Alternative plastic bench slats with steel core
- + Adjustable floor gliders for easy level adjustment (10 mm)
- + Hook rails with plastic double clothes hooks, concealed according to DIN 7917
- + Delivered preassembled for immediate use
- + Optional shoe rack, can also be retrofitted



To the products →



## COMFORT benches and benches with coat rack

### The wet room benches with HPL seats

- + Sturdy square profile structure made of steel
- + **Frames and shoe racks electrolytically zinc plated as standard** and with high-quality enamel coating
- + Seats, backrests and hook rails made of solid-core top (HPL, 13 mm thick) with decor surface
- + Adjustable floor gliders for easy level adjustment (10 mm)
- + Hook rails with plastic double clothes hooks, concealed according to DIN 7917
- + Delivered preassembled for immediate use
- + Optional shoe rack, can also be retrofitted



Classic PLUS project solutions → p. 60



EvoLO PLUS project solutions → p. 98



Wall-mounted and free-standing wardrobes → p. 234

# Series 855 stackable benches





Order no. 3x8552-000

## Features of stackable benches of the 855 series:

- + Sturdy construction
- + Feet made of 25 mm round tube steel frame, powder coated in RAL 7021 black gray
- + Seat section made of three 80x20 mm solid beech wood slats coated with clear varnish
- + Seat depth: 300 mm, seat height: 460 mm
- + Benches can be stacked
- + Black abrasion-resistant plastic floor gliders
- + Delivered fully assembled

## Dimensions and design

Dimensions and design				
Height: 460	Width	1200	1600	2000
Depth: 460	Order no.	8550-000	8551-000	8552-000
	Price			



Order no. 8550-000



Order no. 8551-000



Order no. 8552-000



# Basic benches and benches with coat rack

## Features of BASIC benches and benches with coat rack:

- + Sturdy steel square tube construction, 30x30 mm, with high-quality enamel coating
- + Seats, backrests and hook rails made of beech hardwood slats rounded and planed on all sides, 60x25 mm profile, coated with clear varnish, with natural color differences
- + Alternative plastic bench slats with steel core available for all models at no additional charge
- + Adjustable floor gliders for easy level adjustment (10 mm)
- + Hook rails with plastic double clothes hooks, concealed according to DIN 7917
- + Delivered preassembled for immediate use
- + Optional shoe rack, can also be retrofitted
- + Standard frame color black gray RAL 7021



Order no. 8052-000



Order no. 8051-010  
& plastic bench slats 8000-9010

## Dimensions and design

### Free-standing bench

Frame in black gray RAL 7021 (standard)

Height: 420

Depth: 353



Without shoe rack



With shoe rack

Width

Feet

Order no.

Price

1000

4

8050-000

1500

4

8051-000

1960

6

8052-000

Order no.

Price

8050-010

8051-010

8052-010

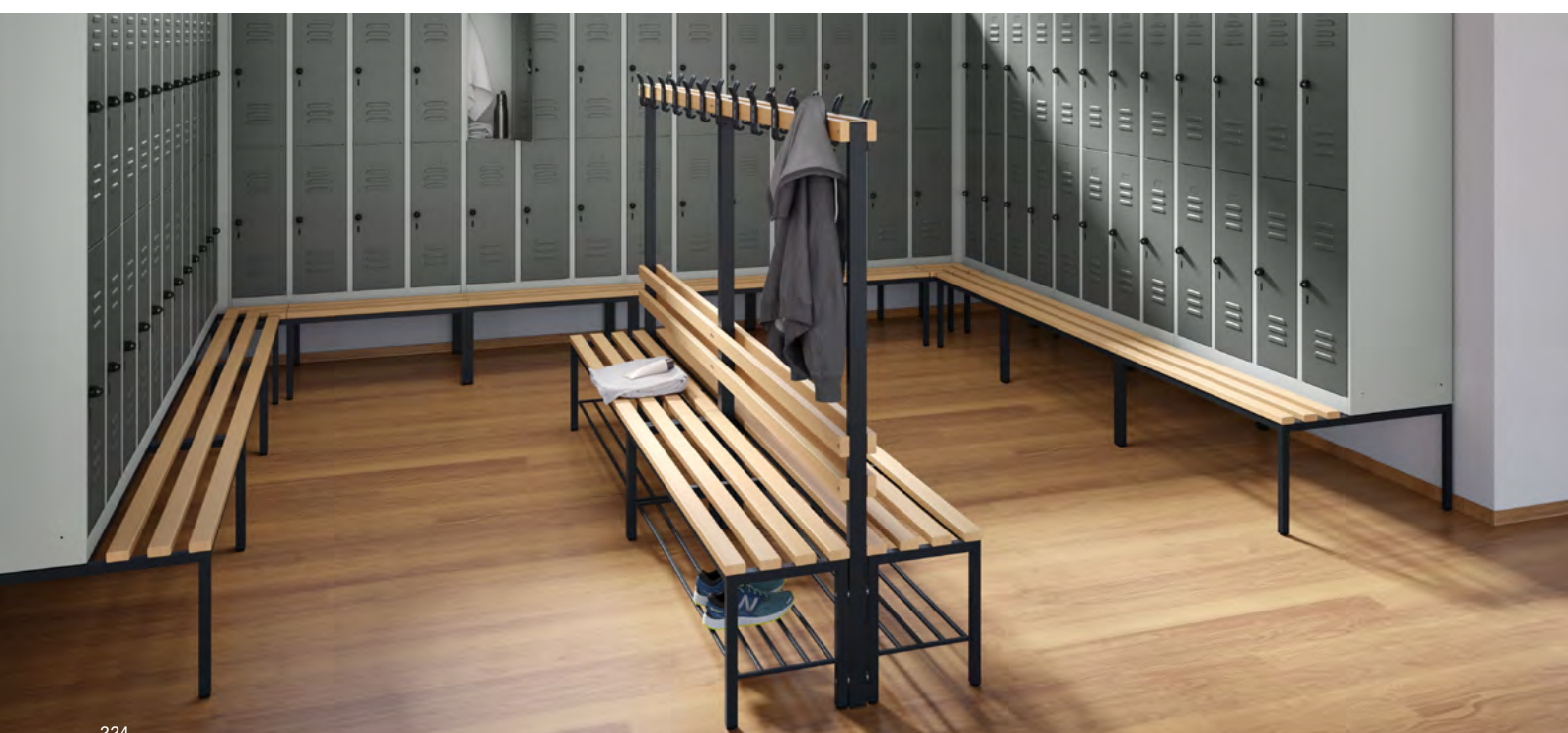

# Accessories



Order no. 8078-2101

## Wall-mounted wardrobe

Hook rail for wall mounting with plastic double hooks, incl. 20 mm wall spacer

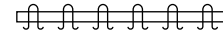
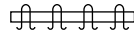

Width	996	1496
Double hooks	4	6
Depth	68	68
Order no.	8078-2101	8078-2111
Price		



## Comfort coat hooks

Additional functions

- + Combined hat and double coat hook
  - + Customizable number plate (with individual motifs, numbering etc.)
  - + Coat hook bent backward (concealed according to DIN 7917)
- Featuring a modern design, made of high-quality plastic.



## Shoe racks

With 5 crossbars made of square profile, one-sided. For retroactive mounting in benches without shoe racks (double-sided benches require a shoe rack on each side).

Width	1000	1500	1960
Order no.	8050-7100	8051-7100	8052-7100
Addtl. charge			



## + Plastic bench slats with steel core

	Light gray	White	Black gray
& order no.	+ 8000-7035	+ 8000-9010	+ 8000-7021
& addtl. charge			

# Basic one-sided and double-sided benches with coat rack



Order no. 8051-110

## Dimensions and design

**One-sided bench with coat rack**  
Frame in black gray  
RAL 7021 (standard)

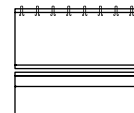
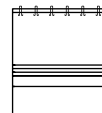
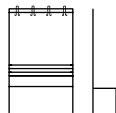

Height: 1,710  
Seat height: 420

Width	1000	1500	1960
Depth	403	403	403
Feet	4	4	6
Double hooks	4	6	8
Order no.	8050-100	8051-100	8052-100
Price			



Order no.	8050-110	8051-110	8052-110
Price			



Comfort coat hooks with exchangeable individual label



Floor gliders with 10 mm level adjustment





Company

Color concept

Changing room & wardrobe

Workshop & factory

Office & archive

**Double-sided bench with coat rack**  
Frame in black gray RAL 7021 (standard)

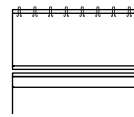
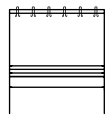
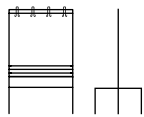

Width	1000	1500	1960
Depth	756	756	756
Feet	2x4	2x4	2x6
Double hooks	2x4	2x6	2x8
Order no.	8050-200	8051-200	8052-200
Price			
Order no.	8050-210	8051-210	8052-210
Price			



Order no. 8050-200  
& plastic bench slats 8000-7021



# Comfort benches and benches with coat rack

## Features of COMFORT wet room benches with HPL seats:

- + Sturdy square profile construction, 30x30 mm, made of steel
- + Frames and shoe racks **electrolytically zinc plated** as standard and with high-quality enamel coating
- + Seats, backrests and hook rails made of solid-core top (HPL, 13 mm thick) with decor surface
- + Adjustable floor gliders for easy level adjustment (10 mm)
- + Hook rails with plastic double clothes hooks, concealed according to DIN 7917
- + Delivered preassembled for immediate use
- + Optional shoe rack, can also be retrofitted
- + Standard frame color: black gray RAL 7021



## Dimensions and design

### Free-standing bench

Frame in black gray RAL 7021 (standard)

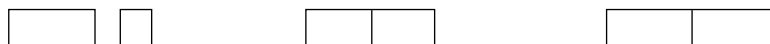

Height: 401	Width	1000	1500	1960
Depth: 353	Feet	4	4	6
Seat height: 401				

 Without shoe rack	Order no.	8060-000	8061-000	8062-000
	Price			

 With shoe rack	Order no.	8060-010	8061-010	8062-010
	Price			

### Free-standing bench with backrest

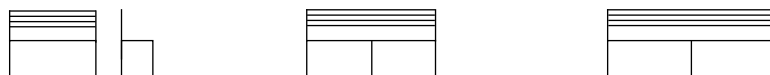

Height: 796	Width	1000	1500	1960
Depth: 407	Feet	4	4	6
Seat height: 401				

 Without shoe rack	Order no.	8060-300	8061-300	8062-300
	Price			

 With shoe rack	Order no.	8060-310	8061-310	8062-310
	Price			



Company

Color concept

Changing room & wardrobe

Workshop & factory

Office & archive

## Dimensions and design

### Double-sided bench with backrest

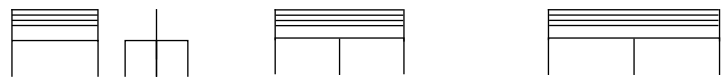

Height: 796  
Depth: 760  
Seat height: 401

Width	1000	1500	1960
Feet	4	4	6



Order no.	8060-400	8061-400	8062-400
Price			



Order no.	8060-410	8061-410	8062-410
Price			



Order no. 8062-110





Order no. 8060-210

## Dimensions and design

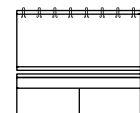
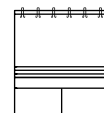
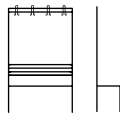
**One-sided bench with coat rack**  
Frame in black gray RAL 7021 (standard)





Height: 1,710	Width	1000	1500	1960
Depth: 407	Feet	4	4	6
Seat height: 401	Double hooks	4	6	8
	Order no.	8060-100	8061-100	8062-100
	Price			

	Order no.	8060-110	8061-110	8062-110
	Price			

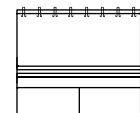
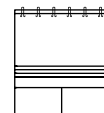
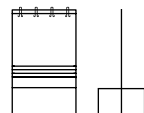
**Double-sided bench with coat rack**  
Frame in black gray RAL 7021 (standard)



Height: 1,710	Width	1000	1500	1960
Depth: 760	Feet	2 x 4	2 x 4	2 x 6
Seat height: 401	Double hooks	2 x 4	2 x 6	2 x 8
	Order no.	8060-200	8061-200	8062-200
	Price			

	Order no.	8060-210	8061-210	8062-210
	Price			

# Accessories & decors



Order no. 8078-4101

## Wall-mounted wardrobe

Hook rail for wall mounting with plastic double hooks, incl. 20 mm wall spacer

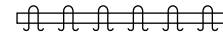
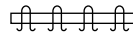

Width	996	1496
Depth	68	68
Double hooks	4	6
Order no.	8078-4101	8078-4111
Unit price		



## Comfort coat hooks

- + Combined hat and double coat hook
- + Customizable number plate (with individual motifs, numbering etc.)
- + Coat hook bent backward (concealed according to DIN 7917)



## Shoe racks

With 5 crossbars made of square profile, for retroactive mounting in benches without a shoe rack electrolytically zinc plated and with enamel coating, RAL 7021 black gray

Width	1000	1500	1960
Order no.	8060-7100	8061-7100	8062-7100
Price			



Seats, backrests and hook rails made of high-pressure laminate/HPL, 13 mm thick, with decor surface



Floor gliders with 10 mm level adjustment

+ HPL decors

Selection → p. 53



# Something for everyone

## Open wardrobe systems.



### Wall-mounted and free-standing wardrobes

#### The useful helpers for the lobby

- + Sturdy steel and aluminum construction
- + Functional and adaptable design
- + Intermediate sizes in 100 mm increments also possible
- + Free-standing wardrobes optionally available with casters for mobile use (on request)
- + Optional double numbering for use as a “theater wardrobe”
- + Two umbrella stand variants
- + Delivered disassembled with easy assembly instructions

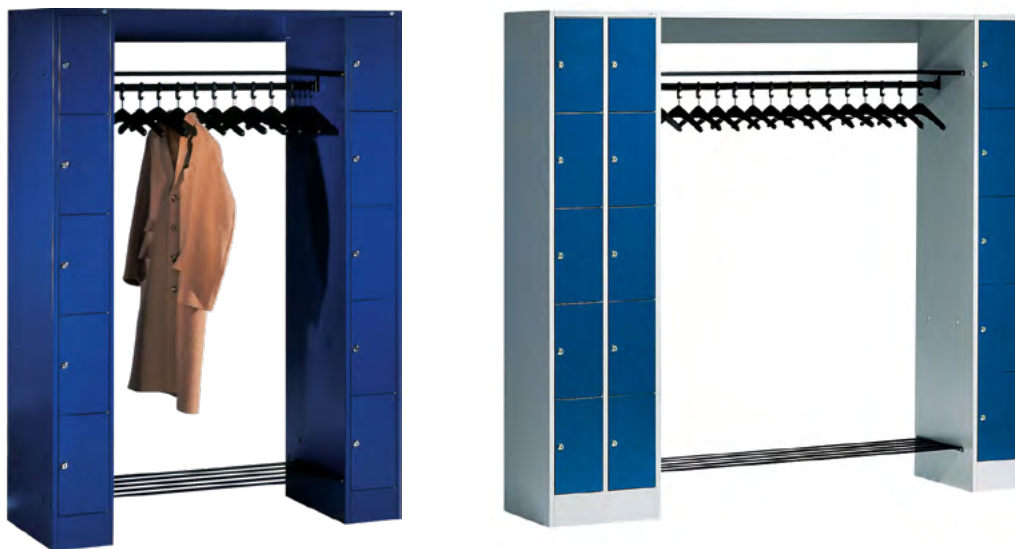

## Open wardrobes and assembled box lockers

### The classic office wardrobe designed for continuous connection

- + Sturdy steel construction with high-quality enamel coating
- + 2 box widths (wide version suitable for motorcycle helmets)
- + Flexible continuous system comprising assembled box lockers, intermediate parts and end panels, expandable at any time
- + 90° door opening limiter as standard
- + Coat hangers feature special mounting (discourages theft)
- + Double-walled doors with cylinder lock and 2 keys

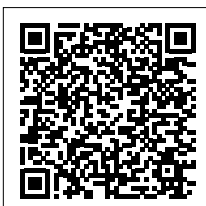

To the products →

# Wall-mounted and free-standing wardrobes

Features of wall-mounted and free standing wardrobes:

**Wall-mounted wardrobes A and B:**

- + Cross profile and hook rail made of silver-colored anodized aluminum
- + Model B side profiles made of steel, silver-metallic coated (textured paint)

**Wall-mounted and free-standing wardrobes C through G:**

- + All silver-colored profiles made of anodized aluminum
- + All dark profiles and frames made of steel, coated dark gray (textured paint)
- + All clothes hooks and coat hangers made of plastic, dark gray
- + Delivered disassembled with easy assembly instructions
- + **Wall-mounted wardrobes C and D sized 400 mm to 3,000 mm wide available in 100 mm increments—just ask us!**



## Dimensions and version

**Wall-mounted wardrobes**



(A)



(B)



(C)



(D)

Height	80	160
Width	1000	1000
Depth	80	330
Number of hooks	10	19
Number of coat hangers	-	-
Order no.	99004-000064	99004-000063

Height	160	300
Width	1000	1000
Depth	150	540
Number of hooks	10	-
Number of coat hangers	-	10
Order no.	99004-000039	99004-000012

Price

- + **Replacement coat hangers** for wardrobes D and G, made of dark gray plastic, self-aligning

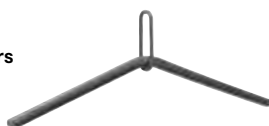

Order no.	99004-000060
-----------	--------------

Price

- + **Numbering** For all free-standing wardrobes with hooks, consisting of self-adhesive number plates and matching wardrobe tag, both black plastic with white numbering (please specify).

**Plastic number plate**  
29x24 mm, self-adhesive, numbers 1 through 999 possible

Order no.	99004-000061
-----------	--------------

Price

**Plastic issue number**  
65x32 mm, can have same number as number plate

Order no.	99004-000062
-----------	--------------

Price



One-sided wardrobe with 19 hooks



Ⓔ

Double-sided wardrobe with 38 hooks



Ⓕ

One-sided wardrobes with 10 coat hangers



Ⓖ

### Dimensions and version

#### Free-standing wardrobes

Height	1700	1700	1700
Width	1000	1000	1000
Depth	410	600	600
Number of hooks	19	38	-
Number of coat hangers	-	-	10
Order no.	99004-000001	99004-000002	99004-000003
Price			

### Umbrella stands with drip pan

Silver-colored profiles made of anodized aluminum, dark profiles made of steel, coated dark gray (textured paint). Drip pan coated with rubber.



Height: 530	Width	700	1000
Depth: 220	Description	For 5 umbrellas	For 7 umbrellas
	Order no.	99004-000004	99004-000005
	Price		



# 8070 series

## Open wardrobes.



90° door opening limiter



Wide box (e.g. for motorcycle helmets) from model 82700



Order no. 80700-00



Order no. 80710-00

### Dimensions and versions



#### Open wardrobes

Height: 1,950  
Depth: 480

	Width	740	960	1430	1870
Description		1 locker with 5 boxes, no. 80700-10, 1 top shelf, 1 hat rack with 5 coat hangers, 1 shoe rack, 1 end side panel	1 locker with 5 boxes, no. 82700-10, double-width, 1 top shelf, 1 hat rack with 5 coat hangers, 1 shoe rack, 1 end side panel	2 lockers with 5 boxes each, no. 80700-10, 1 top shelf, 1 hat rack with 10 coat hangers, 1 shoe rack	2 lockers with 5 boxes each, no. 82700-10, double-width, 1 top shelf, 1 hat rack with 10 coat hangers, 1 shoe rack
For no. of persons		5	5	10	10
Clear opening dimensions per box HxWxD		345x190x460	345x410x460	345x190x460	345x410x460
Order no.		80700-00	82700-00	80710-00	82710-00
Price					

→ Body and door color

Color concept → p. 48

## Features of the 8070 series:

- + Sturdy steel construction with high-quality enamel coating
- + Expandable and modifiable continuous system
- + Double-walled hinged doors
- + All doors with 90° door opening limiter
- + Cylinder lock with 2 keys
- + Two box sizes
- + Lockers prepared for intermediate parts on left and right
- + Coat hangers feature special mounting (discourages theft)
- + Hat rack and shoe rack made of square tube, coated in black gray, base in body color
- + The wardrobes are delivered disassembled with easy assembly instructions
- + Asymmetrical wardrobes can also be assembled mirrored



Order no. 80730-00



Order no. 80730-20

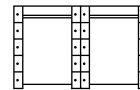
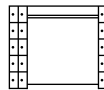

954

2 end panels,  
no. 8074-00,  
1 top shelf,  
1 hat rack with  
10 coat hangers,  
1 shoe rack,  
1 rear panel, no. 8071-02

10

-

8071-03

1410

1 locker with 10 boxes,  
no. 80700-20,  
1 top shelf,  
1 hat rack with  
10 coat hangers,  
1 shoe rack,  
1 end side panel

10

345x190x460

80720-00

2100

1 locker with 10 boxes,  
no. 80700-20,  
1 locker with 5 boxes,  
no. 80700-10  
1 top shelf,  
1 hat rack with 15 coat hangers,  
1 shoe rack

15

345x190x460

80730-00

2840

2 lockers with 5 boxes each,  
no. 80700-10,  
1 locker with 10 boxes,  
no. 80700-20,  
2 top shelves,  
2 hat racks with 10 coat hangers each,  
2 shoe racks

20

345x190x460

80730-20

# Accessories for open wardrobe systems

## Intermediate parts

Width	500	950	1400
Depth	480	480	480
	1 top shelf, 1 hat rack with <b>5</b> coat hangers, 1 shoe rack <b>for no. 80700-00 and 82700-00</b>	1 top shelf, 1 hat rack with <b>10</b> coat hangers, 1 shoe rack <b>for no. 80710, 80720, 8270-00 and 80730-20</b>	1 top shelf, 1 hat rack with <b>15</b> coat hangers, 1 shoe rack <b>for no. 80730-00</b>
Order no.	8070-01	8071-01	8073-01
Price			

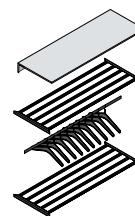

## Rear panels

Height: 1,950



Width	500	950	1400
Order no.	8070-02	8071-02	8073-02
Price			

## Side end panel

Height: 1,950 mm  
Depth: 480 mm



Width	20
Order no.	8074-00
Price	



## Door reduced in size

For letter drop for 80700/82700 series  
(addtl. charge per door/longer delivery time possible)

Order no.	8000-25
Price	



Double coat hooks for ease of use,  
with integrated mounting for coat hangers

## Coat hangers

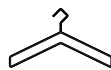

	<b>Standard</b> Hardwood in black paint finish (with special mounting)	<b>Stainless steel</b> (with conventional mounting)
Order no.	8000-061	8000-063
Price		

# 8070 series

## Assembled box lockers.



Order no. 80700-40



Order no. 82700-20

### Dimensions and design



Height: 1,950	Width	240	460	680	900	460	900
Depth: 480	Description	With 5 box tiers	With 5 box tiers and 2 adjacent boxes = 10 boxes	With 5 box tiers and 3 adjacent boxes = 15 boxes	With 5 box tiers and 4 adjacent boxes = 20 boxes	With 5 box tiers (double-width)	With 5 box tiers and 2 adjacent boxes (double-width) = 10 boxes
	Clear opening dimensions per box H x W x D	345 x 190 x 460	345 x 190 x 460	345 x 190 x 460	345 x 190 x 460	345 x 410 x 460	345 x 410 x 460
	Order no.	80700-10	80700-20	80700-30	80700-40	82700-10	82700-20
	Price						

→ **Body and door color**





Color concept → p. 48





# 8070 series

## Accessories for assembled box lockers.

### Cylinder locks and turning bolt latch

Prices per lock	Basic version	Optional			Turning bolt latch
	Cylinder lock	Cylinder lock in black with 2 keys			
					
	Up to 1,000 different key numbers	Up to 6,000 different key numbers	Via master key system with security certificate	Via master key system without security certificate	For padlock
Order no.	8077-30	8077-300	8000-01	8000-001	0003-00
Price					

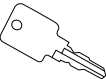
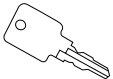
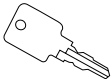
### Keys and wristband for cylinder locks

						
	<b>Spare key for cylinder lock</b>	<b>Spare key for master key system</b>		<b>Master key for master key system</b>		<b>Perlon wristband for cylinder keys</b>
	Spare key for lock 8077-30/8077-300	<b>With</b> security certificate*	<b>Without</b> security certificate*	<b>With</b> security certificate*	<b>Without</b> security certificate	<b>Color: 51 black;</b> other colors no addtl. charge, <b>change color no.</b> at end of order no.: 51 black, 52 white, 53 red, 55 blue, 61 green, 67 yellow
Order no.	0006-00	0010-11	0006-00	0011-00	0012-00	Please specify desired numbers! 8501-0551
Price						

\*Considerably longer delivery time, brass key

+ SAFE-O-MAT locks

Selection → p. 219



## Padlocks

For turning bolt latch,  
bolt size: approx. 6 mm



Brass version,  
2 keys, up to 300  
different key numbers

Brand name lock, brass  
version with precision  
pin cylinder, 2 keys, up to  
168,000 different key numbers

BURG number CODE lock  
with hardened steel shackle,  
with 4-digit combination

Order no.

0002-10

0002-11

00002-14

Price

## Number plates

Please specify numbers

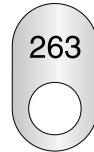
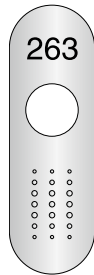

Number plates in lock area, self-adhesive, loose for easy attachment,  
suitable for cylinder locks only

Stainless steel  
number plate,  
self-adhesive,  
30 x 50 x 1.0 mm

With integrated door protection,  
123 x 39 x 1.0 mm

Without integrated door protection,  
68 x 39 x 1.0 mm

Version

Plastic

Stainless steel

Plastic

Stainless steel

Stainless steel

Order no.

4902-0601

4901-0601

4902-0611

4901-0611

8501-06

Price

## Lock no. as per customer request

Additional charge per lock

For cylinder lock  
(longer delivery time)

Order no.

...-...99

& addtl. charge On request



+ Additional door protection/  
number plates



# Industry-specific and custom solutions



## Fire service lockers

### The professionals for professionals

- + Complete range for all fire service applications—developed in practice, for use in practice
- + Sturdy steel construction with high-quality enamel coating
- + All locker bottoms are zinc-plated for optimum corrosion protection as standard
- + Optional folding C + P helmet holder with effective ventilation function, suitable for all common EU helmet manufacturers and sizes without adjustment.
- + Various compartment widths and versions available
- + All lockers can be combined with one another
- + Large selection of practice-oriented accessories
- + Available floor-standing, wall-mounted, with feet or with base



## Laundry collection and dispensing lockers

### The well thought-out dispensing and collecting lockers

- + Sturdy steel construction with high-quality enamel coating
- + Dispensing lockers with two different box sizes
- + Practical central door for collective loading and individual unloading
- + Either feet or base as sub-frame
- + Collection lockers with integrated swing flap
- + Laundry-bag holder



## Laptop lockers

### The secure computer garage

- + Sturdy steel construction with high-quality enamel coating
- + The solution for secure and space-saving storage of 10 or 20 laptops, notebooks or tablets
- + Optionally available with power connection in each box (sockets always installed on left, locker connection cable included)
- + Doors hinged on the right, with sturdy swivel rod hinge
- + One cylinder lock with 2 keys for each door



## Loading assembled box lockers

**The spacious loading aid with 2 sockets per box**

- + With boxes for the secure and space-saving storage of batteries and other implements
- + With two power connections in each box (230 V sockets)
- + Sturdy steel construction with high-quality enamel coating
- + Doors hinged on the right, with sturdy swivel rod hinge
- + Convenient doorstop silencer for pleasant closing
- + All lockers feature a base
- + Usable box sizes (HxWxD): 375 x 330 x 465



## Small-compartment and safe deposit box lockers

**The specialist lockers**

- + Sturdy steel construction with high-quality enamel coating
- + Safe deposit box lockers with door reduced in size, e.g. for letter drop
- + Small-compartment lockers with two box sizes for easy adaptation to the desired use
- + Attractive locker base in black gray
- + One cylinder lock with 2 keys for each door



## Classic PLUS Compartment width: 250

**The space-savers for tight spaces**

- + Sturdy steel construction with high-quality enamel coating
- + Single- and double-tier versions
- + Break-in-resistant design as per class B according to DIN 4547-2
- + Compartment width: 250 mm
- + Reinforced doors with ventilation gills and stamped-in label holder
- + Safety turning bolt for padlock
- + Compartment bottoms can be swept out easily

**Available floor-standing, with feet or with base**





# The professionals for professionals

## Developed together with fire service professionals for fire service professionals.

**Rescue, extinguish, retrieve and protect: Together with your team, you overcome the biggest challenges day in and day out. This demands 100% professionalism—just like the storage space at your fire station.**

We've developed a series of fire service lockers which cover all your individual needs in a very flexible way. From youth firefighters to volunteers to plant firefighters, all the models have one thing in common— they're extremely rugged, highly functional, comply with all the current guidelines and look really good, too. All C+P fire service lockers can easily be combined with one another. Choose from a variety of equipment options and colors—with us, there are no limits to your dream-locker team.

**For optimum corrosion protection, all locker bottoms are zinc plated as standard.**





Company

Color concept

Changing room & wardrobe



Workshop & factory

Office & archive



# Dirty/clean separation made easy and very flexible

Many fire service stations need to be modernized to guarantee legally required dirty/clean separation and therefore prevent the potential carryover of contamination. This is also one of the key stipulations for new buildings in Part 1 “Planning guidelines” of DIN 14092 “Fire service stations.” C+P fire service lockers can easily be combined with one another. Choose from a variety of equipment options and colors—with us, there are no limits to your dream-locker team.



Fire service lockers from C+P ensure that your personal protective equipment (PPE) and your street clothes are always stored well & securely and guarantee quick drying as well. Thanks to the option to combine all the different models, they can be arranged extremely flexibly in such a way that the storage room solution perfectly suits the individual requirements of your fire station and your team of firefighters. And that goes for colors, too. In addition to the classic “fire red,” a broad range of other colors are available.





# Product features and accessories well thought out in every detail



Folding helmet holder with effective ventilation function, suitable for all common EU helmet manufacturers and sizes without adjustment.

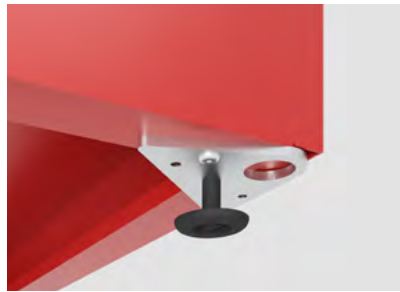

Base level adjustment as standard, optional for feet and floor-standing versions



Special combination lock with code-cover and master key functions for the secure locking of valuable objects and personal items.



For optimal corrosion protection, all locker bottoms and bases are zinc plated as standard, and the locker feet are made of plastic.

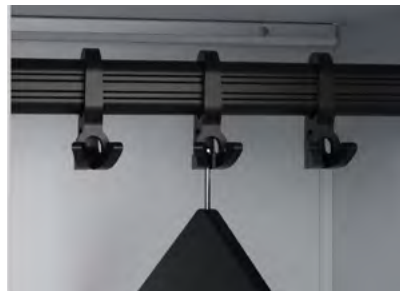

High load-capacity double sliding hooks with hanging option for adjustable partitions or hangers with a "hotel pin"



For the secure storage and quick removal of accessories: side hook rail with high load capacity and stainless steel sliding hooks.

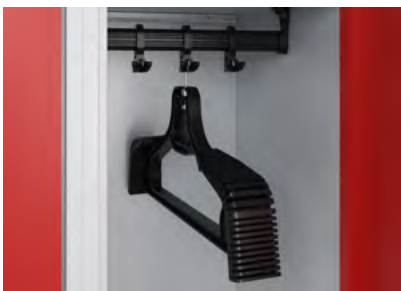

Special drying hanger prevents clothing from being creased and accelerates drying thanks to optimal air circulation.



Maximum stability and ruggedness thanks to the use of steel and high-quality processing.



Integrated security compartment for the secure storage of valuable items like wallets and smartphones.



# The C + P professional team

## Easy to combine.



Maxi



Flexo



Flexo White



Kombi

All fire service lockers are available:



Floor-standing (optionally, wall-mounted)



With feet, 100 mm



With base, 100 mm

Advantages	Model	Maxi	Flexo	Flexo White	Kombi	Praktus	Expert	Youngster	Aperto
Space for work clothing	1x complete	●	●	-	●	●	●	●	●
	2x complete	●	●	-	○	○	○	-	○
Helmet area	In the locker	●	●	-	●	-	●	●	-
	On the locker	●	●	-	●	●	●	●	●
Security compartment/ Combination compartment	Separate small security compartment	●	●	-	-	-	-	-	-
	Separate large security compartment	-	-	-	●	●	-	-	-
	Separate combination compartment (for helmet or personal use)	-	-	-	-	-	●	●	-
Clean area/ Personal compartment	Individual locker compartment for street clothing and personal items	●	-	●	-	-	-	-	-
	Especially large compartment for street clothing and personal items	-	-	-	●	-	-	-	●

● Ideally suitable/Features present      ○ Suitable to some extent      - Not suitable/Features not present



Praktus



Expert



Youngster



Aperto

Classic red? Sure, but it doesn't have to be. With fire service lockers from C+P, you not only choose the model and equipment, but the color, too. This way, your fire station not only benefits from order and functionality, but visual variety as well.

### Body color



Light gray RAL 7035    Anthracite gray RAL 7016    Fire red RAL 3000

### Front colors



Light gray RAL 7035    Anthracite gray RAL 7016    Fire red RAL 3000    White aluminum RAL 9006    Light blue RAL 5012    Clown green RDS 1108060    Pure orange RAL 2004

### Don't see the right configuration for your needs here?

Can't find the color you want? We'd be happy to make it all a reality for you. The C+P team is looking forward to your message:

[objektvertrieb@cp.de](mailto:objektvertrieb@cp.de)

# Laundry collecting and dispensing lockers



+ **Laundry bags** made of 100% polyester, with 4 hanging loops, packaging unit: 5 pc.



Order no. 48060-205





Order no. 48170-210

Version	White
& order no.	+ 48270-7015
& addtl. charge	

## Dimensions and design



With feet	Width	420	420	810	810	420
Locker height: 1,850	Doors	5	10	10	20	1
Locker depth: 500	Clear opening dimensions, HxWxD	Per door 269 x 251 x 475	Per door 126 x 251 x 475	Per door 269 x 295 x 475	Per door 126 x 295 x 475	Per swing flap 282 x 270 x 475
Foot height: 150	Description	<b>Laundry dispensing lockers</b> Featuring central door with which all vertically arranged compartments can be opened at the same time (e.g. for loading). Boxes and central doors with cylinder lock and 2 keys				<b>Laundry collection lockers</b> One swing flap at the top in the hinged door, hinged door with cylinder lock and 2 keys. Laundry-bag holder inside
	Order no.	48060-105	48060-110	48060-205	48060-210	48070-210
	Price					

With base	Width	420	420	810	810	420
Locker height: 1,800	Doors	5	10	10	20	1
Locker depth: 500	Clear opening dimensions, HxWxD	Per door 269 x 251 x 475	Per door 126 x 251 x 475	Per door 269 x 295 x 475	Per door 126 x 295 x 475	Per swing flap 282 x 270 x 475
Base height: 100	Description	See above				See above
	Order no.	48160-105	48160-110	48160-205	48160-210	48170-210
	Price					

→ **Body and door color**

Color concept → p. 48

# Laptop lockers

## Features of the laptop lockers:

- + The solution for secure and space-saving storage of 10 or 20 laptops, notebooks or tablets
- + Optionally available with power connection in each box (sockets always installed on left, locker connection cable included)
- + Sturdy steel construction with high-quality enamel coating
- + Either with feet or base as sub-frame
- + Doors hinged on the right, with sturdy swivel rod hinge
- + One cylinder lock with 2 keys for each door
- + Convenient doorstop silencer for pleasant closing



Optional electrification in each box for additional charge



Order no. 48010-1210 & 4800-1210 (electrification)

## Dimensions and design

Clear opening dimensions per door:  
148 x 330 x 478 mm (H x W x D)



### With feet

Locker height: 1,850	Width	420	810
Locker depth: 500	Compartments	1 x 400	2 x 400
Foot height: 150	Boxes	10	20
	Order no.	48010-1210	48010-2210
	Price		



Clear opening dimensions per door:  
148 x 330 x 478 mm (H x W x D)



### With base

Locker height: 1,800	Width	420	810
Locker depth: 500	Compartments	1 x 400	2 x 400
Base height: 100	Boxes	10	20
	Order no.	48020-1210	48020-2210
	Price		



- + **Electrification of all boxes**  
Per box: 1 grounded 2-pin 230 V plug  
(for sockets used outside Germany, please specify country code (e.g. FR for France) and inquire about prices)

& order no.	+ 4800-1210	+ 4800-2210
& addtl. charge		

## → Body and door color

Color concept → p. 48



# Loading assembled box lockers



Order no. 48020-1204EB



Order no. 48020-220404EB  
& 8x4800-7871 (PIN code locks)

## Dimensions and design

With cylinder lock (2 keys)  
Clear opening dimensions per door:  
375 x 330 x 465 (HxWxD)



### With base

Locker height: 1,800  
Locker depth: 500

Compartments	1x400	2x400
Locker width	420	810
Order no.	48020-1204EB	48020-220404EB
Price		

### + PIN code lock WF 1904, black



Number of key numbers	999.999
Color	schwarz
Order no.	4800-7871
Price	
Master key	
Order no.	08500-789
Price	

### → Body and door color

Color concept → p. 48



Company

Color concept

Changing room & wardrobe



**STORAGE SPACE**

The individual boxes provide enough space for any user. The steel used is smooth and easy to clean.



**ELECTRIFICATION**

Each box has two 230 V outlets which can be used to charge any devices with a conventional power connection.



**THEFT PROTECTION**

Each box is equipped with a cylinder lock and two keys as standard. Many other locking systems are available, e.g. PIN code lock, mechanical combination lock, safety turning bolt latch for padlock and lots more.

Workshop & factory

Office & archive

# Small-compartment and safe deposit box lockers



## Dimensions and design

Each box has cylinder lock and 2 keys, base in body color



### With base

Height: 1,950  
Width: 460  
Depth: 200

Boxes	30	20
Clear opening dimensions, H x W x D	98 x 190 x 180	158 x 190 x 180
Order no.	80700-201	80700-203
Price		



Each box has cylinder lock and 2 keys



### Wall-mounted

Height: 770  
Width: 460  
Depth: 200

Boxes	12	8
Clear opening dimensions, H x W x D	98 x 190 x 180	158 x 190 x 180
Order no.	80700-231	80700-233
Price		



Each box has cylinder lock and 2 keys



### Wall-mounted

Height: 1,130  
Width: 460  
Depth: 200

Boxes	18	12
Clear opening dimensions, H x W x D	98 x 190 x 180	158 x 190 x 180
Order no.	80700-221	80700-223
Price		



Order no. 80700-203



Number plates also available as option → p. 157

All small-compartment lockers (including the base version) are intended for wall mounting due to their depth. Suitable accessories for mounting for the respective wall to be provided by customer.

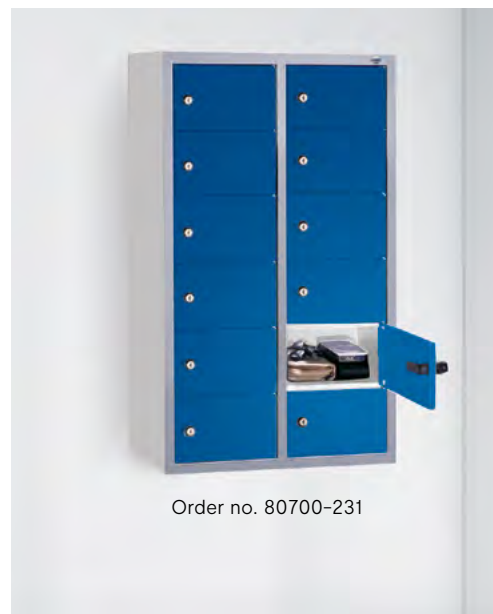

Order no. 80700-231

→ Body and door color

Color concept → p. 48



Order no. 8170-311



Order no. 8170-111

All safe deposit box lockers with louvers in the rear panel and 10 mm wall spacers (absolute body depth: approx. 480 mm)

## Dimensions and design

**Safe deposit box lockers** With 1, 2 or 3 x 11 compartments, doors reduced in size (e.g. for letter drop) with plastic label holder and cylinder lock with 2 keys, locker on black gray base



Height: 1,950  
Depth: 490



	Width	320	620	920
Boxes		11	22	33
Clear opening dimensions, H x W x D		Closed door: 23 x 250 x 460, Open door: 150 x 230 x 460		
Order no.		8170-111	8170-211	8170-311
Price				



# Classic PLUS compartment width: 250

## The space-savers.

### Single-tier lockers:

Inside each compartment:  
 1 non-adjustable storage shelf with  
 sturdy changing room rail below with  
 3 anti-rotation double sliding hooks

### Double-tier lockers:

Inside each box:  
 1 sturdy changing room rail with  
 3 anti-rotation double sliding hooks



Order no. 080000-19



Order no. 080000-29

## Dimensions and design

### Single-tier,

With safety turning bolt  
 Clear opening dimensions per door:  
 1,749 x 190 x 477 (H x W x D)



Floor-standing	Compartments	1x250	2x250	3x250	4x250
	Locker width	250	500	750	1000
Locker height: 1,850 Locker depth: 500	Order no.	080000-19	080000-29	080000-39	080000-49
	Price				

With feet	Compartments	1x250	2x250	3x250	4x250
	Locker width	250	500	750	1000
Locker height: 1,950 Locker depth: 500 Foot height: 100	Order no.	080010-19	080010-29	080010-39	080010-49
	Price				

With base	Compartments	1x250	2x250	3x250	4x250
	Locker width	250	500	750	1000
Locker height: 1,950 Locker depth: 500 Base height: 100	Order no.	080020-19	080020-29	080020-39	080020-49
	Price				

### → Body and door color

Color concept → p. 48



Order no. 080310-29



Order no. 080310-39



Order no. 080320-39

**Double-tier,**

With safety turning bolt  
Clear opening dimensions per door: 854x190x477 (HxWxD)



**Floor-standing**

Locker height: 1,850  
Locker depth: 500

	1x250	2x250	3x250	4x250
	250	500	750	1000
	080300-19	080300-29	080300-39	080300-49

**With feet**

Locker height: 1,950  
Locker depth: 500  
Foot height: 100

	1x250	2x250	3x250	4x250
	250	500	750	1000
	080310-19	080310-29	080310-39	080310-49

**With base**

Locker height: 1,950  
Locker depth: 500  
Foot height: 100

	1x250	2x250	3x250	4x250
	250	500	750	1000
	080320-19	080320-29	080320-39	080320-49

**+ Accessories (optional)**

Locks → p. 159









To the products →

# Workshop & factory

Order, safety and the support of functional work processes are important principles for the development of warehouse and workshop furniture.

At C + P, you'll find a product range that offers any solution you can imagine, from storage to workplace configuration.

Practical details, such as the patented Ergo-Lock grip lock in hinged-door cabinets, make your work easier and bring real benefit to your everyday workshop and warehouse routines.



# Cabinets, workbenches and shelving



# 262

Hinged-door cabinets



# 312

Sliding-door cabinets



To the products →



# 326

**Workbenches, drawer cabinets  
and mobile computer, measurement  
and testing stations**



# 340

**Shelf systems**

# Hinged-door cabinets

## Sturdy and practical.



### For tools and equipment

#### The cost-effective universal cabinets for warehouse and workshop

- + Sturdy steel construction with high-quality enamel coating
- + Zinc-plated shelves, drawers in light gray
- + **Ergo-Lock** grip lock (3-bolt) with 2 keys and optional exchangeable cylinder
- + Doors on bolt hinges, approx. 110° opening angle, models with drawer block have doors on external hinges, approx. 180° opening angle
- + Complete product line (different heights, dimension variants and shelf/drawer configurations for any requirement)

### With viewing windows

#### Tool cabinets with a view

- + Sturdy steel construction with high-quality enamel coating
- + Zinc-plated shelves
- + **Ergo-Lock** grip lock (3-bolt) with 2 keys and optional exchangeable cylinder
- + Doors on external hinges, approx. 180° opening angle
- + **Steel doors with viewing window made of acrylic glass for direct viewing**
- + Complete product line (different heights, dimension variants and shelf/drawer configurations for any requirement)



Loads of up to **700 kg**

## For heavy loads

### The strong cabinets for heavy loads

- + Sturdy steel construction with high-quality enamel coating
- + Zinc-plated shelves, reinforced
- + **Ergo-Lock** grip lock (3-bolt) with 2 keys and optional exchangeable cylinder
- + Doors on external hinges, approx. 180° opening angle
- + **Load capacity per shelf: 110 kg, cabinet load: 700 kg**
- + Complete product line (different heights, dimension variants and shelf/drawer configurations for any requirement)



Loads of up to **700 kg**

## For heavy loads with a viewing window

### Hard workers with a view

- + Sturdy steel construction with high-quality enamel coating
- + Zinc-plated shelves
- + **Ergo-Lock** grip lock (3-bolt) with 2 keys and optional exchangeable cylinder
- + Doors on external hinges, approx. 180° opening angle
- + **Load capacity per shelf: 110 kg, cabinet load: 700 kg**
- + **Steel doors with viewing window made of acrylic glass for direct viewing**
- + Complete product line (different heights, dimension variants and shelf/drawer configurations for any requirement)



# The patented Ergo-Lock from C+P



Outstanding operating safety, wear resistance and an attractive appearance characterize the patented “Ergo-Lock” grip lock from C+P. The **“simply push shut to close”** feature in particular already makes the work of hundreds of thousands of users easier—and soon yours, too!

## Features of the Ergo-Lock:

- + **High-quality appearance – current and contemporary**  
Fits in with any room and gives your cabinet a distinctive look.
- + **Patented “simply push shut to close” mechanism**  
Neatly close a cabinet, even if your hands are full—only from C+P.
- + **Exchangeable cylinder, subsequent replacement, simultaneous locking—it’s all possible!**  
Remain open to future change and safeguard the security of your investment.
- + **Suitable locking systems with PIN code or transponder with the same appearance.**  
Use a PIN code or transponder instead of a key with the same design if required for security purposes. As a complete, electronic offline lock, the Ergo-Lock offers full state-of-the-art features.



Whether you use it as a key lock or with PIN codes or transponders, the Ergo-Lock product range offers the right system to suit every requirement.



To Ergo-Lock →

Opt for security and access control to suit your particular needs:



### Mechanical locking system

- + 2 keys per lock
- + Standard design for all tool hinged-door cabinets (unless specified otherwise)
- + Also easy and convenient to operate with gloves



### PIN code lock

- + Motorized locking bolt
- + 4 digits
- + 4- to 8-digit codes possible
- + Optical function feedback (green/red)
- + Master key code
- + Usage range: +5 to +40°C
- + Operated with 2 standard AA batteries (alkaline)
- + Batteries last for approx. 30,000 openings or approx. 3 years

Order no.	8900-750
-----------	----------

Price	
-------	--



### RFID transponder lock

- + Motorized locking bolt
- + Transponder type: MIFARE® DESFire®
- + Can be integrated into existing access control systems
- + USB programming interface
- + Optical function feedback (green/red)
- + Easy operation with programmable user and master cards, as well as a service card
- + Management software also available as an option
- + Usage range: +5 to +40°C
- + Operated with 2 standard AA batteries (alkaline)
- + Batteries last for approx. 30,000 openings or approx. 3 years

Order no.	8900-740
-----------	----------

Price	
-------	--

	On request
--	------------

# Hinged-door cabinets for tools and equipment

## Features of the tool and equipment cabinets:

- + Sturdy steel construction with high-quality enamel coating
- + Wide range of different dimensions for any application
- + Improved operating safety, wear resistance and an attractive ergonomic appearance thanks to the **Ergo-Lock** grip lock (3-bolt latch) in black with 2 keys
- + Doors on bolt hinges, door opening angle of approx. 110°
- + Door reinforcement for high stability
- + Highly flexible interior fittings thanks to adjustability in 15 mm steps
- + High load capacity of 70 kg per zinc-plated shelf (reinforced shelf can bear loads up to 110 kg), for reinforcement, see p. 279



Order no. 08920-00

## Dimensions and version

With triple-bolt Ergo-Lock grip lock

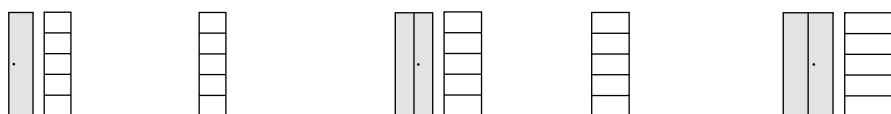

Height: 1,950	Width	500	500	700	700	930
	Depth:	400	500	400	500	400
	Interior dimensions, H x W x D	1840 x 498 x 353	1840 x 498 x 453	1840 x 698 x 353	1840 x 698 x 453	1840 x 928 x 353
	Shelves	4	4	4	4	4
	Order no.	8900-00	8901-00	8910-00	8911-00	8920-00
	Price					

### + Additional shelves

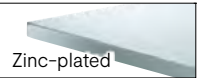
	Width x depth	495 x 352	495 x 452	695 x 352	695 x 452	925 x 352
	& order no.	+ 8900-80	+ 8901-80	+ 8910-80	+ 8911-80	+ 8920-80
	& unit price					

### + Underframes made of square tube, 150 mm high, adjustable level Black gray RAL 7021, other colors on request

	Width x depth	-	-	-	-	930 x 400
	& order no.	-	-	-	-	+ 9964-00
	& unit price	-	-	-	-	



XXL



**Ergo-Lock grip lock**

Improved operation safety, wear resistance and appearance—to close the door, all you need to do is push the grip lock closed



**XXL depth!**  
Order no. 08934-00

		XXL depth!				XXL depth!
930	930	930	1200	1200	1200	1200
500	600	800	400	500	600	800
1840x928x453	1840x928x553	1840x928x753	1840x1198x353	1840x1198x453	1840x1198x553	1840x1198x753
4	4	4	4	4	4	4
8921-00	8922-00	8924-00	8930-00	8931-00	8932-00	8934-00
<hr/>						
925x452	925x552	925x752	1195x352	1195x452	1195x552	1195x752
+ 8921-80	+ 8922-80	+ 8924-80	+ 8930-80	+ 8931-80	+ 8932-80	+ 8934-80
<hr/>						
930x500	930x600	930x800	1200x400	1200x500	1200x600	1200x800
+ 9984-00	+ 9994-00	+ 2032-00	+ 2027-00	+ 2028-00	+ 2033-00	+ 2034-00

**+ Accessories (optional)**

Locks → p. 283



# Workshop shelving units



Order no. 8911-02



Order no. 8920-02

## Dimensions and version

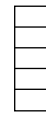
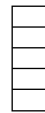
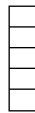
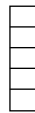

### Without doors

Height: 1,950

Width	500	500	700	700	930
Depth	400	500	400	500	400
Interior dimensions, H x W x D	1840 x 498 x 353	1840 x 498 x 453	1840 x 698 x 353	1840 x 698 x 453	1840 x 928 x 353
Shelves	4	4	4	4	4
Order no.	8900-02	8901-02	8910-02	8911-02	8920-02
Price					

### + Additional shelves

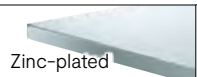
 <p>Zinc-plated</p>	Width x depth	495 x 352	495 x 452	695 x 352	695 x 452	925 x 352
	& order no.	+ 8900-80	+ 8901-80	+ 8910-80	+ 8911-80	+ 8920-80
	& unit price					



Company

Color concept

Changing room & wardrobe

Workshop & factory

Office & archive

		XXL depth!				XXL depth!
930	930	930	1200	1200	1200	1200
500	600	800	400	500	600	800
1840 x 928 x 453	1840 x 928 x 553	1840 x 928 x 753	1840 x 1198 x 353	1840 x 1198 x 453	1840 x 1198 x 553	1840 x 1198 x 753
4	4	4	4	4	4	4
8921-02	8922-02	8924-02	8930-02	8931-02	8932-02	8934-02
925 x 452	925 x 552	925 x 752	1195 x 352	1195 x 452	1195 x 552	1195 x 752
+ 8921-80	+ 8922-80	+ 8924-80	+ 8930-80	+ 8931-80	+ 8932-80	+ 8934-80

# Hinged-door cabinets

## for tools and equipment

### Dimensions and version

With drawers and shelves,  
incl. triple-bolt **Ergo-Lock** grip lock  
Drawers on sturdy guide slide bearing,  
load capacity: 25 kg each

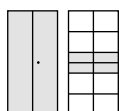

Height: 1,950	Width	930	1200	930
Depth: 500	Interior dimensions, HxWxD	1840x928x453	1840x1198x453	1840x928x453
	Shelves	6	6	6
	Description	Left and right 2 large drawers each	Left and right 2 large drawers each	4 small drawers on left, 2 large drawers on right
	Clear drawer interior dimensions, HxWxD*	125x367x438	125x502x438	70/125x367x438
	Order no.	8921-3042	8931-3042	8921-3041
	Price			

### + Additional shelves

 Zinc-plated	For cabinet width	930	1200
	Width x depth	459 x 449	594 x 449
	& order no.	+ 8921-3707	+ 8931-3707
	& unit price		

### + Drawer block



Generally in light gray RAL 7035	With 2 large drawers (from model 8921/31-3042)		With 4 small drawers (from model 8921/31-3041)	
For cabinet width	930	1200	930	1200
Drawer panel height	Approx. 170	Approx. 170	Approx. 82	Approx. 82
& order no.	+ 8921-3723	+ 8931-3723	+ 8921-3722	+ 8931-3722
& price				

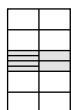

1200	930	1200
1840 x 1198 x 453	1840 x 928 x 453	1840 x 1198 x 453
6	6	6
4 small drawers on left, 2 large drawers on right	4 small drawers and 4 large drawers on left	4 small drawers and 4 large drawers on left
70/125 x 502 x 438	70/125 x 367 x 438	70/125 x 502 x 438
8931-3041	8921-305	8931-305



Order no. 8921-3041

\*Panel height: 82 or 170 mm

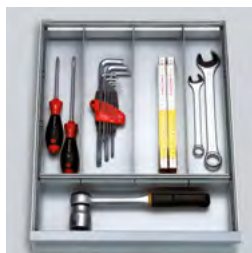

Order no. 8921-3716

**+** Drawer tidies



	Plastic boxes for small parts, approx. 54 mm high		Zinc-plated separators, approx. 68 mm high	
For cabinet width	930	1200	930	1200
& order no.	+ 8921-3713	+ 8931-3713	+ 8921-3716	+ 8931-3716
& price				



Order no. 8921-700

**+** Foam rubber mat to be inserted into the drawer

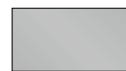
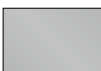

For cabinet width	930	1200
Depth	500	500
& order no.	+ 8921-700	+ 8931-700
& unit price		

**+** Accessories (optional)

Locks → p. 283



# Hinged-door cabinets

## for tools and equipment

### Dimensions and version

With security compartments, drawers and shelves, incl. triple-bolt **Ergo-Lock** grip lock  
 Drawers on sturdy guide slide bearing,  
 load capacity: 25 kg each

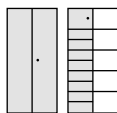

#### With hinged doors

Height: 1,950  
 Depth: 500

	930	1200	930
Width	930	1200	930
Interior dimensions, HxWxD	1840 x 928 x 453	1840 x 1198 x 453	1840 x 928 x 453
Shelves	4	4	4
Description	1 security compartment with cylinder lock, 8 large drawers on left	1 security compartment with cylinder lock, 8 large drawers on left	1 security compartment with cylinder lock, 16 small drawers on left
Security compartment dimensions, HxWxD	400 x 376 x 460	400 x 511 x 460	400 x 376 x 460
Clear drawer interior dimensions, HxWxD*	125 x 367 x 438	125 x 502 x 438	70 x 367 x 438
Order no.	8921-306	8931-306	8921-301
Price			

\*Panel height: 82 or 170 mm

#### + Additional shelves

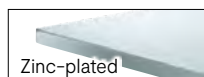

	930	1200
For cabinet width	930	1200
Width x depth & order no.	459 x 449 + 8921-3707	594 x 449 + 8931-3707
& unit price		

#### + Drawer block



	With 2 large drawers (from model 8921/31-3042)		With 4 small drawers (from model 8921/31-3041)	
Generally in light gray RAL 7035				
For cabinet width	930	1200	930	1200
Drawer panel height & order no.	Approx. 170 + 8921-3723	Approx. 170 + 8931-3723	Approx. 82 + 8921-3722	Approx. 82 + 8931-3722
& price				

#### + Drawer tidies



	Plastic boxes for small parts, approx. 54 mm high		Zinc-plated separators, approx. 68 mm high	
For cabinet width & order no.	930 + 8921-3713	1200 + 8931-3713	930 + 8921-3716	1200 + 8931-3716
& price				



Order no. 8921-3713



1200	930	1200	930	1200
1840 x 1198 x 453	1840 x 928 x 453	1840 x 1198 x 453	1840 x 928 x 453	1840 x 1198 x 453
4	-	-	-	-
1 security compartment with cylinder lock, 16 small drawers on left	1 security compartment on left and right, with cylinder lock, 16 small drawers on the left, 8 large drawers on the right	1 security compartment on left and right, with cylinder lock, 16 small drawers on the left, 8 large drawers on the right	1 compartment at top on left and right, 16 small drawers on the left, 8 large drawer on the right	1 compartment at top on left and right, 16 small drawers on the left, 8 large drawers on the right
400 x 511 x 460	400 x 376 x 460	400 x 511 x 460	400 x 376 x 460	400 x 511 x 460
70 x 502 x 438	70/125 x 367 x 438	70/125 x 502 x 438	70/125 x 367 x 438	70/125 x 502 x 438
8931-301	8921-302	8931-302	8921-303	8931-303



+ **Foam rubber mat to be inserted into the drawer**



For cabinet width	930	1200
Depth	500	500
& order no.	+ 8921-700	+ 8931-700
& unit price		



Order no. 8921-3042

+ **Keys and locks for tool and equipment cabinets (for PIN and RFID locks, see p. 265)**



	Ergo-Lock	Ergo-Lock with master key system	Master key for this	Ergo-Lock with simultaneous locking	Ergo-Lock with lock no. upon request (longer delivery times)	Single/spare key	Single/spare key for master key system	Single/spare key for security compartment
Order no.	8900-721	8900-723	8900-7131	8900-7211	...-...99	0004-11	0005-10	0006-50
Price					On request			

# Top, hanging and occasional cabinets



## Dimensions and version

**Top cabinet** with triple-bolt **Ergo-Lock** grip lock, incl. accessories for mounting to underbench cabinet



Height: 500	Width	930	930	930	1200	1200	1200
	Depth	400	500	600	400	500	600
	Interior dimensions, H x W x D	440 x 928 x 353	440 x 928 x 453	440 x 928 x 553	440 x 1198 x 353	440 x 1198 x 453	440 x 1198 x 553
	Shelves	-	-	-	-	-	-
	Order no.	9264-000	9284-000	9294-000	9464-000	9484-000	9494-000
Price							

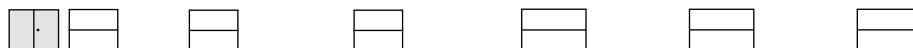

Height: 790	Width	930	930	930	1200	1200	1200
	Depth	400	500	600	400	500	600
	Interior dimensions, H x W x D	730 x 928 x 353	730 x 928 x 453	730 x 928 x 553	730 x 1198 x 353	730 x 1198 x 453	730 x 1198 x 553
	Shelves	1	1	1	1	1	1
	Order no.	9265-009	9285-009	9295-009	9465-009	9485-009	9495-009
Price							

### Wall mount

Customer must provide wall mount for top cabinets.

### Hanging cabinet/Hanging shelf

For example for hanging above the workbench, cabinet with doors on bolt hinges and triple-bolt **Ergo-Lock** grip lock, shelving without doors



Height: 830	<b>Version</b>	<b>Cabinet</b>	<b>Shelving</b>
Width: 700	Interior dimensions, H x W x D	770 x 695 x 250	770 x 695 x 250
Depth: 300	Shelves	3	3
	Order no.	134013-22	134013-02
	Price		



Order no. 134013-22



Order no. 8820-000



Order no. 8831-000

## Dimensions and version

**Occasional cabinets**  
With triple-bolt **Ergo-Lock** grip lock,  
with corrugated rubber mat

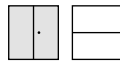

Height: 1,000	Width	930	930	1200	1200
	Depth	400	500	400	500
	Interior dimensions, HxWxD	855 x 928 x 353	855 x 928 x 453	855 x 1198 x 353	855 x 1198 x 453
	Shelves	1	1	1	1
	Order no.	8820-000	8821-000	8830-000	8831-000
	Price				



Height: 1,200	Width	930	930	1200	1200
	Depth	400	500	400	500
	Interior dimensions, HxWxD	1055 x 928 x 353	1055 x 928 x 453	1055 x 1198 x 353	1055 x 1198 x 453
	Shelves	2	2	2	2
	Order no.	8520-000	8521-000	8530-000	8531-000
	Price				

### + Occasional cabinets, simultaneous locking

& order no. + 8900-7211  
& addtl. charge

### + Top decor

Color overview → p. 52

### + Additional shelves

Selection → p. 272



# Occasional cabinets with hinged doors

## Features of the occasional cabinets:

These classics shouldn't be missing from any workshop. Outfit your cabinet with our accessories however you like: Storage space near the workstation or mobile helper—everything's possible!

- + Sturdy steel construction with high-quality enamel coating
- + Central door reinforcement for high stability of the doors
- + Hinged doors on bolt hinges with approx. 110° opening angle
- + Cylinder lock with 2 keys
- + Highly flexible interior thanks to adjustability in 30 mm steps
- + High load capacity of each zinc-plated shelf: 70 kg



Order no. 87210-00  
& 8721-71656



Order no. 87210-00  
& 8721-713  
& 8750-00  
& 8721-7010



Order no. 87210-00  
& 8721-713



Order no. 88210-00  
& 8721-7010

## Dimensions and version

1 drawer above, 2 adjustable, zinc-plated shelves below

Height: 1,000	Width	500	1000
Depth: 500	Shelves	2	2
	Order no.	87210-00	88210-00
	Price		

### + Additional shelves

	Width	500	1000
	Order no.	8721-80	88210-80
	Price		



Company

Color concept



**Corrugated rubber mat** for customer attachment to the housing or raised edge

Width	500	1000
Order no.	8750-00	88500-00
Price		



**Raised edge** for customer attachment

Width	500	1000
Depth	500	500
Height	20	20
Order no.	8721-713	8821-713
Price		



**Tabletop lectern, 500x500, for customer attachment, light gray in color**

Width	500
Depth	500
Order no.	8721-71656
Price	



Our tabletop lectern is also suitable for use for cabinet widths up to 1,000 mm!



**4 casters, 2 with lock, for installation by customer**

Order no.	8721-7010
Price	

Changing room & wardrobe

Workshop & factory

Office & archive

+ Occasional cabinet colors

Selection → p. 48

# Hinged-door cabinets for tools and equipment



Order no. 8920-314



Order no. 8921-311

## Dimensions and version

With triple-bolt Ergo-Lock grip lock

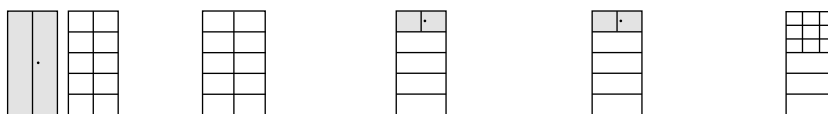

Various interior fittings	Width	930	1200	930	930	930
	Depth	500	500	400	500	400
Height: 1,950	Interior dimensions, H x W x D	1840 x 460 x 450	1840 x 595 x 450	1840 x 928 x 353	1840 x 928 x 453	1840 x 928 x 353
	Shelves	8	8	3	3	2
	Two-door security compartment, H x W x D	-	-	1 335 x 755 x 335	1 335 x 755 x 435	-
	Description	With center partition	With center partition	Security compartment with cylinder lock	Security compartment with cylinder lock	9 width-adjustable boxes above
	Order no.	8921-311	8931-311	8920-313	8921-313	8920-314
	Price					

## + Additional shelves

 Zinc-plated	Width x depth	459 x 449	594 x 449	925 x 352	925 x 452	925 x 352
	& order no.	+ 8921-3707	+ 8931-3707	+ 8920-80	+ 8921-80	+ 8920-80
	& unit price					



Order no. 8920-313

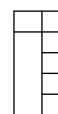
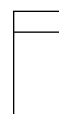
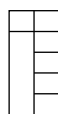
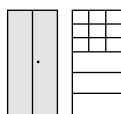

930	1200	1200	930	930	930
500	400	500	500	500	400
1840 x 928 x 453	1840 x 1198 x 353	1840 x 1198 x 453	1840 x 460 x 450	1840 x 928 x 453	1840 x 375 x 350
2	2	2	4 on the right	-	4 on the right
-	-	-	-	-	-
9 width-adjustable boxes above	9 width-adjustable boxes above	9 width-adjustable boxes above	With center partition, storage shelf with changing room rail (without coat hangers) on left	Interior storage shelf with changing room rail (without coat hangers)	With partition, storage shelf on left with fully extendable changing room rail (without coat hangers), filling section: approx. 380 mm wide, clothing section: approx. 550 mm wide
8921-314	8930-314	8931-314	8921-312	9280-088	8920-312

925 x 452	1195 x 352	1195 x 452	459 x 449	925 x 452	375 x 349
+ 8921-80	+ 8930-80	+ 8931-80	For right side + 8921-3707	+ 1050-80	For right side + 8920-3707

**+** Reinforced shelf



Load capacity per shelf	<b>Approx. 110 kg</b>
Order no.	+ ...-802
Price	Double the shelf price



# Tool cabinets with drawer block

## Features of the tool cabinets with drawer block:

- + Sturdy steel construction with high-quality enamel coating
- + Different dimension variants (2 widths, 2 heights, 3 depths)
- + Improved operating safety, wear resistance and appearance thanks to the **Ergo-Lock** grip lock (3-bolt latch) in black with 2 keys
- + 3 drawers with telescopic rail guide, fully extendable, 50 kg load capacity/drawer
- + Door mounting bracket with external hinges, approx. 180° opening angle
- + Highly flexible interior fittings thanks to adjustability in 15 mm steps
- + High load capacity of 70 kg per zinc-plated shelf (reinforced shelf can bear loads up to 110 kg), for reinforcements see below



Order no. 8931-503  
& 8931-5713 (drawer tidy/plastic boxes)

## Dimensions and version

With hinged doors on external hinges (door opening angle of 180°), 3 drawers with telescopic rail guide, fully extendable with approx. 50 kg load capacity/drawer, wall mounting necessary

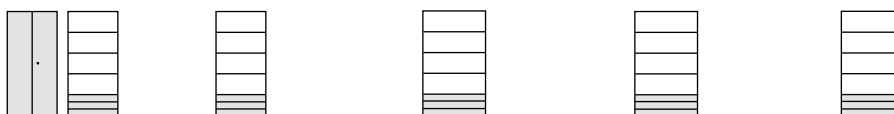

Drawers below Height: 1,950	Width	930	930	1200	1200	1200
	Depth	500	600	400	500	600
	Shelves	4	4	4	4	4
	Drawer interior dimensions, HxWxD	100x730x440	100x730x440	100x1000x330	100x1000x440	100x1000x440
	Drawers	3	3	3	3	3
	Order no.	8921-503	8922-503	8930-503	8931-503	8932-503
	Price					

### + Additional shelves

For cabinet width	930	930	1200	1200	1200
Depth	500	600	400	500	600
& order no.	+ 8921-80	+ 8922-80	+ 8930-80	+ 8931-80	+ 8932-80
& unit price					



#### Ergo-Lock grip lock

Improved operation safety, wear resistance and appearance— to close the door, all you need to do is push the grip lock closed





Order no. 8921-5030



Order no. 8931-5030  
& 8931-5713 (drawer tidy/plastic boxes)

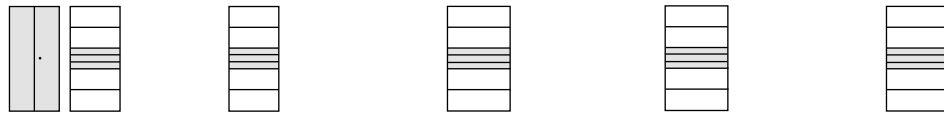

**Drawers in the center**

Height: 1,950

	930	930	1200	1200	1200
	500	600	400	500	600
	3	3	3	3	3
	100x730x440	100x730x440	100x1000x330	100x1000x440	100x1000x440
	3	3	3	3	3
	8921-5030	8922-5030	8930-5030	8931-5030	8932-5030

	930	930	1200	1200	1200
	500	600	400	500	600
	+ 8921-80	+ 8922-80	+ 8930-80	+ 8931-80	+ 8932-80

**+ Reinforced shelf**



Load capacity per shelf	<b>Approx. 110 kg</b>
Order no.	+ ...-802
Price	Double the shelf price

**+ Accessories (optional)**

Foam rubber mats etc. → p. 283

# Occasional cabinets with drawer block



Order no. 8831-5035  
& 8931-5713 (drawer tidy/plastic boxes)

## Dimensions and version

With hinged doors on external hinges (door opening angle of 180°), with corrugated rubber mat, wall mounting necessary



Height: 1,000	Width	930	1200	1200
	Depth	500	400	500
	Interior dimensions, HxWxD	450 x 928 x 453	450 x 1198 x 353	450 x 1198 x 453
	Shelves	2	2	2
	Drawer interior dimensions, HxWxD	100 x 730 x 440	100 x 1000 x 330	100 x 1000 x 440
	Drawers	3	3	3
	Order no.	8821-5035	8830-5035	8831-5035
	Price			

# Drawer tidies



## Drawer tidies

Plastic boxes for small parts, 63 mm high



For cabinet width	930	1200	1200
Depth	500/600	400	500/600
Boxes	4 x 162 x 108 8 x 108 x 108 16 x 54 x 54 16 x 108 x 54	6 x 162 x 108 6 x 108 x 108 12 x 54 x 54 18 x 108 x 54	8 x 162 x 108 8 x 108 x 108 16 x 54 x 54 24 x 108 x 54
& order no.	+ 8921-5713	+ 8930-5713	+ 8931-5713
& unit price			



## Drawer tidies

Zinc-plated separators, approx. 68 mm high

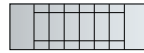

For cabinet width	930	1200	1200
Depth	500/600	400	500/600
Boxes (vertically adjustable)	2 x 134 x 420 12 x 95 x 110/199	2 x 161 x 315 18 x 95 x 57/199	2 x 161 x 420 18 x 95 x 110/199
& order no.	+ 8921-5718	+ 8930-5718	+ 8931-5718
& unit price			

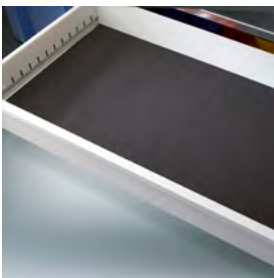

## Foam rubber mat

To be inserted into the drawer

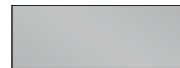

For cabinet width	930	1200	1200
Depth	500/600	400	500/600
& order no.	+ 8921-701	+ 8930-701	+ 8931-701
& unit price			

## Keys and locks for tool and equipment cabinets

(for PIN code and RFID locks, see p. 265)

	Ergo-Lock	Ergo-Lock with master key system	Master key for this	Ergo-Lock with simultaneous locking	Single/spare key	Additional charge for lock with lock no. upon request (longer delivery times)	Single/spare key for master key system
Order no.	8900-721	8900-723	8900-7131	8900-7211	0004-11	...-...99	0005-10
Price						On request	



# Tool and equipment cabinets

## With viewing windows

### Features of the tool cabinets with viewing windows:

- + Sturdy steel construction with high-quality enamel coating
- + Different dimension variants (2 widths, 3 heights)
- + Door mounting bracket with external hinges, approx. 180° opening angle
- + Steel doors with viewing window made of acrylic glass (3 mm thick) for a direct view
- + Acrylic glass panes can be replaced using simple screw connection
- + Highly flexible interior thanks to adjustability in 15 mm steps
- + High load capacity of 70 kg per zinc-plated shelf (reinforced shelf can bear loads up to 110 kg), for reinforcement, see Seite 281

#### Ergo-Lock grip lock

Improved operation safety, wear resistance and appearance—to close the door, all you need to do is push the grip lock closed



### Dimensions and version

With hinged doors on external hinges (door opening angle of 180°), incl. Ergo-Lock triple-bolt grip lock

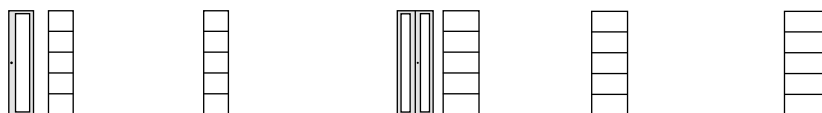

Height: 1,950	Width	500	500	700	700	930
	Depth	400	500	400	500	400
	Interior dimensions, HxWxD	1840x498x353	1840x498x453	1840x698x353	1840x698x453	1840x928x353
	Shelves	4	4	4	4	4
	Order no.	8900-055	8901-055	8910-055	8911-055	8920-055
	Price					

#### + Additional shelves

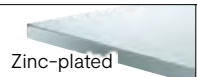
 <p>Zinc-plated</p>	Width x depth	495 x 352	495 x 452	695 x 352	695 x 452	925 x 352
	& order no.	+ 8900-80	+ 8901-80	+ 8910-80	+ 8911-80	+ 8920-80
	& unit price					



Order no. 8521-055

#### → Body and door color

Color concept → p. 48



### Cabinets that earn money

#### Finding instead of searching saves time and money!

- + Simply brilliant: Thanks to the direct view of the cabinet contents, you eliminate tedious searching and cumbersome labeling systems. Better order is automatically kept in viewing window cabinets as well.
- + Die C + P cabinets with viewing windows pay for themselves after just a short period of time—and then they even make you money by saving time and costs!
- + They're also perfectly suited for the implementation of modern simplification and improvement concepts such as KAIZEN or CPI.

			XXL depth!		XXL depth!	
930	930	930	1200	1200	1200	1200
500	600	800	400	500	600	800
1840 x 928 x 453	1840 x 928 x 553	1840 x 928 x 753	1840 x 1198 x 353	1840 x 1198 x 453	1840 x 1198 x 553	1840 x 1198 x 753
4	4	4	4	4	4	4
8921-055	8922-055	8924-055	8930-055	8931-055	8932-055	8934-055
925 x 452	925 x 552	925 x 752	1195 x 352	1195 x 452	1195 x 552	1195 x 752
+ 8921-80	+ 8922-80	+ 8924-80	+ 8930-80	+ 8931-80	+ 8932-80	+ 8934-80

## Dimensions and version

### Occasional cabinets with viewing windows

With hinged doors on external hinges (door opening angle of 180°), incl. Ergo-Lock triple-bolt grip lock with corrugated rubber mat



Depth: 500	Height	1000	1000	1200	1200
	Width	930	1200	930	1200
	Interior dimensions, H x W x D	855 x 928 x 453	855 x 1198 x 453	1055 x 928 x 453	1055 x 1198 x 453
	Shelves	1	1	2	2
	Order no.	8821-055	8831-055	8521-055	8531-055
	Price				

# Tool cabinets with viewing windows and drawer block



Order no. 8931-553

## Dimensions and version

**With hinged doors** on external door hinges (door opening angle of 180°), 3 drawers with telescopic rail guide, fully extendable with approx. 50 kg load capacity/drawer, wall mounting necessary



Drawer below	Width	930	930	1200	1200
Height: 1,950	Depth	500	600	500	600
	Interior dimensions, HxWxD	1840x928x453	1840x928x553	1840x1198x453	1840x1198x553
	Shelves	4	4	4	4
	Drawer interior dimensions, HxWxD	100x730x440	100x730x440	100x1000x440	100x1000x440
	Drawers	3	3	3	3
	Order no.	8921-553	8922-553	8931-553	8932-553
	Price				

→ **Body and door color**

Color concept → p. 48



Order no. 8931-5530



**Drawers in the center**  
Height: 1,950

Width	930	930	1200	1200
Depth	500	600	500	600
Interior dimensions, HxWxD	1840 x 928 x 453	1840 x 928 x 553	1840 x 1198 x 453	1840 x 1198 x 553
Shelves	3	3	3	3
Drawer interior dimensions, HxWxD	100 x 730 x 440	100 x 730 x 440	100 x 1000 x 440	100 x 1000 x 440
Drawers	3	3	3	3
Order no.	8921-5530	8922-5530	8931-5530	8932-5530
Price				

**+ Additional shelves**

 Zinc-plated	Width x depth	925 x 452	925 x 552	1195 x 452	1195 x 552
	& order no.	+ 8921-80	+ 8922-80	+ 8931-80	+ 8932-80
	& unit price				

**+ Accessories**

Drawer ties, foam rubber mats and locks → p. 295



# Tool and equipment cabinets

## For heavy loads



### Features of the cabinets for heavy loads:

- + Sturdy steel construction with high-quality enamel coating
- + Different dimension variants (3 widths, 3 heights)
- + Door mounting bracket with external hinges, approx. 180° opening angle
- + Door reinforcement for high stability and concealed locking rod
- + Highly flexible interior fittings thanks to adjustability in 15 mm steps
- + High load capacity of each zinc-plated shelf: 110 kg
- + Cabinet load: 700 kg



Order no. 8921-052

Loads of up to **700 kg**

#### Ergo-Lock grip lock

Improved operation safety, wear resistance and appearance—to close the door, all you need to do is push the grip lock closed



### Dimensions and version

On external hinges (door opening angle of 180°), incl. Ergo-Lock triple-bolt grip lock

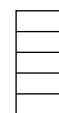
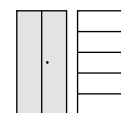
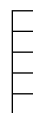

Height: 1,950	Width	500	500	930	930
	Depth	400	500	400	500
	Interior dimensions, H x W x D	1840 x 498 x 353	1840 x 498 x 453	1840 x 928 x 353	1840 x 928 x 453
	Shelves	4	4	4	4
	Order no.	8900-052	8901-052	8920-052	8921-052
	Price				

+ **Additional shelves**  
Load capacity: 110 kg

 Zinc-plated	Width x depth	495 x 352	495 x 452	925 x 352	925 x 452
	& order no.	+ 8900-802	+ 8901-802	+ 8920-802	+ 8921-802
	& unit price				

→ **Body and door color**

Color concept → p. 48



Order no. 8521-052

Loads of up to **700 kg**

**Occasional cabinets** with hinged doors on external hinges (door opening angle of 180°), incl. Ergo-Lock triple-bolt grip lock with corrugated rubber mat

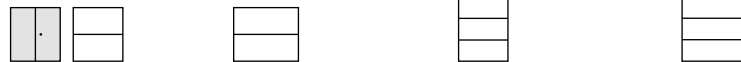

Depth: 500	Height	1000	1000	1200	1200
	Width	930	1200	930	1200
	Interior dimensions, HxWxD	855 x 928 x 453	855 x 1198 x 453	1055 x 928 x 453	1055 x 1198 x 453
	Shelves	1	1	2	2
	Order no.	8821-052	8831-052	8521-052	8531-052
	Price				

	<b>XXL depth!</b>				<b>XXL depth!</b>
930	930	1200	1200	1200	1200
600	800	400	500	600	800
1840 x 928 x 553	1840 x 928 x 753	1840 x 1198 x 353	1840 x 1198 x 453	1840 x 1198 x 553	1840 x 1198 x 753
4	4	4	4	4	4
8922-052	8924-052	8930-052	8931-052	8932-052	8934-052

925 x 552	925 x 752	1195 x 352	1195 x 452	1195 x 552	1195 x 752
+ 8922-802	+ 8924-802	+ 8930-802	+ 8931-802	+ 8932-802	+ 8934-802

**+ Accessories**

Locks → p. 295

# Tool cabinets for heavy loads

## with drawer block

### Dimensions and version

With hinged doors on external hinges (door opening angle of 180°), 3 drawers with telescopic rail guide, fully extendable with approx. 75 kg load capacity/drawer, wall mounting necessary



Drawers below Height: 1,950	Width	930	930	1200	1200
	Depth	500	600	500	600
	Interior dimensions, HxWxD	1435 x 928 x 453	1435 x 928 x 553	1435 x 1198 x 453	1435 x 1198 x 553
	Shelves	4	4	4	4
	Drawer interior dimensions, HxWxD	100 x 730 x 440	100 x 730 x 440	100 x 1000 x 440	100 x 1000 x 440
	Drawers	3	3	3	3
	Order no.	8921-523	8922-523	8931-523	8932-523
	Price				



Loads of up to **700 kg**

Order no. 8831-5235

+ **Foam rubber mat**  
To be inserted into the drawer

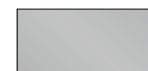
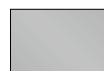

For cabinet width	930	1200
Depth	500/600	500/600
& order no.	+ 8921-701	+ 8931-701
& unit price		

**Occasional cabinets** with hinged doors on external hinges (door opening angle of 180°), 3 drawers with telescopic rail guide, fully extendable with approx. 75 kg load capacity/drawer, with corrugated rubber mat. Wall mounting necessary



Height: 1,000 Depth: 500	Width	930	1200
	Interior dimensions, HxWxD	450 x 925 x 453	450 x 1198 x 453
	Shelves	2	2
	Drawer interior dimensions, HxWxD	100 x 730 x 440	100 x 1000 x 440
	Drawers	3	3
	Order no.	8821-5235	8831-5235
	Price		

→ **Body and door color**

Color concept → p. 48



**Drawers in the center**

Height: 1,950

	930	930	1200	1200
	500	600	500	600
	1435 x 928 x 453	1435 x 928 x 553	1435 x 1198 x 453	1435 x 1198 x 553
	3	3	3	3
	100 x 730 x 440	100 x 730 x 440	100 x 1000 x 440	100 x 1000 x 440
	3	3	3	3
	8921-5230	8922-5230	8931-5230	8932-5230

**+ Additional shelves**  
Load capacity: 110 kg

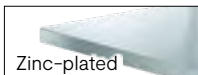
	For cabinet width	930	930	1200	1200
	Depth	500	600	500	600
	& order no.	+ 8921-802	+ 8922-802	+ 8931-802	+ 8932-802
	& unit price				

**+ Drawer tidies**  
Plastic boxes for small parts, 63 mm high



For cabinet width	930	1200
Depth	500/600	500/600
Boxes	4 x 162 x 108 8 x 108 x 108 16 x 54 x 54 16 x 108 x 54	8 x 162 x 108 8 x 108 x 108 16 x 54 x 54 24 x 108 x 54
& order no.	+ 8921-5713	+ 8931-5713
& unit price		

**+ Drawer tidies**  
Zinc-plated separators, approx. 68 mm high



For cabinet width	930	1200
Depth	500/600	500/600
Boxes (vertically adjustable)	2 x 134 x 420 12 x 95 x 110/199	2 x 161 x 420 18 x 95 x 110/199
& order no.	+ 8921-5718	+ 8931-5718
& unit price		



Order. 8931-5230 & 8931-5713

Loads of up to **700 kg**



# Heavy-duty cabinets with viewing window doors

- + Sturdy steel construction with high-quality enamel coating
- + Different dimension variants (3 widths, 3 heights)
- + Door mounting bracket with external hinges, approx. 180° opening angle
- + Steel doors with viewing window made of acrylic glass (3 mm thick) for a direct view
- + Acrylic glass panes can be replaced using simple screw connection
- + Door reinforcement for high stability and concealed locking rod
- + Highly flexible interior thanks to adjustability in 15 mm steps
- + High load capacity of each zinc-plated shelf: 110 kg
- + Cabinet load: 700 kg



Order no. 8924-0552

## Dimensions and version

With hinged doors on external door hinges (door opening angle of 180°), zinc-plated shelves, 110 kg load capacity/shelf

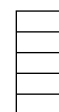
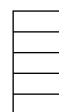
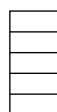
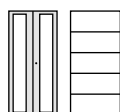

**XXL depth!**

### Without drawers

Height: 1,950

Width	930	930	930	930
Depth	400	500	600	800
Shelves	4	4	4	4
Order no.	8920-0552	8921-0552	8922-0552	8924-0552
Price				

## Dimensions and version

With hinged doors on external door hinges (door opening angle of 180°), 3 drawers with telescopic rail guide, fully extendable with approx. 75 kg load capacity/drawer, 110 kg load capacity/shelf, wall mounting necessary

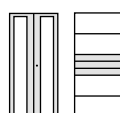

### Drawers in the center

Height: 1,950

Width	930	930	1200	1200
Depth	500	600	500	600
Shelves	3	3	3	3
Order no.	8921-55302	8922-55302	8931-55302	8932-55302
Price				



Order no. 8931-55302



Order no. 8931-5532

Loads of up to **700 kg**



1200

400

4

8930-0552



1200

500

4

8931-0552



1200

600

4

8932-0552



1200

800

4

8934-0552

**XXL depth!**

**Drawers below**

Height: 1,950

Width	930	930	1200	1200
Depth	500	600	500	600
Shelves	4	4	4	4
Order no.	8921-5532	8922-5532	8931-5532	8932-5532
Price				

→ **Body and door color**

Color concept → p. 48



**Ergo-Lock grip lock**  
(3-bolt latch)  
Easy to operate with gloves on



**Door opening angle**  
Approx. 180° thanks to external hinges



**Drawers with telescopic rail guide**, fully extendable, 75 kg load capacity per drawer



**Steel doors** with viewing windows made of permanently adhered 3 mm-thick acrylic glass and concealed locking rods

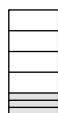
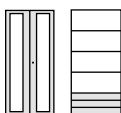

# Occasional cabinets



Order no. 8521-0552



Order no. 8821-0552

## Dimensions and version

With hinged doors on external door hinges (door opening angle of 180°), zinc-plated shelves, adjustable, 110 kg load capacity/shelf, corrugated rubber mat for top



Depth: 500	Height	1000	1000	1200	1200
	Width	930	1200	930	1200
	Shelves	1	1	2	2
	Order no.	8821-0552	8831-0552	8521-0552	8531-0552
	Price				

### + Accessories

Additional shelves → p. 288

# Drawer tidies



## Drawer tidies

Plastic boxes for small parts, 63 mm high

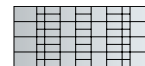

For cabinet width	930	1200	1200
Depth	500/600	400	500/600
Boxes	4 x 162 x 108 8 x 108 x 108 16 x 54 x 54 16 x 108 x 54	6 x 162 x 108 6 x 108 x 108 12 x 54 x 54 18 x 108 x 54	8 x 162 x 108 8 x 108 x 108 16 x 54 x 54 24 x 108 x 54
& order no.	+ 8921-5713	+ 8930-5713	+ 8931-5713
& unit price			



## Drawer tidies

Zinc-plated separators, approx. 68 mm high



For cabinet width	930	1200	1200
Depth	500/600	400	500/600
Boxes (vertically adjustable)	2 x 134 x 420 12 x 95 x 110/199	2 x 161 x 315 18 x 95 x 57/199	2 x 161 x 420 18 x 95 x 110/199
& order no.	+ 8921-5718	+ 8930-5718	+ 8931-5718
& unit price			

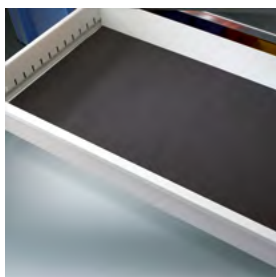

## Foam rubber mat

To be inserted into the drawer

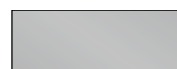
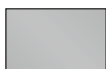

For cabinet width	930	1200	1200
Depth	500/600	400	500/600
& order no.	+ 8921-701	+ 8930-701	+ 8931-701
& unit price			

## Keys and locks for tool and equipment cabinets

(for PIN code and RFID locks, see p. 265)

	Ergo-Lock	Ergo-Lock with master key system	Master key for this	Ergo-Lock with simultaneous locking	Single/spare key	Additional charge for lock with lock no. upon request (longer delivery times)	Single/spare key for master key system
Order no.	8900-721	8900-723	8900-7131	8900-7211	0004-11	...-...99	0005-10
Price						On request	

→ Body and door color

Color concept → p. 48



# Hinged-door cabinets

Sturdy and practical.



## As battery charging cabinets

### The versatile electrical experts

- + Sturdy steel construction with high-quality enamel coating
- + Zinc-plated shelves
- + Special e-tray, permanently installed, with integrated socket strip
- + Ergo-Lock grip lock (3-bolt) with 2 keys and optional exchangeable cylinder
- + Doors on external hinges, approx. 180° opening angle
- + Rear panel perforated for optimal ventilation, Comfort version with fan
- + Available with solid-metal doors or with viewing windows made of acrylic glass for direct view
- + Basic or Comfort variant for any equipment and electrification needs

## As hazardous substance cabinets

### The secure cabinets for storing water-polluting substances

- + Protection against high consequential costs!
- + Sturdy steel construction with high-quality enamel coating
- + Trays made of zinc-plated steel or polyethylene
- + Ergo-Lock grip lock (3-bolt) with 2 keys and optional exchangeable cylinder
- + Various dimension variants and occasional cabinets



## With open-front containers

### The top-notchers for small parts

- + Sturdy steel construction with high-quality enamel coating
- + Zinc-plated shelves
- + Ergo-Lock grip lock (3-bolt) with 2 keys and optional exchangeable cylinder
- + Open-front containers in professional quality
- + Complete product line (different heights, dimension variants and box/drawer configurations for any requirement)



Tool sliding-door cabinets → p. 312

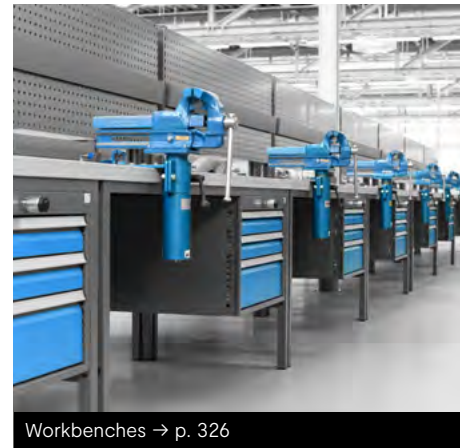

Workbenches → p. 326



Shelving → p. 340

# Battery charging cabinets

## Basic and Comfort versions.

### Features of the C + P battery charging cabinets:

- + Sturdy steel construction with high-quality enamel coating
- + Doors on external hinges, door opening angle of 180°
- + Available with solid-metal doors or viewing windows made of 3 mm-thick acrylic glass, easy replacement using simple screw connection
- + Ergo-Lock 3-bolt grip lock with 2 keys and patented mechanism: Simply push shut to close!
- + Highly flexible shelf configuration: Adjustability in 15 mm steps
- + Special e-tray, permanently installed, with integrated socket strip, for better order in the cabinet
- + Rear panel perforated for optimal ventilation, Comfort version with fan
- + Upgradable with C+P interior fittings, e.g. drawer block
- + Each cabinet incl. 3 m grounded supply line, 230 V
- + All cabinets comply with Low-Voltage Directive 2014/35/EU, EMC Directive 2014/30/EU & RoHS Directive 2011/65/EU



Basic version with solid-metal doors, order no. 8921-05E1

### Basic dimensions and version

With 3 zinc-plated shelves, one e-tray (electrical tray) and a 5x socket strip

Height: 1,950		With solid-metal doors	With viewing window doors
Width: 930	Shelves	3	3
Depth: 500	E-trays	1	1
	Order no.	8921-05E1	8921-055E1
	Price		



Patented mechanism: Simply push shut to close. Easy to operate with gloves on. Can also be used as PIN code and RFID transponder lock! (see Page 265)

### Comfort dimensions and version

With one zinc-plated shelf, 3 e-trays (electrical trays) and 5x socket strips, central master strip with fan connection FI circuit breaker and line circuit breaker

Height: 1,950		With solid-metal doors	With viewing window doors
Width: 930	Shelves	1	1
Depth: 500	E-trays	3	3
	Order no.	8921-05E3	8921-055E3
	Price		



Temperature-controlled fan and central master strip with COMFORT cabinet

### The innovative e-tray from C + P: Refined technology, easy to use

- + Concealed placement tray for power packs and supply cables of the charging units for better order
- + More space and better organization of the area
- + Holder and positioning of the socket strip (permanently connected to shelf)
- + Tray perforated to avoid overheating
- + Zinc-plated version
- + Other plug variants available on request



+ **Additional standard shelf**  
Zinc-plated

Order no.	8921-80
Price	



Basic version with viewing window doors  
Order no. 8921-055E1



Comfort version with solid-metal doors,  
order no. 8921-05E3



Comfort version with viewing window doors  
Order no. 8921-055E3

+ **Additional e-tray** only for BASIC cabinet, only one addtl. shelf with cabinet order possible (cannot be retrofitted), incl. supply line.

	Width	930
	Depth	500/600
	Order no.	+ 8921-80E1
	Price	

+ **Corrugated rubber mat** for placement on e-tray, For easy assembly, incl. tape strips

	Width	930
	Depth	500/600
	Order no.	+ 8921-703
	Price	

+ **Drawer tidy**, plastic boxes for small parts, approx. 63 mm high

	44 boxes: 4x 162x108 8x 108x108 16x 54x54 16x 108x54	
	Order no.	+ 8921-5713
	Price	

+ **Drawer tidy**, zinc-plated separators, approx. 68 mm high

	14 boxes: 2x 134x420 12x 95x110/199 (vertically adjustable)	
	Order no.	+ 8921-5718
	Price	

+ **Drawer block below** with 3 fully extendable drawers, 50 kg load capacity each, with telescopic rails

	Width	930
	Depth	500/600
	Order no.	+ 8921-5702
	Price	

+ **Foam rubber mat** to be inserted into the drawer for careful storage of sensitive stock items

	Width	930
	Depth	500/600
	Order no.	+ 8921-701
	Price	

→ **Body and door color**

Color concept → p. 48



# Hazardous substance cabinets



Order no. 8921-315

## Features of the hazardous substance cabinets:

- + Safe storage of small containers with water-polluting substances (no acids or alkalis)
- + Sturdy steel construction with high-quality enamel coating
- + Doors on bolt hinges, approx. 110° door opening angle, with easy to clean ventilation hole pattern above and below
- + Protection against consequential costs at a low price
- + Legally prescribed for many sectors (e.g. agricultural businesses)
- + Collection trays tested according to the German Water Resources Act (WHG)
- + Highly flexible interior fittings thanks to adjustability in 15 mm steps

## Dimensions and version

With hinged doors, with ventilation hole pattern, incl. Ergo-Lock triple-bolt grip lock

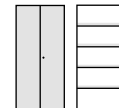
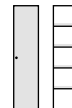
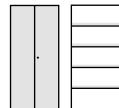
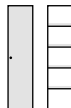

Height: 1.950	Width	500	930	500	930
Depth: 500	Interior dimensions, HxWxD	1840 x 498 x 453	1840 x 928 x 453	1840 x 498 x 453	1840 x 928 x 453
	Shelves	-	-	3	3
	Collection volume	10 L/tray	20 L/tray	10 L/tray	20 L/tray
	Zinc-plated trays	4	4	-	-
	Polyethylene trays	-	-	4	4
	Order no.	8901-315	8921-315	8901-316	8921-316
	Price				

+ Additional tray or polyethylene tray

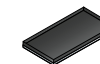
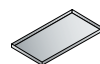

For cabinet width	500	930	500	930
Dimensions, WxD	490 x 450	920 x 450	490 x 450	920 x 450
Collection volume	10 L/tray	20 L/tray	10 L/tray	20 L/tray
& order no.	+ 8901-3725	+ 8921-3725	+ 8901-3726	+ 8921-3726
& addtl. charge				

→ Body and door color

Color concept → p. 48



Order no. 8821-315  
& 8851-00 (corrugated rubber mat for top)



Order no. 8721-315  
& 8751-00 (corrugated rubber mat for top)

## Dimensions and version

### Occasional safety cabinets

With hinged doors, with ventilation hole pattern, incl. Ergo-Lock triple-bolt grip lock

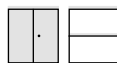

Height: 1,000 (incl. raised edge: 1,020)	Width	500	930	500	930
Depth: 500	Interior dimensions, HxWxD	855 x 498 x 453	855 x 928 x 453	855 x 498 x 453	855 x 928 x 453
	Shelves	-	-	1	1
	Collection volume	10 L/tray	20 L/tray	10 L/tray	20 L/tray
	Zinc-plated trays	2	2	-	-
	Polyethylene trays	-	-	2	2
	Order no.	8721-315	8821-315	8721-316	8821-316
	Price				

**+** Corrugated rubber mat for top



For cabinet width	500	930
& order no.	+ 8751-00	+ 8851-00
& addtl. charge		



**Zinc-plated tray:**  
Load capacity: 80 kg



**Polyethylene tray:**  
Load capacity: 70 kg

# Open-front container cabinets

## Features of the open-front container cabinets:

- + Sturdy steel construction with high-quality enamel coating
- + Wide range of different dimensions and container hardware for any application
- + Door mounting bracket with approx. 110° opening angle (except for models on page 310/311 (180°))
- + Central door reinforcement for high stability
- + Highly flexible interior fitting options thanks to adjustability in 10 mm steps (except models 8931-501 and -502 (15 mm steps))
- + Load capacity per zinc-plated shelf: 70 kg
- + Load capacity per shortened shelf: 50 kg
- + Cabinet load capacity: 450 kg
- + Wall mounting is necessary for sturdy and secure positioning. The fastening method depends on the wall material. Please use screws and dowels that are suitable for the respective type of wall (not included)
- + Cabinets with drawer block, 3 drawers each with telescopic rail guide, fully extendable, 50 kg load capacity/drawer



Order no. 130276-64



Extra-large cabinets with doors on external door hinges (door opening angle of 180°)

### Ergo-Lock grip lock

Improved operation safety, wear resistance and appearance—to close the door, all you need to do is push the grip lock closed



## Features of the open-front and shelf containers:

- + Smooth internal walls and recessed grip on the rear panel
- + Stacking lugs facilitate stacking without slippage
- + The slightly roughened bottom ensures anti-slip transport on conveyor belts
- + The open-front containers are made of polypropylene (food-safe and oil-resistant from -20 to +90°C). Available in 7 practical sizes and in the cadmium-free colors of red and blue
- + Can also be fitted with protective label covers, dust covers, front panels, and carrying bars as well as vertical dividers for more better organization



Shelf containers

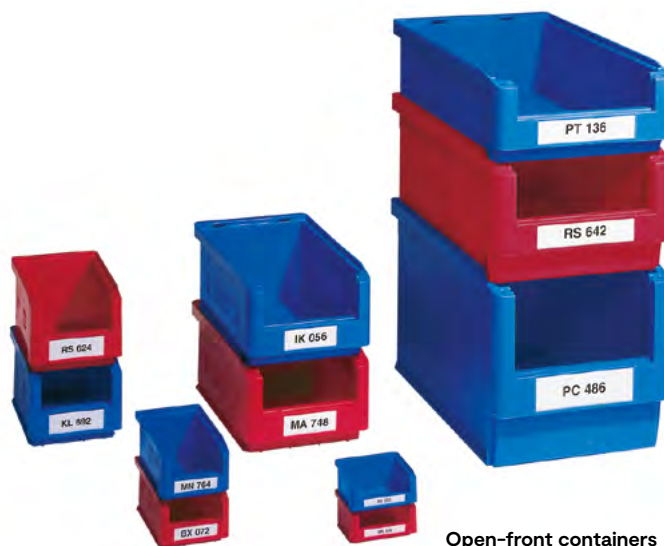

Open-front containers





Company

Color concept

Changing room & wardrobe

Workshop & factory

Office & archive





# Open-front containers

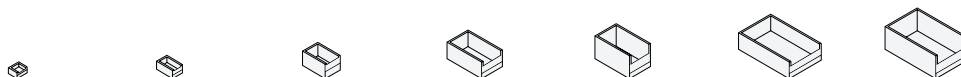

## Dimensions and version

Loose, incl. labels, available only in the specified packaging units



Size	1	2	3	4	5	6	7
Outside dimensions, HxWxD	50 x 102 x 85	75 x 103 x 160	125 x 150 x 230	145 x 210 x 350	200 x 210 x 350	145 x 315 x 500	200 x 315 x 500
Packaging unit	60 pc.	40 pc.	20 pc.	10 pc.	10 pc.	8 pc.	6 pc.
 Color red							
Order no.	8920-59153	8920-59253	8920-59353	8920-59453	8920-59553	8920-59653	8920-59753
Price							
 Color blue							
Order no.	8920-59155	8920-59255	8920-59355	8920-59455	8920-59555	8920-59655	8920-59755
Price							

**(+)** Protective label cover (1 packaging unit = 50 pc.)

& order no.	+ 8920-59105	+ 8920-59205	+ 8920-59305	+ 8920-59405	+ 8920-59505	+ 8920-59605	+ 8920-59705
& addtl. charge							

**(+)** Dust cover (1 packaging unit = 10 pc.)

& order no.	+ 8920-59101	+ 8920-59201	+ 8920-59301	+ 8920-59401	+ 8920-59501	+ 8920-59601	+ 8920-59701
& addtl. charge							

**(+)** Vertical dividers (1 packaging unit = 10 pc.)

& order no.	-	-	-	+ 8920-59402	+ 8920-59502	-	+ 8920-59702
& addtl. charge	-	-	-			-	

**(+)** Carrying bar (1 packaging unit = 10 pc.)

& order no.	-	-	-	-	-	+ 8920-59606	+ 8920-59706
& addtl. charge	-	-	-	-	-		

**(+)** Front panel (1 packaging unit = 10 pc.)

& order no.	-	+ 8920-59204	+ 8920-59304	+ 8920-59404	+ 8920-59504	+ 8920-59604	+ 8920-59704
& addtl. charge							



Protective label cover



Dust cover



Vertical divider



Carrying bar



Front panel

# Open-front container cabinets



Order no. 134013-24



Order no. 134013-21

## Dimensions and version

With hinged doors, incl. Ergo-Lock triple-bolt grip lock, shelves adjustable in 10 mm steps

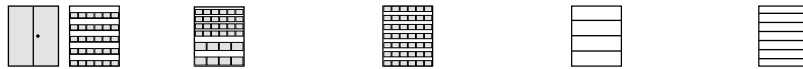

Height: 830	Interior dimensions, HxWxD	770x695x250	770x695x250	770x695x250	770x695x250	770x695x250
Width: 700	Shelves	4	5	6	3	6
Depth: 300	Open-front containers	18 x size 2 red 12 x size 2 blue	24 x size 2 red 8 x size 3 blue	42 x size 2 blue	-	-
	Order no.	134013-23	134013-24	134013-21	134013-22	134013-20
	Price					

### + Accessories

Additional shelves, corrugated rubber mat → p. 283

# Open-front container cabinets



Order no. 133944-25

## Dimensions and version

With hinged doors, incl. Ergo-Lock triple-bolt grip lock, shelves adjustable in 10 mm steps, wall mounting necessary

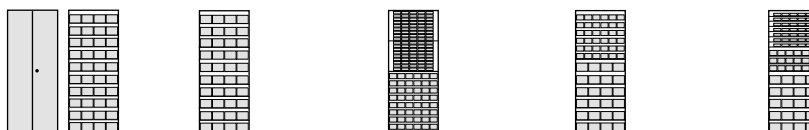

Height: 1,690	Interior dimensions, HxWxD	1620 x 695 x 250	1620 x 695 x 250	1620 x 695 x 250	1620 x 695 x 250	1620 x 695 x 250
Width: 700	Shelves	9	9	9	11	13
Depth: 300	Open-front containers	20 x size 3 red 20 x size 3 blue	12 x size 3 red 28 x size 3 blue	45 x size 1 red 45 x size 1 blue 24 x size 2 red 24 x size 2 blue	36 x size 2 red 24 x size 3 blue	18 x size 2 red 20 x size 3 blue 18 x size 1 red 18 x size 1 blue
	Order no.	133413-22	133413-28	133413-24	133413-23	133413-27
	Price					

## Occasional cabinets with open-front containers

With hinged doors, incl. Ergo-Lock triple-bolt grip lock, shelves adjustable in 10 mm steps

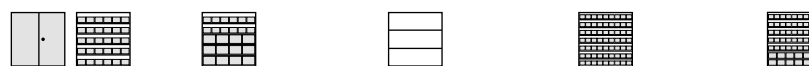

Height: 1,000	Interior dimensions, HxWxD	890 x 995 x 370	890 x 995 x 370	890 x 995 x 370	890 x 995 x 370	890 x 995 x 370
Width: 1,000	Shelves	4	4	2	6	6
Depth: 420	Open-front containers	18 x size 3 red 12 x size 3 blue	12 x size 3 red 12 x size 4 blue	-	36 x size 2 red 27 x size 2 blue	45 x size 2 red 12 x size 3 blue
	Order no.	133944-22	133944-23	133944-21	133944-24	133944-25
	Price					

## + Accessories

Corrugated rubber mat → p. 307



Order no. 133944-22

! **Open-front container sizes (HxWxD):**

- 1: 50 x 102 x 85 mm
- 2: 75 x 103 x 160 mm
- 3: 125 x 150 x 230 mm
- 4: 145 x 210 x 350 mm
- 5: 200 x 210 x 350 mm
- 6: 145 x 315 x 500 mm
- 7: 200 x 315 x 500 mm

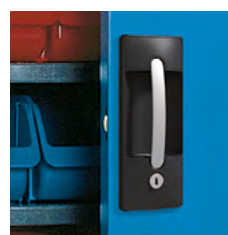

The **Ergo-Lock** grip lock (3-bolt latch) in an appealing ergonomic design

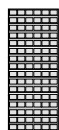
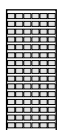

1620 x 695 x 250	1620 x 695 x 250	1620 x 695 x 250	1620 x 695 x 250
14	15	17	6
42 x size 2 red 48 x size 2 blue	48 x size 2 red 48 x size 2 blue	30 x size 1 red 30 x size 1 blue 24 x size 2 red 24 x size 2 blue	-
133413-25	133413-29	133413-210	133413-20

+ **Corrugated rubber mat for top**  
For occasional cabinets and shelves, self-adhesive



Width x depth	700 x 300	1000 x 420
& order no.	+ 134013-701	+ 133944-701
& unit price		

+ **Additional shelves**



For cabinet width	700	1000
Thickness in mm	15	25
& order no.	+ 130013-81	+ 130044-81
& unit price		



Order no. 133413-210



# Open-front container cabinets



Order no. 133113-22



Order no. 133113-23

## Dimensions and version

Hinged doors, incl. Ergo-Lock triple-bolt grip lock, shelves adjustable in 10 mm steps, wall mounting necessary

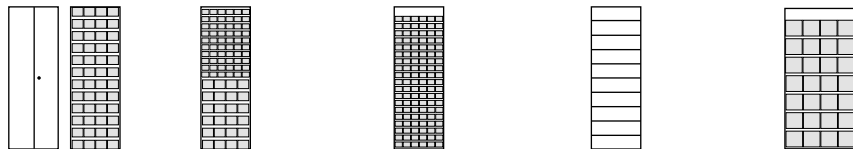

Height: 1,980	Width	700	700	700	700	1000
	Depth	300	300	300	300	420
	Interior dimensions, HxWxD	1910 x 695 x 250	1910 x 695 x 250	1910 x 695 x 250	1910 x 695 x 250	1870 x 995 x 370
	Shelves	11	15	18	9	6
	Open-front containers	24 x size 3 red 24 x size 3 blue	60 x size 2 red 24 x size 3 blue	60 x size 2 red 54 x size 2 blue	-	16 x size 5 red 12 x size 5 blue
	Order no.	133113-21	133113-22	133113-23	133113-20	133144-22
	Price					

→ Body and door color

Color concept → p. 48



Order no. 133144-23

Open-front container sizes (H x W x D):	Shelf container sizes (outside dimensions, H x W x D):
1: 50 x 102 x 85 mm	RK 3109: 90 x 117 x 300 mm
2: 75 x 103 x 160 mm	RK 3209: 90 x 234 x 300 mm
3: 125 x 150 x 230 mm	RK 3214: 140 x 234 x 300 mm
4: 145 x 210 x 350 mm	
5: 200 x 210 x 350 mm	
6: 145 x 315 x 500 mm	
7: 200 x 315 x 500 mm	

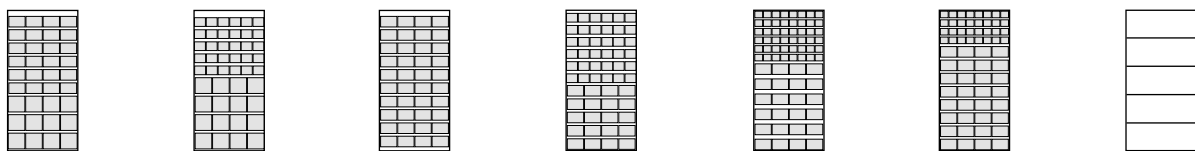

1000	1000	1000	1000	1000	1000	1000
420	420	420	420	420	420	420
1870x995x370	1870x995x370	1870x995x370	1870x995x370	1870x995x370	1870x995x370	1870x995x370
8	8	9	9	11	12	4
24 x size 4 red 12 x size 5 blue	30 x size 3 red 16 x size 5 blue	20 x size 4 red 20 x size 4 blue	30 x size 3 red 20 x size 4 blue	48 x RK 3109 blue 12 x size 4 red 12 x size 4 blue	40 x RK 3109 blue 16 x RK 3209 blue 16 x RK 3214 blue	-
133144-23	133144-25	133144-24	133144-27	133144-29	133144-28	133144-20

**+ Accessories**

Additional shelves → p. 307

# Extra-large cabinets with open-front containers

## Dimensions and version

Hinged doors on external hinges, 180° opening angle, incl. Ergo-Lock triple-bolt grip lock, shelves adjustable in 10 mm steps, for model 8931-502: 15 mm steps, wall mounting necessary

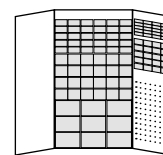
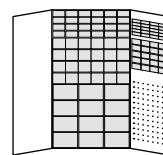
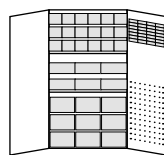
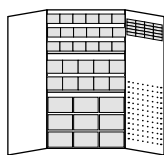

Height: 1,980	Width	1100	1100	1100	1100
	Depth	535	535	535	535
	Shelves	9	9	11	11
	Shortened shelves	7	5	8	11
	Mounting rails	5 per door	7 per door	10 per door	10 per door
	Open-front containers	40 x size 2 blue 28 x size 3 red 15 x size 4 blue 9 x size 7 red	56 x size 2 red 35 x size 3 blue 6 x size 6 red 9 x size 7 blue	40 x size 1 red 80 x size 2 blue 28 x size 3 red 20 x size 4 blue	40 x size 1 red 90 x size 2 blue 28 x size 3 red 15 x size 4 blue
	Order no.	130276-65	130276-66	130276-61	130276-62
	Price				

## Extra-large cabinets with drawers

Hinged doors on external hinges, 180° opening angle, incl. Ergo-Lock triple-bolt grip lock, load capacity per drawer: approx. 50 kg, shelves adjustable in 10 mm steps, for model 8931-501: in 15 mm steps, wall mounting necessary

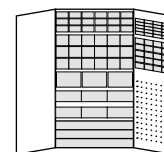
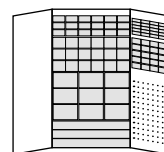
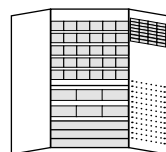
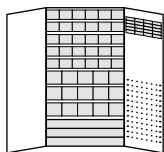

Height: 1,980	Width	1100	1100	1100	1100
	Depth	535	535	535	535
	Shelves	7	7	9	9
	Shortened shelves	6	4	8	6
	Mounting rails	5 per door	7 per door	10 per door	10 per door
	Open-front containers	40 x size 2 blue 28 x size 3 red 15 x size 4 blue	56 x size 2 red 35 x size 3 blue 6 x size 6 red	40 x size 1 red 70 x size 2 blue 21 x size 3 red 15 x size 4 blue	40 x size 1 red 70 x size 2 blue 21 x size 3 red 5 x size 4 blue 6 x size 6 red
	Drawers	3	3	3	3
	Order no.	130276-67	130276-68	130276-63	130276-64
	Price				

**+** **Drawer tidies**  
Plastic boxes for small parts,  
63 mm high



For cabinet width	1100	1200
For cabinet depth	535	500
Boxes	8 x 162 x 108 8 x 108 x 108 16 x 54 x 54 20 x 108 x 54	8 x 162 x 108 8 x 108 x 108 16 x 54 x 54 24 x 108 x 54
& order no.	+ 130076-5713	+ 8931-5713
& unit price		

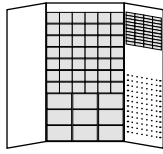
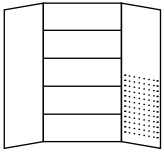

Height: 1950

1100	1200
535	500
4	9
-	7
-	10 per door
-	Each: 40 x size 1 red/blue 21 x size 3 blue 28 x size 3 red 10 x size 4 blue 5 x size 4 red
130276-613	8931-502



Order no. 8931-502

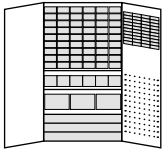

Height: 1950

1200
500
10
9
10 per door
Each: 40 x size 1 red/blue Each: 44 x size 2 red/blue 7 x size 3 red 5 x size 4 blue
3
8931-501



Order no. 130276-64

➔ **Body and door color**

Color concept → p. 48

⊕ **Accessories**

Additional drawer tidies → p. 283



# Sliding-door cabinets

## Space-saving and good for heavy loads.



To the products →



### For tools and equipment

### With viewing windows

#### The practical space-saving cabinets

- + Sturdy steel construction with high-quality enamel coating
- + Zinc-plated shelves
- + Ergonomic bow-shaped handles made of metal for easy operation
- + Push and turn cylinder lock with 2 keys and optional exchangeable cylinder
- + Easy to move sliding doors with long-lasting special casters
- + Various dimension variants, top and occasional cabinets

#### Sliding-door cabinets with a view

- + Sturdy steel construction with high-quality enamel coating
- + Zinc-plated shelves
- + Ergonomic bow-shaped handles made of metal for easy operation
- + Push and turn cylinder lock with 2 keys and optional exchangeable cylinder
- + Easy to move sliding doors with long-lasting special casters
- + Steel doors with viewing window made of acrylic glass for direct viewing
- + Various dimension variants and occasional cabinets



Loads of up to **700 kg**

## For heavy loads

### The strong cabinets with sliding doors for heavy loads

- + Sturdy steel construction with high-quality enamel coating
- + Zinc-plated shelves
- + Ergonomic bow-shaped handles made of metal for easy operation
- + Push and turn cylinder lock with 2 keys and optional exchangeable cylinder
- + Easy to move sliding doors with long-lasting special casters
- + Load capacity per shelf: 110 kg, cabinet load: 700 kg
- + Various dimension variants and occasional cabinets

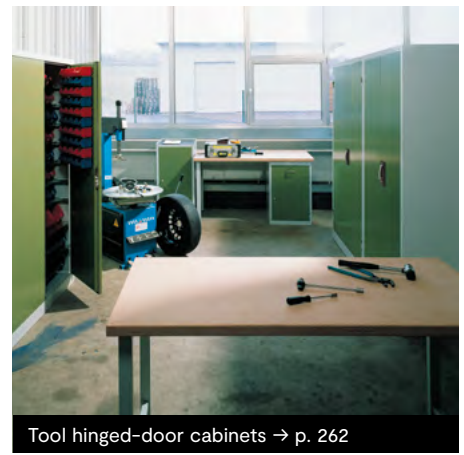

Tool hinged-door cabinets → p. 262

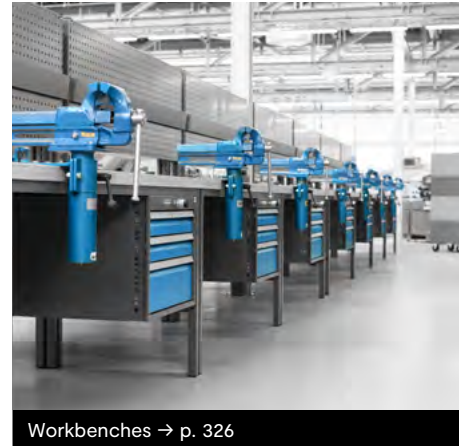

Workbenches → p. 326



Shelving → p. 340

# Sliding-door cabinets



## Features of the sliding-door cabinets:

- + Sturdy steel construction with high-quality enamel coating
- + Zinc-plated shelves
- + Ergonomic bow-shaped handles made of metal for easy operation
- + Push and turn cylinder lock with 2 keys and optional exchangeable cylinder
- + Easy to move sliding doors with long-lasting special casters
- + Highly flexible interior fittings thanks to adjustability in 15 mm steps
- + High load capacity of 70 kg per zinc-plated shelf (reinforced shelf can bear loads up to 110 kg)
- + Various dimension variants, top and occasional cabinets

## Dimensions and version

With push and turn cylinder lock

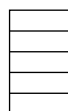

Height: 1,950	Width	1200	1200	1200
	Depth	400	500	600
	Interior dimensions, HxWxD	1840 x 1197 x 328	1840 x 1197 x 428	1840 x 1197 x 528
	Shelves	4	4	4
	Center partition	-	-	-
	Order no.	2049-00	2059-00	2069-00
	Price			

### + Additional shelves

<p>Zinc-plated</p>	Width x depth	1196 x 327	1196 x 427	1196 x 527
	& order no.	+ 2049-80	+ 2059-80	+ 2069-80
	& unit price			

### → Body and door color

Color concept → p. 48



Company

Color concept

Changing room & wardrobe

Workshop & factory

Office & archive

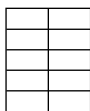
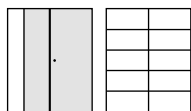

1600
400
1840 x 797 x 328*
8
1
2149-00

1600
500
1840 x 797 x 428*
8
1
2159-00

1600
600
1840 x 797 x 528*
8
1
2169-00

\*Interior dimensions refer to **one** side of the cabinet respectively (to the left or right of the center partition)

796x327
+ 2149-80

796x427
+ 2159-80

796x527
+ 2169-80

**+ Reinforced shelf**



Load capacity per shelf	<b>Approx. 110 kg</b>
Order no.	+ ...-802
Price	Double the shelf price



# Top cabinets With sliding doors.



## Dimensions and version

With push and turn cylinder lock



Height	500	500	790
Width	1200	1200	1200
Depth	400	500	400
Interior dimensions, HxWxD	450 x 1197 x 328	450 x 1197 x 428	740 x 1197 x 328
Shelves	-	-	1
Center partition	-	-	-
Order no.	2044-00	2054-00	2045-09
Price			

### Wall mount





Customer must provide wall mount for top cabinets.

→ **Body and door color**

Color concept → p. 48



Order no. 2145-09

				
790	500	500	790	790
1200	1600	1600	1600	1600
500	400	500	400	500
740x1197x428	450x1597x328	450x1597x428	740x797x328*	740x797x428*
1	-	-	2	2
-	-	-	1	1
2055-09	2144-00	2154-00	2145-09	2155-09

\*Interior dimensions refer to **one** side of the cabinet respectively (to the left or right of the center partition)

**+** Top covers, 25 mm thick  
made of MCPB, for use as occasional cabinet

	For cabinet width	1200	1200	1600	1600
	Depth	400	500	400	500
	& order no.	+ 2016-000	+ 2017-000	+ 2018-000	+ 2019-000
	& price				

**+** Top decor

Color overview → p. 52

# Occasional cabinets

## With sliding doors.

### Dimensions and version

With push and turn cylinder lock,  
incl. corrugated rubber mat for top



Width: 1,200	Height	1000	1000	1000
	Depth	400	500	600
	Interior dimensions, HxWxD	855 x 1197 x 328	855 x 1197 x 428	855 x 1197 x 528
	Shelves	1	1	1
	Order no.	2046-09	2056-09	2066-09
	Price			



Width: 1,600	Height	1000	1000	1000
	Depth	400	500	600
	Interior dimensions, HxWxD	855 x 797 x 328*	855 x 797 x 428*	855 x 797 x 528*
	Shelves	2	2	2
	Center partition	1	1	1
	Order no.	2146-09	2156-09	2166-09
	Price			

### + Additional shelves

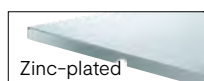

For cabinet width	1200	1200	1200	1600	1600	1600
Depth	400	500	600	400	500	600
& order no.	+ 2049-80	+ 2059-80	+ 2069-80	+ 2149-80	+ 2159-80	+ 2169-80
& unit price						

Each is for one cabinet side  
(left or right of the middle panel)

### → Body and door color

Color concept → p. 48



Order no. 2146-09



Order no. 2047-09  
& order no. 2016-000 (top decor)



1200

400

1055 x 1197 x 328

2

2047-09



1200

500

1055 x 1197 x 428

2

2057-09



1200

600

1055 x 1197 x 528

2

2067-09



1200

400

1055 x 797 x 328\*

4

1

2147-09



1200

500

1055 x 797 x 428\*

4

1

2157-09



1200

600

1055 x 797 x 528\*

4

1

2167-09

\*Interior dimensions refer to **one** side of the cabinet respectively (to the left or right of the center partition)

+ Top decor

Color overview → p. 52

MCPB = Melamine coated particle board

! All dimensions in mm, and all prices in Euros



# Sliding-door cabinets

## With viewing windows.

### Features of the sliding-door cabinets with viewing windows:

- + Sturdy steel construction with high-quality enamel coating
- + Zinc-plated shelves
- + Ergonomic bow-shaped handles made of metal for easy operation
- + Push and turn cylinder lock with 2 keys and optional exchangeable cylinder
- + Easy to move sliding doors with long-lasting special casters
- + Highly flexible interior thanks to adjustability in 15 mm steps
- + Steel doors with viewing windows made of acrylic glass (3 mm thick) for a direct view
- + Various dimension variants and occasional cabinets



The sliding doors are outfitted with smooth-running casters

### Dimensions and version

With push and turn cylinder lock

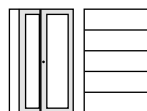

Height: 1,950	Width	1200	1200	1200
	Depth	400	500	600
	Interior dimensions, HxWxD	1840 x 1197 x 328	1840 x 1197 x 428	1840 x 1197 x 528
	Shelves	4	4	4
	Center partition	-	-	-
	Order no.	2049-055	2059-055	2069-055
	Price			

### + Additional shelves

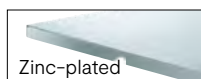

Width x depth	1196 x 327	1196 x 427	1196 x 527
& order no.	+ 2049-80	+ 2059-80	+ 2069-80
& unit price			

### → Body and door color

Color concept → p. 48



Order no. 2059-055



### Cabinets that earn money

Finding instead of searching saves time and money!

- + Simply brilliant: Thanks to the direct view of the cabinet contents, you eliminate tedious searching and cumbersome labeling systems. Better order is automatically kept in viewing window cabinets as well.
- + Die C+P cabinets with viewing windows pay for themselves after just a short period of time—and then they even make you money by saving time and reducing costs!
- + They're also perfectly suited for the implementation of modern simplification and improvement concepts such as KAIZEN or CPI.

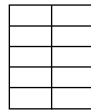
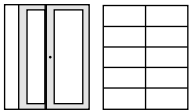

1600
400
1840 x 797 x 328*
8
1
2149-055

1600
500
1840 x 797 x 428*
8
1
2159-055

1600
600
1840 x 797 x 528*
8
1
2169-055

\*Interior dimensions refer to **one** side of the cabinet respectively (to the left or right of the center partition)

796 x 327
+ 2149-80

796 x 427
+ 2159-80

796 x 527
+ 2169-80

#### + Reinforced shelf



Load capacity per shelf	<b>Approx. 110 kg</b>
Order no.	+ ...-802
Price	Double the shelf price

# Occasional cabinets

## With viewing windows.



Order no. 2057-055

### Dimensions and version

With push and turn cylinder lock, incl. corrugated rubber mat for top



Width: 1,200	Height	1000	1000	1000
	Depth	400	500	600
	Interior dimensions, HxWxD	855 x 1197 x 328	855 x 1197 x 428	855 x 1197 x 528
	Shelves	1	1	1
	Order no.	2046-055	2056-055	2066-055
	Price			



Width: 1,600 mm	Height	1000	1000	1000
	Depth	400	500	600
	Interior dimensions, HxWxD	855 x 797 x 328*	855 x 797 x 428*	855 x 797 x 528*
	Shelves	2	2	2
	Center partition	1	1	1
	Order no.	2146-055	2156-055	2166-055
Price				

### + Additional shelves

 <p>Zinc-plated</p>	For cabinet width	1200	1200	1200	1600	1600	1600
	Depth	400	500	600	400	500	600
	& order no.	+ 2049-80	+ 2059-80	+ 2069-80	+ 2149-80	+ 2159-80	+ 2169-80
	& unit price						

Each is for one cabinet side (left or right of the middle panel)

### → Body and door color

Color concept → p. 48



Order no. 2056-055



### Cabinets that earn money

Finding instead of searching saves time and money!

- + Simply brilliant: Thanks to the direct view of the cabinet contents, you eliminate tedious searching and cumbersome labeling systems. Better order is automatically kept in viewing window cabinets as well.
- + Die C+P cabinets with viewing windows pay for themselves after just a short period of time—and they even make you money by saving time and reducing costs!
- + They're also perfectly suited for the implementation of modern simplification and improvement concepts such as KAIZEN or CPI.



1200

400

1055 x 1197 x 328

2

2047-055



1200

500

1055 x 1197 x 428

2

2057-055



1200

600

1055 x 1197 x 528

2

2067-055



1200

400

1055 x 797 x 328\*

4

1

2147-055



1200

500

1055 x 797 x 428\*

4

1

2157-055



1200

600

1055 x 797 x 528\*

4

1

2167-055

\*Interior dimensions refer to **one** side of the cabinet respectively (to the left or right of the center partition)

+ Top decor

Color overview → p. 52

MCPB = Melamine coated particle board

! All dimensions in mm, and all prices in Euros



# Sliding-door cabinets for heavy loads

## Features of the cabinets for heavy loads:

- + Sturdy steel construction with high-quality enamel coating
- + Zinc-plated shelves
- + Ergonomic bow-shaped handles made of metal for easy operation
- + Push and turn cylinder lock with 2 keys and optional exchangeable cylinder
- + Easy to move sliding doors with long-lasting special casters
- + Highly flexible interior thanks to adjustability in 15 mm steps
- + **High load capacity of each zinc-plated shelf: 110 kg**
- + **Cabinet load: 700 kg**
- + Various dimension variants and occasional cabinets

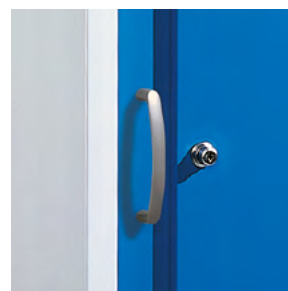

## Dimensions and version

With push and turn cylinder lock

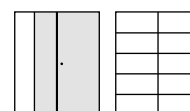
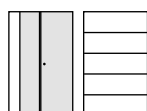

Depth: 500 Height: 1.950	Width	1200	1600
	Interior dimensions, HxWxD	1840 x 1197 x 428	1840 x 797 x 428*
	Shelves	4	8
	Center partition	-	1
	Order no.	2059-002	2159-002
	Price		

\*Interior dimensions refer to **one** side of the cabinet respectively (to the left or right of the center partition)

### + Additional shelves

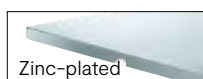

Zinc-plated	Width	1196	796
	Depth	427	427
	& order no.	+ 2059-802	+ 2159-802
	& unit price		

### → Body and door color

Color concept → p. 48



Order no. 2059-002



Loads of up to 700 kg



Order no. 2057-092

## Dimensions and version

With push and turn cylinder lock, incl. corrugated rubber mat for top

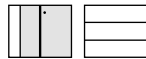

Depth: 500	Height	1000	1200	1000	1200
	Width	1200	1200	1600	1600
	Interior dimensions, HxWxD	855 x 1197 x 428	1055 x 1197 x 428	855 x 797 x 428*	1055 x 797 x 428*
	Shelves	1	2	2	4
	Center partition	-	-	1	1
	Order no.	2056-092	2057-092	2156-092	2157-092
	Price				

\*Interior dimensions refer to **one** side of the cabinet respectively (to the left or right of the center partition)

+ Top decor

Color overview → p. 52

MCPB = Melamine coated particle board

! All dimensions in mm, and all prices in Euros

# Workbenches, drawer cabinets and mobile computer, measurement and testing stations

## Versatility at its best.



### Row benches

#### The flexible modular system

- + Sturdy steel construction with high-quality enamel coating
- + Welded base made of square tube
- + Loads of up to 1,000 kg
- + Cylinder lock with 2 keys
- + Secure central locking of the drawers
- + Various dimension variants and drawer blocks

### Cabinet workbenches

#### The rugged cabinets for heavy-duty purposes

- + Sturdy steel construction with high-quality enamel coating
- + Made of square tube
- + Loads of up to 1,000 kg
- + Cylinder lock with 2 keys
- + Secure central locking of the drawers
- + Level adjustment sliders under the feet
- + Various dimension variants and drawer blocks



## Drawer cabinets

### The heavy-load pros with drawers

- + Sturdy steel construction with high-quality enamel coating
- + Recessed handle bars with labeling strips
- + Ball-bearing drawer guides with full extension slide
- + Individual anti-tilt mechanism
- + Cylinder lock with 2 keys
- + Secure central locking
- + Various dimension variants and panel heights



## Mobile cabinets

### The mobile helpers

- + Sturdy steel construction with high-quality enamel coating
- + Mobile thanks to 4x 125 mm-dia. casters, 2 of which lock
- + Cable openings in the rear panel
- + Small and large cabinet for every need
- + Large cabinet with square perforation in the rear panel for ventilation



# Row workbench series 450

## Features of the row workbenches:

- + Sturdy steel construction with high-quality enamel coating
- + Welded base made of 50x50x2 mm square tube
- + The modular principle enables flexible arrangement of the drawer cabinets or workbench legs
- + Large cabinets with usable housing height of 700 mm, doors and drawers flush with housing
- + Recessed, full-length handle bars with labeling strips and transparent cover
- + Secure central locking, combination lock system available
- + Drawers with ball guide and 100% full extension slide
- + Drawers with 50 mm panel height, 70 kg load
- + Drawers with 75 mm panel height and up, 100 kg load
- + Work tops made of 40 mm glued laminated multiplex beech, oiled
- + Delivered disassembled for easy assembly

## Dimensions and version

With cylinder lock



Depth: 750 Height: 859	Width	1000	1500	2000	1000	1500	2000	1000	1500	2000
	Description		2xbases, 1x multiplex beech top			2xbases, 1x multiplex beech top Cabinet hanging underneath: 1x150			2xbases, 1x multiplex beech top Cabinet hanging underneath: 2x150	
Order no.		4501-010	4502-010	4503-010	4501-140	4502-140	4503-140	4501-020	4502-020	4503-020
Price										



### + Small-part boxes | 24-piece

For panel height	50	100
Order no.	99003-0001	99003-0002

Price



### + Metal dividers | 8-piece

50	100	150	200	
Order no.	99003-0003	99003-0004	99003-0005	99003-0006

## Body/Frame

■ RAL 7035 light gray

The specified product order no. must be supplemented with the color specification when ordering: Body/frame always RAL 7035 light gray, fronts as per chart—please specify color no. (fronts are shown in RAL 5012 light blue in chart header)

## Available fronts

■ RAL 5012 light blue

■ RAL 3003 ruby red

■ RAL 5010 gentian blue

■ RAL 6011 reseda green

■ RAL 7016 anthracite gray

■ RAL 7035 light gray



Company

Color concept

Changing room & wardrobe

Workshop & factory

Office & archive



1500	2000	1500	2000	1500	2000
1x base, 1x multiplex beech top, 1x panel 1x150, 1x hinged door 550		1x base, 1x multiplex beech top, 1x 50, 3x100, 1x 150 & 1x200 panels		1x multiplex beech top, 1x 50, 1x100, 1x 150 & 2x200 panels (left) 1x panel (right) 1x150, 1x hinged door (right) 550	
4502-100	4503-100	4502-070	4503-070	4502-130	4503-130

**+ Additional accessories**

**Whole shelf, 25 mm thick**

**Half shelf, 25 mm thick**

**Backboard, 15 mm thick**

**Multiplex beech**

	1000	1500	2000	1500	2000	1500	2000
For workbench width							
Width	840	1350	1850	850	1350	1500	2000
Depth	550	550	550	550	550	120	120
Order no.	99003-0011	99003-0012	99003-0013	99003-0014	99003-0015	99003-0016	99003-0017
Price							

# “Small” workbenches with cabinet

## Features of the “Small” workbenches with cabinet:

- + No assembly required—workbenches are delivered fully assembled
- + Sturdy steel construction with high-quality enamel coating
- + Frame made of 40x40x2 mm square tube
- + Drawers feature ball guides
- + Recessed drawers and doors, therefore no risk of injury due to projecting handle bars
- + 100% full extension (FE) slide drawers
- + **Usable drawer dimensions: 450 x 600 mm**
- + Drawers with 50 mm panel height, 70 kg load
- + Drawers with 75 mm panel height and up, 100 kg load
- + Secure central locking, cylinder lock with two keys
- + Work top made of 40 mm glued laminated multiplex beech, oiled
- + Level adjustment sliders under the feet



Order no. 99003-0019-002



## Dimensions and version

Height: 859	Width	1500	1500	1500
Depth: 750	Description	Left: 3x200 Right: 3x100, 2x150	Left: 1xhinged door 600 with shelf Right 1x100, 1x200 & 1x300	Left: 3x100, 2x150 Right: 1 x half shelf
	Order no. (for front 5012)	99003-0018-002	99003-0019-002	99003-0020-002
	Price			

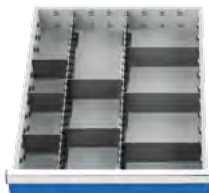
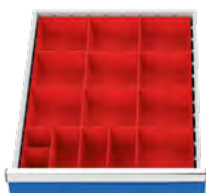

⊕ **Small-part boxes | 15-piece**

For panel height	50	100
Order no.	99003-0022	99003-0023
Price		

⊕ **Metal dividers | 10-piece**

50	100	150	200
99003-0007	99003-0008	99003-0009	99003-0010

⊕ **Metal dividers | 25-piece**

50	100	150
99003-0024	99003-0025	99003-0026



For special colors for bodies, frames or fronts, as well as special locks, please inquire on a project-by-project basis



1500	2000	2000	2000	2000
Left: 1x half shelf	Left: 2x 50, 2x 100 & 2x 150	Left: 1x 50, 1x 150 & 2x 200	Left: 4x 150	Left: 3x 100, 2x 150
Right: 1x 200, 1x hinged door 400	Right: 1 x half shelf	Right: 1x 150, 1x hinged door 450	Center: 4x 150 Right: 1x hinged door 600	Center: 3x 200 Right: 2x 75, 1x 150 & 1x 300
99003-0021-002	99003-0027-002	99003-0028-002	99003-0029-002	99003-0030-002



**+** **Workbench holder for perforated plates**  
Suitable for perforated plates on Page p. 338.

Recommendations for widths:  
1,000 mm: 2 holders  
1,500 mm: 3 holders  
2,000 mm: 3 holders

	For 1 perforated plate	For 2 tiered perforated plates
Order no.	99003-0154	99003-0155
Price		

#### Body/Frame

■ RAL 7035 light gray

The specified product order no. includes the first front color of the color chart at the end (RAL 5012 light blue, color no. -002). All other specified colors are available at no additional charge—simply change the color no. at the end of the product order no.

Available fronts	Color no.
■ RAL 5012 light blue	-002
■ RAL 3003 ruby red	-009
■ RAL 5010 gentian blue	-008
■ RAL 6011 reseda green	-003
■ RAL 7016 anthracite gray	-453
■ RAL 7035 light gray	-001



# “Medium” workbenches with cabinet

## Features of the “Medium” workbenches with cabinet:

- + No assembly required—workbenches are delivered fully assembled
- + Sturdy steel construction with high-quality enamel coating
- + Frame made of 40x40x2 mm square tube
- + Drawers feature ball guides
- + Recessed drawers and doors, therefore no risk of injury due to projecting handle bars
- + 100% full extension (FE) slide drawers
- + **Usable drawer dimensions: 600 x 600 mm**
- + Drawers with 50 mm panel height, 70 kg load
- + Drawers with 75 mm panel height and up, 100 kg load

- + Secure central locking, cylinder lock with two keys
- + Work top made of 40 mm glued laminated multiplex beech, oiled
- + Level adjustment sliders under the feet



## Dimensions and version



Height: 859	Width	1500	1500
Depth: 750	Description	Left: 2 x 75, 1 x 100, 1 x 150 & 1 x 200 Right: 1 x 150, 1 x hinged door 450	Left: 2 x 100 & 2 x 200 Right: 2 x 100 & 2 x 200
	Order no. (for front 5012)	99003-0031-002	99003-0032-002
	Price		



Height: 859	Width	2000	2000
Depth: 750	Description	Left: 1 x 150, 1 x hinged door 450 Center: 2 x shelves Right: 3 x 200	Left: 1 x 50, 1 x 150 & 2 x 200 Center: 2 x shelves Right: 2 x 75, 1 x 150 & 1 x 300
	Order no. (for front 5012)	99003-0033-002	99003-0034-002
	Price		

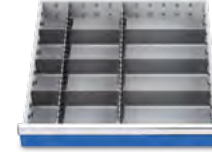
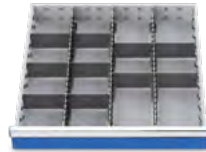

⊕ **Small-part boxes | 32-piece**

⊕ **Metal dividers | 13-piece**

⊕ **Metal dividers | 11-piece**

For panel height	50	100	50	100	150	200	100	150	200
Order no.	99003-0035	99003-0036	99003-0037	99003-0038	99003-0039	99003-0040	99003-0041	99003-0042	99003-0043
Price									

### Body/Frame

■ RAL 7035 light gray

The specified product order no. includes the first front color of the color chart at the end (RAL 5012 light blue, color no. -002). All other specified colors are available at no additional charge—simply change the color no. at the end of the product order no.

### Available fronts

Color no.

■ RAL 5012 light blue	-002
■ RAL 3003 ruby red	-009
■ RAL 5010 gentian blue	-008
■ RAL 6011 reseda green	-003
■ RAL 7016 anthracite gray	-453
■ RAL 7035 light gray	-001

# “Small” drawer cabinets

## Features of the “Small” drawer cabinets:

- + Sturdy steel construction with high-quality enamel coating
- + 100% full extension (FE) slide drawers
- + Drawers: 50 mm, 70 kg load
- + Drawers: 75 mm and up, 100 kg load
- + Ball bearing drawer guide
- + Individual anti-tilt mechanism
- + Handle bars with labeling strips for insertion
- + **Usable drawer dimensions: 450 x 600 mm**
- + Recessed drawers, therefore no risk of injury due to projecting handle bars
- + Secure central locking, cylinder lock with two keys
- + For drawer tidies, see p. 330



Height: 819	Width	555	555	555
Depth: 736	Panel heights	1x 100 & 4x 150	5x 100 & 1x 200	1x 50, 2x 75, 2x 100 & 2x 150
	Order no. (for front 5012)	99003-0044-002	99003-0045-002	99003-0046-002
	Price			



**+ Top cover**

**Multiplex beech**

Order no. 99003-0047

Price



**+ Top cover**

**Particle board coated with melamine resin**

Order no. 99003-0048

Price



**+ 3-sided metal raised edge**

**20 mm high**

Order no. 99003-0049

Price



**+ Lift truck base**

Order no. 99003-0050

Price



**+ Mobile add-on (cannot be retrofitted)**

2 x fixed casters and 2 x casters with lock, 125 mm dia. 2 x plastic push handles

Order no. 99003-0051

Price

**Body/Frame**

■ RAL 7035 light gray

The specified product order no. includes the first front color of the color chart at the end (RAL 5012 light blue, color no. -002). All other specified colors are available at no additional charge—simply change the color no. at the end of the product order no.

**Available fronts**

Color no.

■ RAL 5012 light blue	-002
■ RAL 3003 ruby red	-009
■ RAL 5010 gentian blue	-008
■ RAL 6011 reseda green	-003
■ RAL 7016 anthracite gray	-453
■ RAL 7035 light gray	-001

# “Medium” drawer cabinets

## Features of the “Medium” drawer cabinets:

- + Sturdy steel construction with high-quality enamel coating
- + Housing: powder-coated
- + 100% full extension (FE) slide drawers
- + Drawers: 50 mm, 70 kg load
- + Drawers: 75 mm and up, 100 kg load
- + Ball bearing drawer guide
- + Individual anti-tilt mechanism
- + Handle bars with labeling strips for insertion
- + **Usable drawer dimensions: 600 x 600 mm**
- + Recessed drawers, therefore no risk of injury due to projecting handle bars
- + Secure central locking, cylinder lock with two keys



Order no. 99003-0053-002

## Dimensions and version



Height: 1,019	Width	705	705	705
Depth: 736	Panel heights	2 x 100, 2 x 150 & 2 x 200	1 x 50, 2 x 100, 3 x 150 & 1 x 200	2 x 50, 2 x 75, 1 x 100, 1 x 150 & 2 x 200
	Order no. (for front 5012)	99003-0052-002	99003-0053-002	99003-0054-002
	Price			



+ Top cover

### Multiplex beech

Order no. 99003-0055

Price



+ Top cover

### Particle board coated with melamine resin

Order no. 99003-0056

Price



+ 3-sided metal raised edge

### 20 mm high

Order no. 99003-0057

Price



+ Lift truck base

Order no. 99003-0058

Price



+ Mobile add-on (cannot be retrofitted)

2 x fixed casters and 2 x casters with lock, 125 mm dia.  
2 x plastic push handles

Order no. 99003-0059

Price







## Body/Frame

 RAL 7035 light gray

The specified product order no. includes the first front color of the color chart at the end (RAL 5012 light blue, color no. -002). All other specified colors are available at no additional charge—simply change the color no. at the end of the product order no.

## Available fronts

Color no.

	RAL 5012 light blue	-002
	RAL 3003 ruby red	-009
	RAL 5010 gentian blue	-008
	RAL 6011 reseda green	-003
	RAL 7016 anthracite gray	-453
	RAL 7035 light gray	-001

# “Large” drawer cabinets

## Features of the “Large” drawer cabinets:

- + Sturdy steel construction with high-quality enamel coating
- + Housing: powder-coated
- + 100% full extension (FE) slide drawers
- + Drawers: 50 mm, 70 kg load
- + Drawers: 75 mm and up, 100 kg load
- + Ball bearing drawer guide
- + Individual anti-tilt mechanism
- + Handle bars with labeling strips for insertion
- + **Usable drawer dimensions: 900 x 600 mm**
- + Recessed drawers, therefore no risk of injury due to projecting handle bars
- + Secure central locking, cylinder lock with two keys



Order no. 99003-0061-002



1005  
1x 75, 2x 100, 1x 125,  
2x 150 & 1x 200  
99003-0060-002



1005  
2x 75, 1x 150 &  
3x 200  
99003-0061-002



1005  
2x 50, 1x 100, 4x 125 &  
1x 200  
99003-0062-002



+ Top cover

### Multiplex beech

Order no. 99003-0063

Price



+ Top cover

### Particle board coated with melamine resin

Order no. 99003-0064

Price



+ 3-sided metal raised edge

### 20 mm high

Order no. 99003-0065

Price



+ Lift truck base

Order no. 99003-0066

Price

### Body/Frame

■ RAL 7035 light gray

The specified product order no. includes the first front color of the color chart at the end (RAL 5012 light blue, color no. -002). All other specified colors are available at no additional charge—simply change the color no. at the end of the product order no.



+ Mobile add-on (cannot be retrofitted)

2 x fixed casters and 2 x casters with lock, 125 mm dia.  
2 x plastic push handles

Order no. 99003-0067

Price

### Available fronts

Color no.

■ RAL 5012 light blue	-002
■ RAL 3003 ruby red	-009
■ RAL 5010 gentian blue	-008
■ RAL 6011 reseda green	-003
■ RAL 7016 anthracite gray	-453
■ RAL 7035 light gray	-001



## Tidies for “Medium” drawer cabinets:



**(+) Small-part boxes | 24-piece**

**Comprised of: 12 boxes of size 150 x 150 mm, 4 boxes of size 75 x 150 mm & 8 boxes of size 75 x 75 mm**

For panel height	50	100
Order no.	99003-0068	99003-0069
Price		



**(+) Metal dividers | 10-piece**

**Comprised of: 2 center rails of size 600 mm & 8 partitions of size 200 mm**

For panel height	50	100	150	200
Order no.	99003-0070	99003-0071	99003-0072	99003-0073
Price				

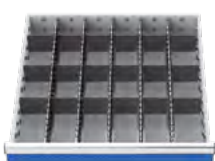

**(+) Metal dividers | 23-piece**

**Comprised of: 5 center rails of size 600 mm & 18 partitions of size 100 mm**

For panel height	50	100	150	200
Order no.	99003-0074	99003-0075	99003-0076	99003-0077
Price				



**(+) Corrugated rubber inlay**

For panel height	50 - 200
Order no.	99003-0078
Price	

## Tidies for “Large” drawer cabinets:



**(+) Small-part boxes | 40-piece**

**Comprised of: 16 boxes of size 150 x 150 mm, 8 boxes of size 75 x 150 mm & 16 boxes of size 75 x 75 mm**

For panel height	50	100
Order no.	99003-0079	99003-0080
Price		

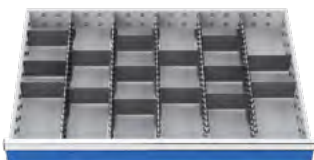

**(+) Metal dividers | 20-piece**

**Comprised of: 5 center rails of size 600 mm & 15 partitions of size 150 mm**

For panel height	50	100	150	200
Order no.	99003-0081	99003-0082	99003-0083	99003-0084
Price				

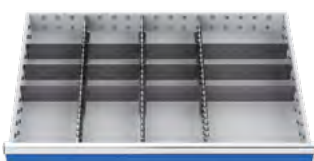

**(+) Metal dividers | 15-piece**

**Comprised of: 3 center rails of size 600 mm, 9 partitions of size 200 mm & 3 partitions of size 300 mm**

For panel height	50	100	150
Order no.	99003-0085	99003-0086	99003-0087
Price			



**(+) Corrugated rubber inlay**

For panel height	50 - 200
Order no.	99003-0088
Price	

- + Sturdy steel construction with high-quality enamel coating
- + Mobile thanks to 4x 125 mm-dia. casters, 2 of which lock
- + Cable openings in the rear panel
- + Small and large cabinet for every need
- + Large cabinet with square perforation in the rear panel for ventilation



## Dimensions and version

Depth: 500	Height	1000
	Width	530
	Description	1x hinged door 1x multiplex beech top cover, 25 mm 1x drawer, 100 mm, fully extendable, 70 kg load 1x roller base, 125 mm dia. 1x 4-socket outlet
		2x hinged doors 1x pull-out keyboard tray 1x shelf Perforated rear panel 1x slanted shelf 1x flat-screen holder with VESA screw connection 1x roller base, 125 mm dia. 1x 4-socket outlet
	Order no. (for front 5012)	99003-0089-002
	Price	99003-0090-002

### Body/Frame

■ RAL 7035 light gray

The specified product order no. includes the first front color of the color chart at the end (RAL 5012 light blue, color no. -002). All other specified colors are available at no additional charge—simply change the color no. at the end of the product order no.

### Available fronts

Color no.

■ RAL 5012 light blue	-002
■ RAL 3003 ruby red	-009
■ RAL 5010 gentian blue	-008
■ RAL 6011 reseda green	-003
■ RAL 7016 anthracite gray	-453
■ RAL 7035 light gray	-001

# Perforated plates

Perforated plate system: The right hook for every tool. They're simply mounted in the desired hole and clicked in place. The hook stays in place and doesn't wobble.

- + Clear, space-saving storage of tools, small parts and work materials
- + Rugged powder coating
- + Reinforced with binding beams

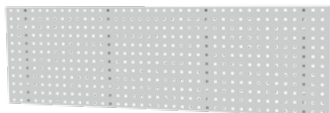

**+ Perforated plate**

**Steel plate, perforated, 10 x 10 mm beveled all around, RAL 7035 light gray perforation spacing: 38 x 38 mm**

Order no.	Dimensions	Price
99003-0150	500 x 450	
99003-0151	1000 x 450	
99003-0152	1500 x 450	
99003-0153	2000 x 450	



**+ Tool holder With straight pin**

**Ø 6 mm**

Order no.	Dimensions	Price
99003-0135	35	
99003-0136	75	
99003-0137	125	



**+ Tool holder With vertical hook end**

**Ø 6 mm**

Order no.	Dimensions	Price
99003-0098	50	
99003-0099	100	
99003-0100	150	



**+ Tool holder With slanted hook end**

**Ø 6 mm**

Order no.	Dimensions	Price
99003-0094	50	
99003-0095	100	
99003-0096	150	
99003-0097	200	



**+ Double tool holder With slanted hook end**

**Ø 6 mm**

Order no.	Dimensions	Price
99003-0103	50	
99003-0104	75	
99003-0105	150	



**+ Double tool holder With vertical hook end**

**Ø 6 mm**

Order no.	Dimensions	Price
99003-0139	35	
99003-0140	50	
99003-0141	75	
99003-0142	150	



**+ Slanted hook For nuts and socket wrench**

**Ø 6 mm**

Order no.	Dimensions	Price
99003-0138	14/40	



**+ Round holder**

Order no.	Dimensions	Price
99003-0116	65 x 25	



**+ Appliance holder**

Order no.	Dimensions	Price
99003-0117	40	
99003-0118	60	
99003-0119	80	



**+ Base plate**

Order no.	Version	Price
99003-0129	Small	
99003-0130	Large	



**+ Magnetic holder**

Order no.	Dimensions	Price
99003-0101	40	



**+ Magnets**

**Pack. unit: 10 pc.**

Order no.	Dimensions	Price
99003-0102	Ø 25	



+ **Tool lip, single, small base plate**

Order no.	Dimensions	Price
99003-0106	6	
99003-0107	10	
99003-0108	13	
99003-0109	16	
99003-0110	19	



+ **Holder for pliers**

Order no.	Dimensions	Price
99003-0143	20 x 35	
99003-0144	50 x 40	
99003-0145	75 x 50	
99003-0146	20 x 55	
99003-0147	20 x 75	



+ **Saw holder, must be ordered in pairs, packaging unit: 1 pc.**

Order no.	Version	Price
99003-0126	für 4 Sägen	



+ **Tube holder**  
Also for hoses, cables etc.

Order no.	Dimensions	Price
99003-0127	62	
99003-0128	100	



+ **Screwdriver holder**

Dimensions in mm (WxDxH): 200/390 x 30 x 40

Order no.	Version	Price
99003-0122	For 6 parts	
99003-0123	For 12 parts	



+ **Double tool clip**

Order no.	Dimensions	Price
99003-0111	6	
99003-0112	10	
99003-0113	13	
99003-0114	16	
99003-0115	19	



+ **3-compartment tool holder**

Order no.	Dimensions	Price
99003-0120	45 x 150	



+ **Wrench holder**  
Horizontal

For 8 wrenches

Order no.	Dimensions	Price
99003-0121	130/60 x 150 x 50	



+ **Storage tray**

Order no.	Dimensions	Price
99003-0148	350 x 125	
99003-0149	445 x 150	



+ **Drill bit/hexagon socket holder (various dia.)**

Dimensions in mm (WxDxH): 200/390 x 30 x 35

Order no.	Version	Price
99003-0124	For 14 parts	
99003-0125	For 28 parts	

## Hook assortments as value sets

Practical combinations (for exact combinations, see lists below)

+ **Hook assortment, 10-piece**

7x tool holders with slanted end  
2x double tool holder  
1x tool clip

Order no.	Price
99003-0131	

+ **Hook assortment, 18-piece**

5x tool holders with slanted end  
2x tool holders with vertical end  
3x double tool holders  
3x tool clips  
2x holders for pliers  
1x drill bit holder  
1x wrench holder  
1x screwdriver holder

Order no.	Price
99003-0132	

+ **Hook assortment, 28-piece**

6x tool holders with slanted end  
8x tool holders with vertical end  
6x double tool holders  
2x holders for pliers  
1x appliance holder  
1x wrench holder  
1x screwdriver holder  
1x drill bit holder  
2x saw holders

Order no.	Price
99003-0133	

+ **Hook assortment, 40-piece**

9x tool holders with slanted end  
12x tool holders with vertical end  
9x double tool holders  
3x holders for pliers  
2x appliance holder  
1x wrench holder  
1x screwdriver holder  
1x drill bit holder  
2x saw holders

Order no.	Price
99003-0134	



# Shelf systems



## File shelving

### The slot-in shelving for the binder archive

- + Fast and easy to assemble boltless system
- + Shelves adjustable in 25 mm steps
- + Load capacity per shelf: 80 kg
- + Maximum bay load: 600 kg
- + Surfaces: Available zinc-plated or in light gray RAL 7035



## Boltless shelving for standard loads

### The quick-assembly shelving for standard loads

- + Fast and easy to assemble boltless system
- + Shelves adjustable in 25 mm steps
- + Load capacity per shelf: 100 kg
- + Maximum bay load:  
1,100 kg (height: 2,000 mm)  
1,650 kg (height: 2,500 mm)
- + Surfaces: Available zinc-plated or in light gray RAL 7035



## Boltless shelving for moderately heavy loads

### The right shelving for greater demands

- + Fast and easy to assemble boltless system
- + Shelves adjustable in 25 mm steps
- + Load capacity per shelf: 150 kg
- + Maximum bay load:  
1,100 kg (height: 2,000 mm)  
1,650 kg (height: 2,500 mm)
- + Surfaces: Available zinc-plated or in light gray RAL 7035



## Boltless shelving for heavy loads

**The strong shelving for heavy-duty purposes**

- + Fast and easy to assemble boltless system
- + Shelves adjustable in 25 mm steps
- + Load capacity per shelf: 230 kg
- + Maximum bay load:  
1,650 kg (height: 2,000 mm)  
2,400 kg (height: 2,500 mm)
- + Surfaces: Available zinc-plated or in light gray RAL 7035



## Long boltless shelving

**The specialists for large and heavy stored goods**

- + Fast and easy to assemble boltless system
- + Shelves adjustable in 50 mm steps
- + Load capacity per shelf: 500/400 kg  
(shelving width: 1,700 & 2,000 mm/2,500 mm)
- + Maximum bay load: 3,000 kg
- + Surfaces: zinc-plated, particle board shelves

# Boltless file shelving

## Features of boltless file shelving:

- + Boltless shelf system using frames with diagonal braces or longitudinal braces, shelves and assembly hardware
- + Set up very quickly and easily
- + Shelf height adjustable in 25 mm steps
- + High load capacity of 80 kg per shelf with evenly distributed load
- + Bay load: 600 kg
- + Available in light gray RAL 7035, coated or zinc-plated
- + Zinc-plated version: Shelf frames are delivered dismantled
- + Coated version: Shelf frames are delivered preassembled



Order no. 99002-000012  
& 99002-000018 (cover shelf)



Diagonal brace with tightener



Shelf bracket

### Planning dimensions

**Basic shelving:** Depth + 36 mm  
Width + 56 mm

**Add-on shelving:** Depth + 36 mm  
Width + 6 mm

## Single/double basic boltless file shelving

Consisting of 2 side frames, 6 shelves for 6 binder heights, 2 diagonal braces with tightener. The double basic shelving has 2 pair of longitudinal braces.



Height: 2,200	Depth	300	300	600	600
Width: 1,000	Version	Zinc-plated	Coated	Zinc-plated	Coated
	Capacity	72 binders	72 binders	144 binders	144 binders
	Order no.	99002-000016	99002-000012	99002-000017	99002-000013
	Price				

## Single/double add-on boltless file shelving

Consisting of 1 side frame, 6 shelves for 6 binder heights, 1 diagonal brace with tightener. The double-sided add-on shelving has 2 pair of longitudinal braces.



Height: 2,200	Depth	300	300	600	600
Width: 1,000	Version	Zinc-plated	Coated	Zinc-plated	Coated
	Capacity	72 binders	72 binders	144 binders	144 binders
	Order no.	+ 99002-000014	+ 99002-000010	+ 99002-000015	+ 99002-000011
	& unit price				



Order no. 99002-000012  
& 99002-000010 (add-on shelving)  
& 2x 99002-000018 (cover shelves)



Order no. 99002-000017  
& 99002-000021 (cover shelves)



+ Fastening sets	For wall mounting	For floor attachment

**For basic shelving**

& order no.	+ 7830-704	+ 7830-706
-------------	------------	------------

& unit price

**For add-on shelving**

& order no.	+ 7830-705	+ 7830-707
-------------	------------	------------

& unit price

**! Safety information:**  
Shelving must be secured against tipping over if the height of the shelving is more than 5 times its depth.

**+ Top cover shelf**  
For dust protection, incl. shelf support

Width: 1,000	For shelf depth	300	600	300	600
	Version	Zinc-plated	Zinc-plated	Coated	Coated
	& order no.	+ 99002-000019	+ 99002-000021	+ 99002-000018	+ 99002-000020
	& unit price				



# 788 series

## Boltless shelving for standard loads.

### Features of the 788 series:

- + Attractively priced shelving for standard loads
- + Fast, easy and boltless assembly
- + High load capacity per shelf: max. 100 kg
- + Bay load: max. 1,100 kg (height: 2,000 mm)  
max. 1,650 kg (height: 2,500 mm)
- + Shelf height adjustable in 25 mm steps
- + Available surfaces: Zinc-plated  
or coated in light gray RAL 7035



Diagonal brace with tightener



Side braces, zinc-plated

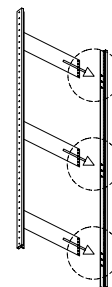

Shelf frames are supplied dismantled and can be easily fitted together  
Example: 2,500 mm

#### Planning dimensions

**Basic shelving:** Depth + 36 mm

Width + 56 mm

**Add-on shelving:** Depth + 36 mm

Width + 6 mm

All load specifications apply for shelving loaded manually with evenly distributed load.

### Basic boltless shelving

Consisting of 2 side frames, shelves (for quantity, see below), 2 diagonal braces with tightener for 2,000 heights, 4 diagonal braces with tightener for 2,500 height



Width: 1,000

Height

2000

2000

Depth

400

500

Shelves

5

5

Order no.

78820-42

78820-52

Price

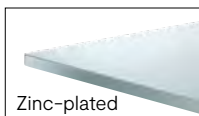

Zinc-plated

Order no.

78820-40

78820-50

Price

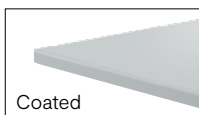

Coated

#### + Add-on boltless shelving

Consisting of 1 side frame, shelves (for quantity, see above), 1 diagonal brace with tightener for 2,000 height, 2 diagonal braces with tightener for 2,500 height (for all other dimensions, see basic boltless shelving)



Height

2000

2000

& order no.

+ 78820-43

+ 78820-53

& unit price

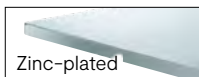

Zinc-plated

& order no.

+ 78820-41

+ 78820-51

& unit price

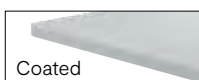

Coated

#### + Additional shelves, zinc-plated

For shelf depth

400

500

600

& order no.

+ 78842-80

+ 78852-80

+ 78862-80

& unit price



Order no. 78825-52  
& 78825-53 (add-on shelving)



High load capacity thanks to multiple edgings



Shelf bracket



Floor attachment for shelving with a height/depth ratio of >\_ 5:1.

This shelving must be secured against tipping over (wall or foot anchoring).

**+ Fastening sets**

For wall mounting

For floor attachment

**For basic shelving**

& order no.

+ 7830-704

+ 7830-706

& unit price

**For add-on shelving**

& order no.

+ 7830-705

+ 7830-707

& unit price



2000  
600  
5  
78820-62

78820-60

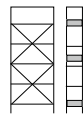

2500  
400  
6  
78825-42

78825-40

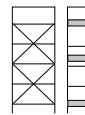

2500  
500  
6  
78825-52

78825-50

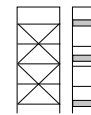

2500  
600  
6  
78825-62

78825-60



2000  
+ 78820-63

+ 78820-61

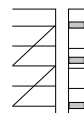

2500  
+ 78825-43

+ 78825-41

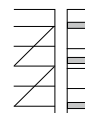

2500  
+ 78825-53

+ 78825-51

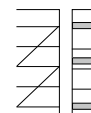

2500  
+ 78825-63

+ 78825-61

**+ Additional shelves, coated**

For shelf depth

400

500

600

& order no.

+ 78840-80

+ 78850-80

+ 78860-80

& unit price

# 78 series



## Boltless shelving for moderately heavy loads.

### Features of the 78 series:

- + Attractively priced shelving for moderately heavy loads
- + Fast, easy and boltless assembly
- + High load capacity per shelf: max. 150 kg
- + Bay load: max. 1,100 kg (height: 2,000 mm)  
max. 1,650 kg (height: 2,500 mm)
- + Shelf height adjustable in 25 mm steps
- + Available surfaces: Zinc-plated or coated in light gray RAL 7035



Diagonal brace with tightener



Side braces, zinc-plated

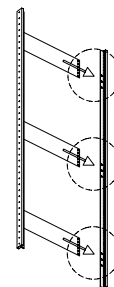

Shelf frames are supplied dismantled and can be easily fitted together  
Example: 2,500 mm

**Planning dimensions**  
**Basic shelving:** Depth + 36 mm  
 Width + 56 mm  
**Add-on shelving:** Depth + 36 mm  
 Width + 6 mm

All load specifications apply for shelving loaded manually with evenly distributed load.

### Basic boltless shelving

Consisting of 2 side frames, shelves (for quantity, see below), 2 diagonal braces with tightener for 2,000 height, 4 diagonal braces with tightener for 2,500 height



Width: 1,000

Height

2000

2000

Depth

400

500

Shelves

5

5

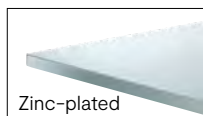

Order no.

99002-000056

99002-000058

Price

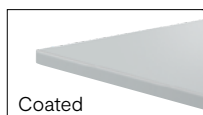

Order no.

99002-000055

99002-000057

Price

#### + Add-on boltless shelving

Consisting of 1 side frame, shelves (for quantity, see above), 1 diagonal brace with tightener for 2,000 height, 2 diagonal braces with tightener for 2,500 height (for all other dimensions, see basic boltless shelving)



Height

2000

2000

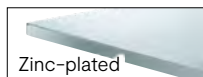

& order no.

+ 99002-000032

+ 99002-000034

& unit price

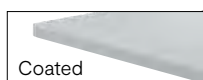

& order no.

+ 99002-000031

+ 99002-000033

& unit price

#### + Additional shelves, zinc-plated

For shelf depth

400

500

600

& order no.

+ 99002-000001

+ 99002-000002

+ 99002-000003

& unit price



Order no. 99002-000058  
& 2x 99002-000034 (add-on shelving units)



Floor attachment for shelving with a height/ depth ratio of  $>_{-} 5:1$ .

This shelving must be secured against tipping over (wall or foot anchoring).

**+ Fastening sets**

For wall mounting

For floor attachment

**For basic shelving**

& order no.

+ 7830-704

+ 7830-706

& unit price

**For add-on shelving**

& order no.

+ 7830-705

+ 7830-707

& unit price



2000

600

5

99002-000060

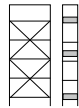

2500

400

6

99002-000068



2500

500

6

99002-000070

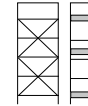

2500

600

6

99002-000072

99002-000059

99002-000067

99002-000069

99002-000071



2000

+ 99002-000036

+ 99002-000035



2500

+ 99002-000044

+ 99002-000043

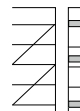

2500

+ 99002-000046

+ 99002-000045

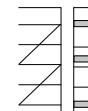

2500

+ 99002-000048

+ 99002-000047

**+ Additional shelves, coated**

For shelf depth

400

500

600

& order no.

+ 99002-000022

+ 99002-000023

+ 99002-000024

& unit price



# 7800 series

## Boltless shelving for heavy loads.

### Features of the 7800 series:

- + Fast, easy and boltless assembly
- + Sturdy T-frames for shelves
- + High load capacity per shelf: max. 230 kg
- + Bay load: max. 1,650 kg (height: 2,000 mm)  
max. 2,400 kg (height: 2,500 mm)
- + Shelf height adjustable in 25 mm steps
- + Shelves with system perforations in 50 mm steps for retroactive fitting of system accessories (e.g. compartment dividers)
- + Available surfaces: Zinc-plated or coated in light gray RAL 7035

<b>Planning dimensions</b>	
<b>Basic shelving:</b>	<b>Depth + 36 mm</b>
	<b>Width + 56 mm</b>
<b>Add-on shelving:</b>	<b>Depth + 36 mm</b>
	<b>Width + 6 mm</b>



Order no. 7820-50

All load specifications apply for shelving loaded manually with evenly distributed load.

### Basic boltless shelving



Consisting of 2 side frames, 4 shelves, 2 diagonal braces with tightener for 2,000 height, 4 diagonal braces with tightener for 2,500 height

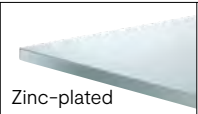
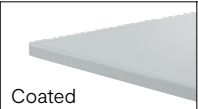

Width: 1,000	Height	2000	2000
	Depth	400	500
 Zinc-plated	Order no.	7820-42	7820-52
	Price		
 Coated	Order no.	7820-40	7820-50
	Price		

**+ Add-on boltless shelving**  
Consisting of 1 side frame, 4 shelves, 1 diagonal brace with tightener for 2,000 height, 2 diagonal braces with tightener for 2,500 height (for all other dimensions, see basic boltless shelving)

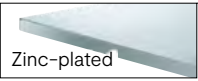

 Zinc-plated	Height	2000	2000
	& order no.	+ 7820-43	+ 7820-53
 Coated	& order no.	+ 7820-41	+ 7820-51
	& unit price		

**+ Additional shelves, zinc-plated**

For shelf depth	400	500	600
& order no.	+ 7842-80	+ 7852-80	+ 7862-80
& unit price			



Diagonal brace with tightener



Shelf bracket



Floor attachment for shelving with a height/depth ratio of  $>_{-} 5:1$ .

This shelving must be secured against tipping over (wall or foot anchoring).

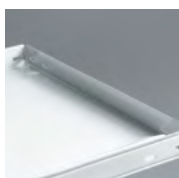

High load capacity thanks to multiple edgings

**(+) Fastening sets**

For wall mounting

For floor attachment

**For basic shelving**

& order no.	+ 7830-704	+ 7830-706
& unit price		

**For add-on shelving**

& order no.	+ 7830-705	+ 7830-707
& unit price		

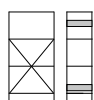

2000  
600  
7820-62

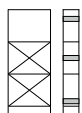

2500  
400  
7825-42

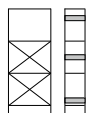

2500  
500  
7825-52

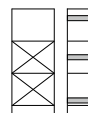

2500  
600  
7825-62

7820-60

7825-40

7825-50

7825-60



2000  
+ 7820-63

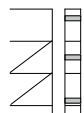

2500  
+ 7825-43

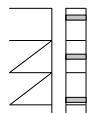

2500  
+ 7825-53

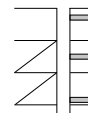

2500  
+ 7825-63

+ 7820-61

+ 7825-41

+ 7825-51

+ 7825-61

**(+) Additional shelves, coated**

For shelf depth	400	500	600
& order no.	+ 7840-80	+ 7850-80	+ 7860-80
& unit price			

# Long boltless shelving systems

## For large and heavy loads.

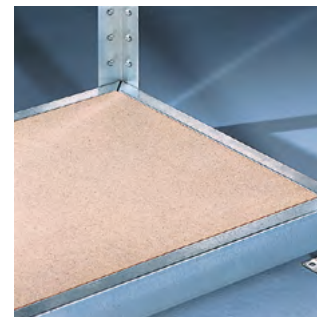

Particle board shelf

**! Safety information:**  
Shelving must be secured against tipping over if the height of the shelving is more than 5 times its depth.

### Features of long boltless shelving:

- + Fast, easy and boltless assembly
- + Complete shelf unit with 4 particle board shelves
- + Basic design allows for variable positioning options
- + Shelf level height adjustable in 50 mm steps
- + Shelf load capacity of shelf widths of 1,700 & 2,000 = up to 500 kg, 2,500 mm = up to 400 kg
- + Bay load for shelf widths of 1,700 & 2,000 = up to 3,000 kg, 2,500 mm = up to 2,800 kg
- + Horizontal and vertical stepped beams
- + Circumferential edge protection
- + 2 binding beams under every shelf
- + **Surface of profiles and beams zinc-plated**
- + Metal insertable foot
- + Fastening to the floor possible
- + All load specifications apply for shelving loaded manually with an evenly distributed load.

### Long boltless shelving with particle board shelves

Consisting of 4 support profiles, 8 horizontal stepped beams, 8 vertical stepped beams, 8 A-binding beams, 4 feet, 4 shims, 4 19 mm particle boards

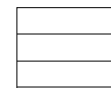

Height: 1,970	Width	1700	1700	1700	2000	2000	2000	2500	2500	2500
	Depth	400	600	800	400	600	800	400	600	800
	Order no.	781120-40	781120-60	781120-80	781220-40	781220-60	781220-80	781320-40	781320-60	781320-80
	Price									

Height: 2,470	Order no.	781125-40	781125-60	781125-80	781225-40	781225-60	781225-80	781325-40	781325-60	781325-80
	Price									

Height: 2,970	Order no.	781130-40	781130-60	781130-80	781230-40	781230-60	781230-80	781330-40	781330-60	781330-80
	Price									

**+ Additional untreated particle boards** 

& order no.	+ 781140-80	+ 781160-80	+ 781180-80	+ 781240-80	+ 781260-80	+ 781280-80	+ 781340-80	+ 781360-80	+ 781380-80
& unit price									



Order no. 781120-40







To the products →

# Office & archive

At C + P, you'll find the right cabinet for every application. Choose from a wide selection of cabinet types ranging from hinged-door, sliding-door and tambour cabinets to glass door cabinets and cabinets with drawers, for filing or for a multi-drawer cabinet.

With a variety of practical interior fittings, your C + P cabinet can be individually designed for new storage and organization needs at any time.

Add to this a competent range of lounge furniture, tables, chairs, storage space near the workstation, caddies and accessories for contemporary office furniture.

## Cabinet and filing systems



# 356

Hinged-door cabinets  
Acurado | Asisto | Certos (flame-resistant)



# 386

Sliding-door cabinets  
Acurado | Asisto

## Office furniture & accessories



# 440

Counters and lounge furniture



# 446

Tables



# 400

Tambour cabinets  
Omnispace | Asisto



# 414

Drawer and filing cabinets  
Acurado | Asisto | 7000 series



# 454

Around the desk



# 460

Chairs and stools



# 470

Cabinets, pedestals and caddies



# Hinged-door cabinets

## Sturdy and long-lasting.



### Acurado series

#### The favorably priced cabinets for classic filing

- + Sturdy steel construction with high-quality enamel coating
- + With sliders for floor protection as standard
- + Shelves, coated light gray
- + Ergo-Lock grip lock (3-bolt) with 2 keys and optional exchangeable cylinder
- + Doors on bolt hinges, door opening angle of approx. 110°
- + Complete product line (different dimension variants and interior fittings for every requirement)

### Asisto series

#### The attractive steel cabinets and shelving for any office

- + Sturdy steel construction with high-quality enamel coating
- + Appealing design thanks to narrow edges
- + Sliders for floor protection, as standard with level adjustment, adjustable from inside
- + Metal cabinet handles, matt nickel-plated
- + Shelves, coated black gray
- + 3-bolt safety lock with exchangeable cylinder, 2 keys
- + Hinged doors with approx. 225° door opening angle
- + Doors with wood decor fronts as standard, also available in steel or as glass doors
- + Complete product line (different dimension variants and interior fittings for every requirement)



## Certos series (flame-resistant)

**The double-walled cabinets with protection against fires and attempted burglary**

- + Double-walled, sturdy steel construction with special insulating plates between the walls and high-quality enamel coating
- + Protection against minor fires and attempted burglary
- + Increased protection against burglary thanks to burglar-proof door design on the side and sturdy door locks
- + With sliders for floor protection as standard
- + Shelves, coated light gray
- + Double-bit safety lock with five-bolt bolt lock system, with 2 keys
- + Doors on external sturdy bolt hinges, convenient door opening angle of approx. 180°
- + Optional electronic code lock
- + Complete product line (various heights and dimension variants for every requirement)



Sliding-door cabinets → p. 386



Tambour cabinets → p. 400

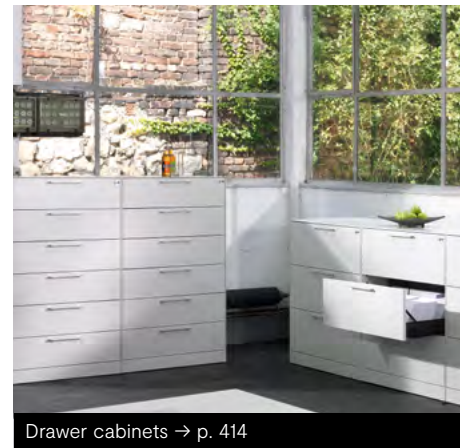

Drawer cabinets → p. 414

# The patented Ergo-Lock from C+P



Outstanding operating safety, wear resistance and an attractive appearance characterize the patented “Ergo-Lock” grip lock from C+P. The **“simply push shut to close”** feature in particular already makes the work of hundreds of thousands of users easier—and soon yours, too!

## Features of the Ergo-Lock:

- + **High-quality appearance—current and contemporary**  
Fits in with any room and gives your cabinet a distinctive look.
- + **Patented “simply push shut to close” mechanism**  
Neatly close a cabinet, even if your hands are full—only from C+P.
- + **Exchangeable cylinder, subsequent replacement, simultaneous locking—it’s all possible!**  
Remain open to future change and safeguard the security of your investment.
- + **Suitable locking systems with PIN code or transponder with the same appearance.**  
Use a PIN code or transponder instead of a key with the same design if required for security purposes. As a complete, electronic offline lock, the Ergo-Lock offers full state-of-the-art features.



Whether you use it as a key lock or with PIN codes or transponders, the Ergo-Lock product range offers the right system to suit every requirement.



Opt for security and access control to suit your particular needs:



### Mechanical locking system

- + 2 keys per lock
- + Standard design for all Acurado hinged-door cabinets
- + Also easy and convenient to operate with gloves



### PIN code lock

- + Motorized locking bolt
- + 4 digits
- + 4- to 8-digit codes possible
- + Optical function feedback (green/red)
- + Master key code
- + Usage range: +5 to +40°C
- + Operated with 2 standard AA batteries (alkaline)
- + Batteries last for approx. 30,000 openings or approx. 3 years

Order no.	8900-750
-----------	----------

Price	
-------	--



### RFID transponder lock

- + Motorized locking bolt
- + Transponder type: MIFARE® DESFire®
- + Can be integrated into existing access control systems
- + USB programming interface
- + Optical function feedback (green/red)
- + Easy operation with programmable user and master cards, as well as a service card
- + Management software also available as an option
- + Usage range: +5 to +40°C
- + Operated with 2 standard AA batteries (alkaline)
- + Batteries last for approx. 30,000 openings or approx. 3 years

Order no.	8900-740
-----------	----------

Price	
-------	--

	On request
--	------------



# Acurado

## Hinged-door cabinets.

### Features of the hinged-door cabinets:

- + Sturdy steel construction with high-quality enamel coating
- + Wide range of different dimensions for any application
- + With sliders for floor protection as standard
- + Shelves, coated light gray
- + Improved operating safety, wear resistance and an attractive ergonomic appearance thanks to the Ergo-Lock grip lock (3-bolt latch) in black with 2 keys
- + Doors on bolt hinges, door opening angle of approx. 110°
- + Door reinforcement for high stability
- + Highly flexible interior fitting options thanks to adjustability in 15 mm steps
- + Interesting range of counter and top solutions as well as shelving
- + High load capacity of 70 kg per shelf, reinforced shelf can bear loads up to 110 kg, for reinforcement see page 365



Order no. 9260-000



- + **Ergo-Lock grip lock**  
Improved operating safety, wear resistance and an attractive appearance thanks to the grip lock (3-bolt latch) in black with 2 keys—the door can be closed simply by squeezing the grip lock

To Ergo-Lock → p. 358

### Dimensions and version

With **Ergo-Lock triple-bolt grip lock**



Height: 1,950	Width	500	500	700	700
	Depth	400	500	400	500
	Interior dimensions, H x W x D	1840 x 498 x 353	1840 x 498 x 453	1840 x 698 x 353	1840 x 698 x 453
	Shelves	4	4	4	4
	Order no.	9234-000	9235-000	9236-000	9237-000
	Price				

- + **Additional shelves**  
Coated steel, light gray, in special color (project specific) on request

	Width x depth	497 x 352	497 x 452	697 x 352	697 x 452
	& order no.	+ 1034-80	+ 1035-80	+ 1036-80	+ 1037-80
	& unit price				

- + **Underframes made of square tube, 150 mm high, adjustable level**  
Black gray RAL 7021, other colors on request

	Width x depth	-	-	-	-
	& order no.	-	-	-	-
	& unit price				

- **Body and door color**

Color concept → p. 48

- + **Reinforced shelf**

Selection → p. 372



Company

Color concept

Changing room & wardrobe

Workshop & factory

Office & archive

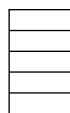
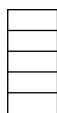
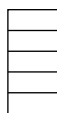
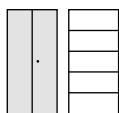

930
400
1840x928x353
4
9260-000

930
500
1840x928x453
4
9280-000

930
600
1840x928x553
4
9290-000

1200
400
1840x1198x353
4
9460-000

1200
500
1840x1198x453
4
9480-000

1200
600
1840x1198x553
4
9490-000

925x352
+ 1040-80

925x452
+ 1050-80

925x552
+ 1051-80

1195x352
+ 9360-80

1195x452
+ 1060-80

1195x552
+ 1061-80

930x400
+ 9964-00

930x500
+ 9984-00

930x600
+ 9994-00

1200x400
+ 2027-00

1200x500
+ 2028-00

1200x600
+ 2033-00

**+ Accessories**

Hanging frames, binder supports and locks → p. 372

# Acurado

## Office bookcases.



Order no. 9160-000

### Dimensions and version

Office bookcases are cabinets without doors and with shelves



Height: 1,950	Width	500	500	700	700
	Depth	400	500	400	500
	Interior dimensions, H x W x D	1840 x 498 x 353	1840 x 498 x 453	1840 x 698 x 353	1840 x 698 x 453
	Shelves	4	4	4	4
	Order no.	9134-000	9135-000	9136-000	9137-000
	Price				

**+ Additional shelves**  
Coated steel

	Width x depth	497 x 352	497 x 452	697 x 352	697 x 452
	& order no.	+ 1034-80	+ 1035-80	+ 1036-80	+ 1037-80
	& unit price				

**+ Underframes made of square tube, 150 mm high, adjustable level**  
Black gray RAL 7021, other colors on request

	Width x depth	-	-	-	-
	& order no.	-	-	-	-
	& unit price				

**→ Body color**

Color concept → p. 48

**+ Reinforced shelf**

Selection → p. 372



Company

Color concept

Changing room & wardrobe

Workshop & factory

Office & archive

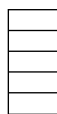
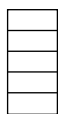

930
400
1840x928x353
4
9160-000

930
500
1840x928x453
4
9180-000

930
600
1840x928x553
4
9190-000

1200
400
1840x1198x353
4
9360-000

1200
500
1840x1198x453
4
9380-000

925x352
+ 1040-80

925x452
+ 1050-80

925x552
+ 1051-80

1195x352
+ 9360-80

1195x452
+ 1060-80

930x400
+ 9964-00

930x500
+ 9984-00

930x600
+ 9994-00

1200x400
+ 2027-00

1200x500
+ 2028-00

**+ Accessories**

Hanging frames, binder supports and locks → p. 372



**+ More file shelving**

Selection → p. 372

! All dimensions in mm, and all prices in Euros



# Acurado

## Hinged-door cabinets.



Order no. 9260-100

### Dimensions and version

With different interior fittings

With **Ergo-Lock** triple-bolt grip lock

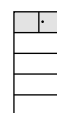
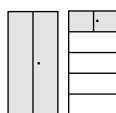

Height: 1,950	Depth	400	500
Width: 930	Interior dimensions, HxWxD	1840 x 928 x 353	1840 x 928 x 453
	Shelves	3	3
	Two-door security compartment, HxWxD	1 335 x 755 x 335	1 335 x 755 x 435
	Description	Security compartment with cylinder lock	Security compartment with cylinder lock
	Order no.	9260-100	9280-100
	Price		

### + Additional shelves

Coated steel (standard)

 <p>Steel shelves</p>	Width x depth	925 x 352	925 x 452
	& order no.	+ 1040-80	+ 1050-80
	& unit price		

### → Body and door color

Color concept → p. 48



Order no. 9280-30



Order no. 9280-088

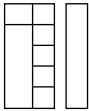

400
1840 x 375 x 350
4
-
Storage shelf with extendable coat rack rail (without coat hangers) on the left, coat rack section: approx. 550 mm wide
9260-30

500
1840 x 459 x 450
4
-
Storage shelf with coat rack rail (without coat hangers) on left, central partition
9280-30

500
1840 x 928 x 453
-
-
Full-length storage shelf on the inside with coat rack rail (without coat hangers)
9280-088

375 x 349 (additional shelf for <b>right</b> side for 9260-30)
+ 1040-38

459 x 449 (additional shelf for <b>right</b> side for 9280-30)
+ 1050-38

**+ Reinforced shelf**

Load capacity per shelf	110 kg
& order no.	+ ...-802
Price	Double the shelf price

**+ Accessories**

Hanging frames, binder supports and locks → p. 372

# Acurado

## Office cabinets and bookcases.



Order no. 9260-410



Order no. 9160-600

### Dimensions and version

Office cabinets with suspension bars and compartments with Ergo-Lock triple-bolt grip lock

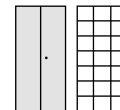
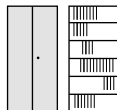

Height: 1,950	Depth	400	400
Width: 930	Description Dimensions, HxWxD	6 suspension bars (for Elba/Leitz)	21 compartments 240 x 280 x 352
	Interior dimensions, HxWxD	1840 x 928 x 353	1840 x 928 x 353
	Order no.	9260-600	9260-410
	Price		

→ Body and door color

Color concept → p. 48



## Dimensions and version

**Office bookcases** with suspension bars and compartments  
Office bookcases are cabinets without doors with rear panel and shelves in light gray

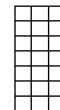

Height: 1,950	Depth	400	400
Width: 930	Description	6 suspension bars	21 compartments
	Interior dimensions, HxWxD	1840 x 928 x 353	1840 x 928 x 353
	Order no.	9160-600	9160-410
	Price		

### + Additional shelves

Selection → p. 372

### + Accessories

Selection → p. 372



# Acurado

## Top cabinets and bookcases.



Order no. 9264-000/9464-00

### Dimensions and version

**Top cabinets with Ergo-Lock**  
triple-bolt grip lock, incl. accessories for mounting to underbench cabinet



Height	500	500	500	500	500	500
Width	930	930	930	1200	1200	1200
Depth	400	500	600	400	500	600
Shelves	-	-	-	-	-	-
Binder heights	1	1	1	1	1	1
Interior dimensions, HxWxD	440x928x353	440x928x453	440x928x553	440x1198x353	440x1198x453	440x1198x553
Order no.	9264-000	9284-000	9294-000	9464-000	9484-000	9494-000
Price						

**+ Top cabinets, simultaneous locking**

& order no. + 8900-7211  
& addtl. charge

### Dimensions and version

**Top bookcases** incl. accessories for mounting to underbench cabinet



Height	500	500	500	500
Width	930	930	1200	1200
Depth	400	500	400	500
Shelves	-	-	-	-
Binder heights	1	1	1	1
Interior dimensions, HxWxD	440x928x353	440x928x453	440x1198x353	440x1198x453
Order no.	9164-000	9184-000	9364-000	9384-000
Price				

→ Customer must provide wall mounting for top cabinets and bookcases

→ **Body and door color**

Color concept → p. 48

**+ Accessories**

Binder supports and locks → p. 372



Order no. 9165-000



790	790	790	790	790	790
930	930	930	1200	1200	1200
400	500	600	400	500	600
1	1	1	1	1	1
2	2	2	2	2	2
730 x 928 x 353	730 x 928 x 453	730 x 928 x 553	730 x 1198 x 353	730 x 1198 x 453	730 x 1198 x 553
9265-000	9285-000	9295-000	9465-000	9485-000	9495-000

+ 8900-7211



790	790	790	790
930	930	1200	1200
400	500	400	500
1	1	1	1
2	2	2	2
730 x 928 x 353	730 x 928 x 453	730 x 1198 x 353	730 x 1198 x 453
9165-000	9185-000	9365-000	9385-000

**+ Additional shelves**

Coated steel (standard), only possible with cabinet/bookcase height of 790 mm

<p>Steel shelves</p>	For cabinets (WxD)	930 x 400	930 x 500	930 x 600	1200 x 400	1200 x 500	1200 x 600
	Width x depth	925 x 352	925 x 452	925 x 552	1195 x 352	1195 x 452	1195 x 552
	& order no.	+ 1040-80	+ 1050-80	+ 1051-80	+ 9360-80	+ 1060-80	+ 1061-80
	& unit price						

# Acurado

## Occasional and counter cabinets/shelving.



Order no. 9267-1200



Order no. 9286-1200  
& 1125-110 (steel top cover)

### Dimensions and version

**Occasional and counter cabinets** with MCPB top, 25 mm thick, with **Ergo-Lock** triple-bolt grip lock



Height	1000	1000	1000	1000
Width	930	930	1200	1200
Depth	400	500	400	500
Shelves	1	1	1	1
Binder heights	2	2	2	2
Interior dimensions, HxWxD	855 x 928 x 353	855 x 928 x 453	855 x 1198 x 353	855 x 1198 x 453
Order no.	9266-1200	9286-1200	9466-1200	9486-1200
Price				

**Occasional and counter shelving** with MCPB top, 25 mm thick



Order no.	9166-1200	9186-1200	9366-1200	9386-1200
Price				

**+ Alternative top covers**  
Instead of MCPB top



Width	930	930	1200	1200
Depth	400	500	400	500
& order no.	+ 1124-110	+ 1125-110	+ 2016-110	+ 2017-110
& addtl. charge				

→ **Body and door color**

Color concept → p. 48

→ **Top decor**

Color concept → p. 52



Company

Color concept

Changing room & wardrobe

Workshop & factory

Office & archive

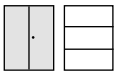

1200
930
400
2
3
1055 x 928 x 353
9267-1200



1200
930
500
2
3
1055 x 928 x 453
9287-1200



1200
1200
400
2
3
1055 x 1198 x 353
9467-1200



1200
1200
500
2
3
1055 x 1198 x 453
9487-1200



9167-1200
-----------



9187-1200
-----------



9367-1200
-----------



9167-1200
-----------

**+** Under frame 150 mm high, made of square tube, adjustable level. Black gray RAL 7021, other colors on request

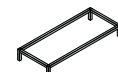
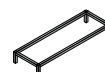

Width	930	930	1200	1200
Depth	400	500	400	500
& order no.	+ 9964-00	+ 9984-00	+ 2027-00	+ 2028-00
& price				

**+** Additional accessories

Binder supports and locks → p. 372



# Acurado

## Accessories for hinged-door cabinets.

### Additional shelves

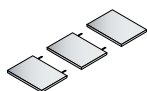

For cabinets	91/9260-410	9260-30	9280-30	Shelf support set Zinc-plated, pack. unit = 20 pc.
Cabinet dimensions, WxD	930 x 400	930 x 400	930 x 500	
	The vertical partitions of the cabinets are permanently installed. The <b>horizontal intermediate shelves</b> are supported on both sides and can only be adjusted vertically together. Additional shelves are supplied loose. <b>With front edging</b>	<b>Filing section</b> Shelf for right side	<b>Filing section</b> Shelf for right side	
Order no.	1040-49	1040-38	1050-38	1118-00-20
Price				

### Reinforced shelf

Load capacity per shelf	110 kg
& order no.	+ ...-802
Price	Double the shelf price

### Hanging frame

Fully extendable, on ball bearings, with adjustable dividers, including anti-tilt mechanism, cannot be retrofitted, color: light gray RAL 7035

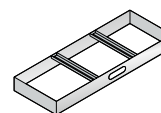
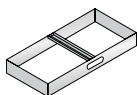

For cabinet width	930	930	1200	1200
For cabinet depth	400	500	400	500
Inner useful depth	328	328	328	328
Rows	2-row		3-row	
For files	DIN A4	DIN A4	DIN A4	DIN A4
Order no.	1040-811	1050-811	9360-811	1060-811
Price				

### Divider

Single, for hanging frame

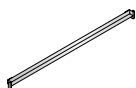

Inner useful depth	328	400
For files	DIN A4	EDP
Order no.	1000-841	1000-842
Price		



Order no. 1050-811

## Suspension bars

(Suspension bars from other systems on request)

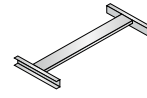
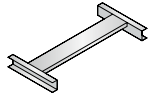

System	Elba/Leitz			Zippel		
For cabinet width	930	930	1200	930	930	1200
For cabinet depth	400	500	500	400	500	500
Inner useful width	848	848	1118	848	848	1118
Order no.	1040-82	1050-82	1060-82	1040-83	1050-83	1060-83
Price						

## Binder supports

Attachable, with 2-fold edging, suitable for all shelves

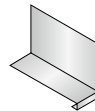

Height	100	200
Width x depth	100 x 230	100 x 270
Order no.	4221-25	4222-25
Price		



## Shelf with coat rack rail

Includes holder below the storage shelf (including storage shelf, possible from 500 mm exterior cabinet depth only), without coat hangers

Order no.	...-88
Price	On request



## Keys and locks: Ergo-Lock



	Ergo-Lock with 2 keys	Ergo-Lock with master key system without security certificate	Master key for this	Ergo-Lock with simultaneous locking	Single/spare key	Additional charge for lock with lock no. upon request (longer delivery times)	Single/spare key for security compartment
Order no.	8900-721	8900-723	8900-7131	8900-7211	0004-11	...-...99	0006-50
Price						On request	

## Other additional charges

# Asisto

## The strength and flexibility of steel in the office.

Asisto from C + P is a leading product in all areas of modern office furniture and also offers added value that is “as strong as steel” and that you can only get from C + P. The Asisto cabinets with the innovative steel body stand out thanks to their technology, design and price-performance ratio. Asisto is the intelligent complete range from the market leader in steel furniture.

### Features of Asisto hinged-door cabinets:

- + Sturdy steel construction with high-quality enamel coating
- + Appealing design thanks to narrow edges which you can only achieve with intelligently manufactured steel bodies
- + Excellent stability and suitability for moving thanks to Asisto steel body (with useful magnetic surfaces on the side)
- + Sliders for floor protection, as standard with level adjustment, adjustable from inside
- + Metal cabinet handles, matt nickel-plated
- + Shelves, coated black gray
- + 3-bolt safety lock with exchangeable cylinder, 2 keys
- + Hinged doors with approx. 225° door opening angle
- + Different fronts (steel, wood and clear glass) and tops can be matched to the steel body
- + Highly flexible interior fitting options thanks to adjustability in 15 mm steps
- + High load capacity of 70 kg per shelf
- + MCPB tops, 25 mm thick, for cabinets up to 1,635 mm in height



All units feature the narrow 6 mm edge that is characteristic for the Asisto cabinet system



The standard Asisto handles are matt nickel-plated and continue the elegant style of this product line



The adjustable hinges (opening angle of approx. 225°) are extra flat, thus allowing even better access to the cabinet interior



The Asisto level adjustment can be easily adjusted from the inside with easy access to the adjustment screw through a guide sleeve





Company

Color concept

Changing room & wardrobe

Workshop & factory

Office & archive



# Asisto

## Hinged-door cabinets.

### Features of the hinged-door cabinets:

- + For general description, see page 374
- + Shelves made of steel in black gray RAL 7021 (standard), for additional or alternative shelves, see page 380
- + Glass doors (addtl. charge) without lock



Order no. 141032-000 & 141032-710 (steel doors)

### Dimensions and door material

#### Hinged-door cabinets

Incl. 25 mm-thick MCPB tops  
for cabinet heights up to 1,635 mm



	Width	800	1000	1200	800	1000	1200
	Depth	435	435	435	435	435	435
	Height	915	915	915	1310	1310	1310
	Interior dimensions, H x W x D	745 x 795 x 352	745 x 995 x 352	745 x 1195 x 352	1140 x 795 x 352	1140 x 995 x 352	1140 x 1195 x 352
	Shelves	1	1	1	2	2	2
	Binder heights	2	2	2	3	3	3
	Order no.	141053-000	141052-000	141051-000	141033-000	141032-000	141031-000
	Price						

	Optional:						
	& order no.	+ 141053-710	+ 141052-710	+ 141051-710	+ 141033-710	+ 141032-710	+ 141031-710
	& addtl. charge						

	Optional:						
	& order no.	+ 141053-750	+ 141052-750	+ 141051-750	+ 141033-750	+ 141032-750	+ 141031-750
	& addtl. charge						

MCPB = Melamine coated particle board

**+ Alternative top covers**

Solid-core/HPL or steel → p. 380

**+ Additional shelves**

Selection → p. 380

**+ Accessories**

Binder supports and hanging frames → p. 381

**→ Body and door color**

Color concept → p. 48

**→ Door decor (possibly top decor) or door color (with steel doors)**

Color concept → p. 50

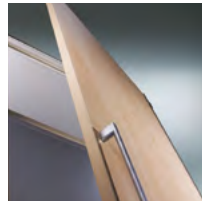

MCPB wood decor doors are standard for all Asisto cabinets (19 mm thick)



Steel doors are optional and feature double-wall insulation (19 mm thick)



Glass doors are optional and consist of safety glass (TSG) with a thickness of 6 mm

Order no. 141002-000 & 141002-710 (steel doors)

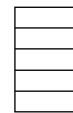
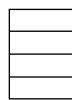
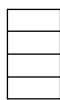
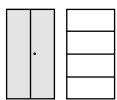

800	1000	1200	800	1000	1200
435	435	435	435	435	435
1635	1635	1635	1980	1980	1980
1465 x 795 x 352	1465 x 995 x 352	1465 x 1195 x 352	1825 x 795 x 352	1825 x 995 x 352	1825 x 1195 x 352
3	3	3	4	4	4
4	4	4	5	5	5
141013-000	141012-000	141011-000	141003-000	141002-000	141001-000

+ 141013-710	+ 141012-710	+ 141011-710	+ 141003-710	+ 141002-710	+ 141001-710
--------------	--------------	--------------	--------------	--------------	--------------

+ 141013-750	+ 141012-750	+ 141011-750	+ 141003-750	+ 141002-750	+ 141001-750
--------------	--------------	--------------	--------------	--------------	--------------

**+** Sound absorption in the side walls  
For all cabinet and shelving widths for more pleasant sound behavior of the cabinet

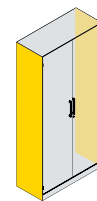
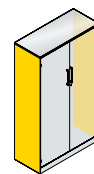
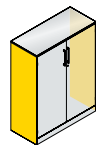
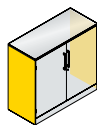

 Sandwich construction (steel-absorption layer-steel)	For cabinet height	915	1310	1635	1980
	Binder heights	2	3	4	5
	Per cabinet/shelf & order no.	+ 141050-701	+ 141030-701	+ 141010-701	+ 141000-701
	& addtl. charge				

# Asisto

## Office bookcases.

### Features of the office bookcases:

- + For general description, see p. 374
- + Shelves made of steel as standard in black gray, for additional/alternative shelves, see p. 380



Order no. 140031-000

### Dimensions and version

Incl. MCPB tops, 25 mm thick, for shelving up to 1,635 mm in height



Depth: 435	Height	915	915	1310	1310	1310
	Width	800	1000	800	1000	1200
	Shelves	1	1	2	2	2
	Binder heights	2	2	3	3	3
	Interior dimensions, HxWxD	745 x 795 x 352	745 x 995 x 352	1140 x 795 x 352	1140 x 995 x 352	1140 x 1195 x 352
	Order no.	140053-000	140052-000	140033-000	140032-000	140031-000
	Price					

→ Body color

Color concept → p. 48

→ Top decor

Color concept → p. 52





Company

Color concept

Changing room & wardrobe

Workshop & factory

Office & archive

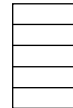
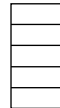
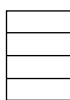

1635	1635	1635	1980	1980	1980
800	1000	1200	800	1000	1200
3	3	3	4	4	4
4	4	4	5	5	5
1465 x 795 x 352	1465 x 995 x 352	1465 x 1195 x 352	1825 x 795 x 352	1825 x 995 x 352	1825 x 1195 x 352
140013-000	140012-000	140011-000	140003-000	140002-000	140001-000

MCPB = Melamine coated particle board

**+ Accessories**

Tops → p. 380

**+ Additional shelves**

Selection → p. 380

**+ Sound absorption**

Selection → p. 377



# Asisto

## Accessories for hinged-door cabinets and office bookcases.



Steel shelves, black gray,  
load capacity: 70 kg  
Order no. ...-80



Glass shelves  
made of 6 mm-thick safety glass (TSG),  
load capacity: 40 kg  
Order no. ...-580

### Additional shelves

Coated steel, black gray

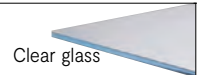

 <p>Steel</p>	For cabinet width	800	1000	1200
	Width x depth	794 x 352	994 x 352	1194 x 352
	Order no.	140003-80	140002-80	140001-80
	Unit price			

### Alternative design

 <p>Clear glass</p>	Thickness	6	6	6
	Order no.	140003-580	140002-580	140001-580
	Unit price			

### Alternative top covers

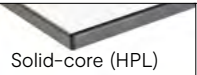
As solid-core/HPL or steel top,  
instead of MCPB top

 <p>Solid-core (HPL)</p>	For cabinet width	800	1000	1200
	Depth	435	435	435
	Thickness	13	13	13
	Order no.	140003-130	140002-130	140001-130
	& addtl. charge			
 <p>Steel</p>	Thickness	7	7	7
	Order no.	140003-110	140002-110	140001-110
	& addtl. charge			

+ Top design

Selection → p. 52



## Binder support

Attachable, for steel shelves, black gray

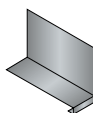

Height	200
Width	100
Depth	270
Order no.	140000-701
Price	



## Shelf with coat rack rail

Extendable, below the shelf, without coat hangers

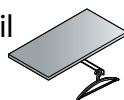

For cabinet width	800
Dimensions, HxWxD	24 x 759 x 352
Interior dimensions, WxD	759 x 363
Order no.	140003-88
Price	

## Hanging frame

Fully extendable, on ball bearings, with 2/4 adjustable vertical fixed links, incl. double anti-tilt mechanism, for DIN A4 files. **Cannot be retrofitted**

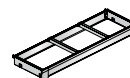
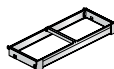

For cabinet width	800	1000	1200
Inner useful depth	330	330	330
Rows	2-row	2-row	3-row
Order no.	140003-811	140002-811	140001-811
Price			

# Certos

## Flame-resistant cabinets.

### Features of the flame-resistant Certos hinged-door cabinets:

- + **Double-walled on all sides** and especially sturdy steel construction with high-quality enamel coating
- + 25 mm-thick special insulating plates between the walls, category A1, non-flammable according to DIN 4102
- + Protection against minor fires and attempted burglary
- + Increased burglary protection thanks to burglar-proof door design on the side and sturdy door locks which snap into the side walls on the left and right
- + Wide range of different dimensions for any application
- + With sliders for floor protection as standard
- + Shelves, coated light gray
- + 5-bolt lock system (3 on the sides, 1 each at the top/bottom)
- + Double-bit safety lock with 2 keys
- + Optional electronic code lock
- + Doors on external sturdy bolt hinges, convenient door opening angle of approx. 180°
- + Highly flexible interior fitting options thanks to adjustability in 15 mm steps
- + High load capacity of 70 kg per shelf



Order no. 1161-000

### Dimensions and version

Flame-resistant, incl. 25 mm-thick MCPB tops for cabinet heights up to 1,226 mm

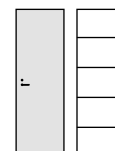
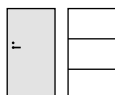

Depth: 500	Height	1226	1226	1226	1950
	Width	650	930	1200	650
	Interior dimensions, HxWxD	1060 x 598 x 429	1060 x 878 x 429	1060 x 1148 x 429	1810 x 598 x 429
	Shelves	2	2	2	4
	Weight	Approx. 64 kg	Approx. 84 kg	Approx. 102 kg	Approx. 92 kg
	Binder heights	3	3	3	5
	Security compartment dimensions, HxWxD	-	-	-	-
	Order no.	1160-000	1171-00	1181-00	1161-000
	Price				

### + Additional shelves Coated steel

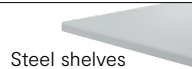
	Width x depth	597 x 428	877 x 428	1147 x 428	597 x 428
	Order no.	+ 1160-80	+ 1170-80	+ 1180-80	+ 1160-80
	Unit price				

### → Body and door color

Color concept → p. 48

### → Top decor

Color concept → p. 52





Order no. 1170-100



5-bolt  
lock  
system

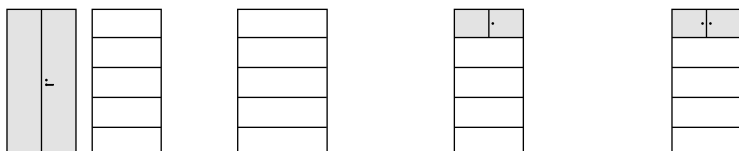

1950	1950	1950	1950
930	1200	930	930
1810 x 878 x 429	1810 x 1148 x 429	1810 x 878 x 429	1810 x 878 x 429
4	4	3	3
Approx. 115 kg	Approx. 140 kg	Approx. 120 kg	Approx. 123 kg
5	5	4	4
-	-	1 (two-door) 335 x 758 x 400	2 (single-door) 335 x 370 x 400
1170-00	1180-00	1170-100	1170-200



Order no. 1160-000

877 x 428	1147 x 428	877 x 428	877 x 428
+ 1170-80	+ 1180-80	+ 1170-80	+ 1170-80

**+ Accessories**

Hanging frames and locks → p. 384



# Accessories for flame-resistant cabinets

## Suspension bars

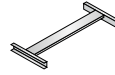
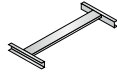

System	Elba/Leitz		Zippel	
For cabinet width	930	1200	930	1200
Inner useful width	825	1095	825	1095
Order no.	1170-82	1180-82	1170-83	1180-83
Price				

## Hanging frame

**Fully extendable, on ball bearings,**  
black gray color, with 2 adjustable  
dividers, **includes anti-tilt mechanism,**  
**cannot be retrofitted**

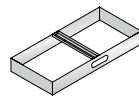

For cabinet width	930	1200
For cabinet depth	500	500
Inner useful depth	328	328
Rows	2-row	2-row and 1 extra compartment
For files	DIN A4	DIN A4
Order no.	1170-8110	1180-8110
Price		



## Additional accessories



Version	Electronic lock	Single or spare key	Handle silver anodized
	In black (instead of double-bit lock)		
Order no.	1131-02	1128-3399	1170-701
& addtl. charge			





Company

Color concept

Changing room & wardrobe

Workshop & factory

Office & archive



# Sliding-door cabinets

## Space-saving and tidy.



## Acurado series

### **The attractively priced and spacing-saving sliding-door cabinets**

- + Sturdy steel construction with high-quality enamel coating
- + With sliders for floor protection as standard
- + Shelves, coated light gray
- + Push and turn cylinder lock with 2 keys and optional exchangeable cylinder
- + Easy to move sliding doors with long-lasting special casters
- + Complete product line (different dimension variants and interior fittings for every requirement)



To the products →



## Asisto series

### The attractive and flexible space savers

- + Sturdy steel construction with high-quality enamel coating
- + Appealing design thanks to narrow edges
- + Sliders for floor protection, as standard with level adjustment, adjustable from inside
- + Metal cabinet handles, matt nickel-plated
- + Shelves, coated black gray
- + Safety lock (push and turn cylinder lock) with exchangeable cylinder, 2 keys
- + Easy to move sliding doors with long-lasting special casters
- + Doors with wood decor fronts as standard, also available in steel (exchangeable door front concept)
- + Complete product line (different dimension variants and interior fittings for every requirement)



Hinged-door cabinets → p. 356

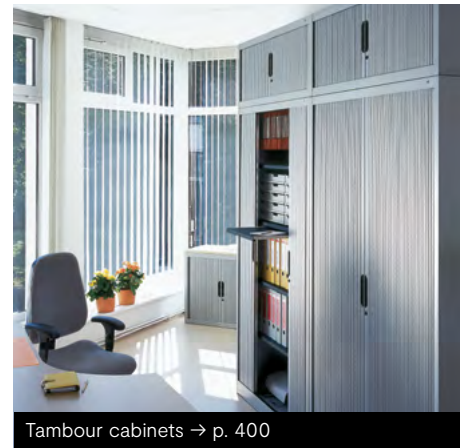

Tambour cabinets → p. 400

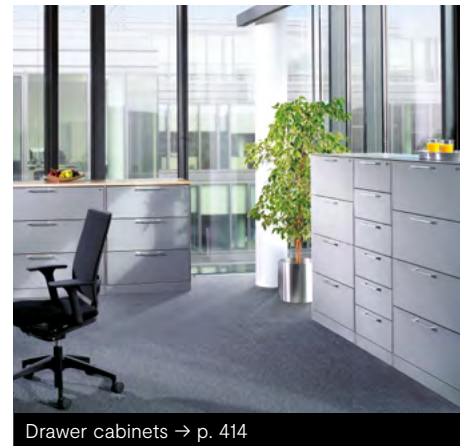

Drawer cabinets → p. 414



# Acurado

## Sliding-door cabinets with steel doors.

### Features of the Acurado sliding-door cabinets:

- + Sturdy steel construction with high-quality enamel coating
- + Wide range of different dimensions for any application
- + With sliders for floor protection as standard
- + Shelves, coated light gray
- + Push and turn cylinder lock with 2 keys and optional exchangeable cylinder
- + Easy to move sliding doors with long-lasting special casters
- + Highly flexible interior fitting options thanks to adjustability in 15 mm steps
- + Interesting range of counter and top solutions
- + High load capacity of 70 kg per shelf, reinforced shelf can bear loads up to 110 kg, for reinforcement see page 394



Order no. 2140-00

Sample visualization of the functional floor space required by space-saving cabinet types (The example does not take into account the possibility of overlapping traffic areas according to regulations.)

- = Functional area
- = User area
- = Traffic area

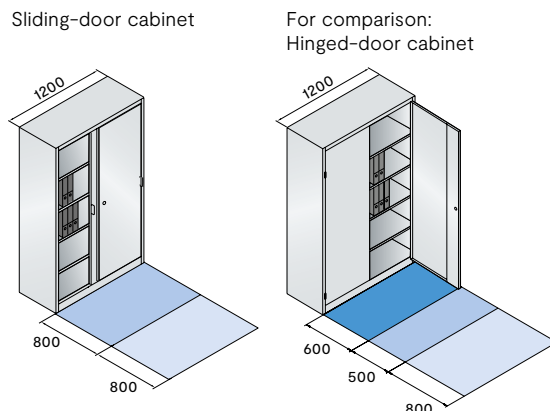

### Dimensions and version

Adjustable shelves

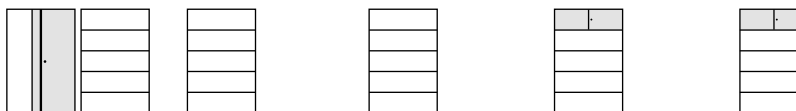

Height: 1,950	Width	1200	1200	1200	1200	1200
	Depth	400	500	600	400	500
	Interior dimensions, H x W x D	1840 x 1197 x 328	1840 x 1197 x 428	1840 x 1197 x 528	1840 x 1197 x 328	1840 x 1197 x 428
	Shelves	4	4	4	3	3
	Center partition	-	-	-	-	-
	Suspension bars	-	-	-	-	-
	Security compartments single-door (per side)	-	-	-	2 400 x 595 x 290	2 400 x 595 x 390
	Order no.	2040-00	2050-00	2060-00	2040-200	2050-200
	Price					

→ Body and door color

Color concept → p. 48



Order no. for top cabinet above: 2045-00/2145-00  
 Order no. for basic cabinets below: 2040-00/2140-00



Order no. for top cabinet above: 2044-00/2144-00  
 Order no. for basic cabinets below: 2040-00/2140-00

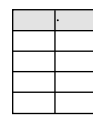
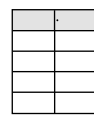
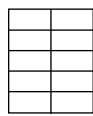
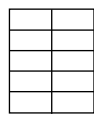
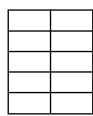
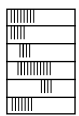

1200	1600	1600	1600	1600	1600	1600
500	400	500	600	400	500	500
1840 x 1197 x 428	1840 x 1596 x 328	1840 x 1596 x 428	1840 x 1596 x 528	1840 x 1596 x 328	1840 x 1596 x 428	1840 x 1596 x 428
-	2 x 4	2 x 4	2 x 4	2 x 3	2 x 3	-
-	1	1	1	1	1	1
6 (Elba/Leitz)	-	-	-	-	-	2 x 6 (Elba/Leitz)
-	-	-	-	2 400 x 795 x 290	2 400 x 795 x 390	-
2050-60	2140-00	2150-00	2160-00	2140-100	2150-100	2150-60

+ Accessories

Additional shelves and underframes → p. 394

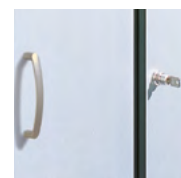

**Ergonomic bow-shaped handles:**  
 Made of metal for easy operation.

# Acurado

## Top cabinets with steel sliding doors.



Order no. 2044-00 (top cabinet)

### Dimensions and version

Incl. accessories for mounting to underbench cabinet, requires tops for use as occasional cabinets



Height	500	500	790	790	1000	1000
Width	1200	1200	1200	1200	1200	1200
Depth	400	500	400	500	400	500
Interior dimensions, HxWxD	450 x 1197 x 328	450 x 1197 x 428	740 x 1197 x 328	740 x 1197 x 428	950 x 1197 x 328	950 x 1197 x 428
Shelves	-	-	1	1	2	2
Binder heights	1	1	2	2	2 + Restfach	2 + Restfach
Order no.	2044-00	2054-00	2045-00	2055-00	2046-00	2056-00
Price						

→ Customer must provide wall mounting for top cabinets

**Top covers** made of MCPB, 25 mm thick, for use as occasional cabinet

<p>MCPB</p>	For cabinet width	1200	1200	1200	1200	1200	1200
	Depth	400	500	400	500	400	500
	& order no.	+ 2016-000	+ 2017-000	+ 2016-000	+ 2017-000	+ 2016-000	+ 2017-000
	& unit price						

→ **Body and door color**

Color concept → p. 48

→ **Top decor**

Color concept → p. 52





# Acurado

## Occasional cabinets with steel sliding doors.



Order no. 2147-1200



Order no. 2048-1200

### Dimensions and version

Incl. 25 mm-thick MCPB tops

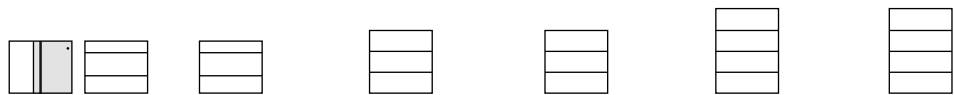

Width: 1,200	Height	1000	1000	1200	1200	1600	1600
	Depth	400	500	400	500	400	500
	Shelves	2	2	2	2	3	3
	Binder heights	2 1/2	2 1/2	3	3	4	4
	Interior dimensions, HxWxD	855 x 1197 x 328	855 x 1197 x 428	1055 x 1197 x 328	1055 x 1197 x 428	1455 x 1197 x 328	1455 x 1197 x 428
	Order no.	2046-1200	2056-1200	2047-1200	2057-1200	2048-1200	2058-1200
	Price						

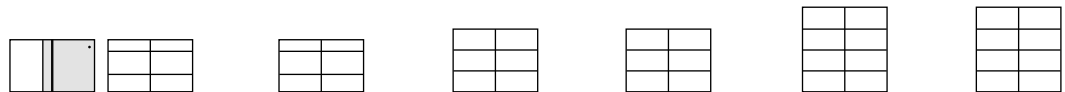

Width: 1,600	Height	1000	1000	1200	1200	1600	1600
	Depth	400	500	400	500	400	500
	Shelves	2x2	2x2	2x2	2x2	2x3	2x3
	Center partition	1	1	1	1	1	1
	Binder heights	2 1/2	2 1/2	3	3	4	4
	Interior dimensions, HxWxD	855 x 1596 x 328	855 x 1596 x 428	1055 x 1596 x 328	1055 x 1596 x 428	1455 x 1596 x 328	1455 x 1596 x 428
	Order no.	2146-1200	2156-1200	2147-1200	2157-1200	2148-1200	2158-1200
	Price						

→ Body and door color

Color concept → p. 48

→ Top decor

Color concept → p. 52





## Dimensions and version

**Desk height**, adjustable level,  
adjustable shelves,  
1,200 and 1,600 mm in width,  
with center partition,  
with 25 mm-thick MCPB top



Height: 720 Depth: 400	Width	800	1000	1200	1600
	Shelves	1	1	2 (1 per side)	2 (1 per side)
	Binder heights	2	2	2	2
	Interior dimensions, H x W x D	675 x 740 x 340	675 x 940 x 340	675 x 564 x 340	675 x 764 x 340
	Order no.	5722-00	5725-00	5723-00	5724-00
	Price				

### + Additional SLIM shelves

	For cabinet width	800	1000	1200	1600
	Width x depth	740 x 340	940 x 340	563 x 340	740 x 340
	Center partition	-	-	1	1
	& order no.	+ 5722-80	+ 5725-80	+ 5723-80	+ 5724-80
	& unit price				

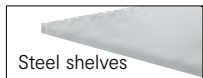

### + Underframes made of square tube, 150 mm high, adjustable level, black gray RAL 7021, other colors on request

	For cabinet width	800	1000	1200	1600
	& order no.	+ 2026-00	+ 2031-00	+ 2027-00	+ 2029-00
	& unit price				



### + Accessories

Additional shelves → p. 394

MCPB = Melamine coated particle board

# Acurado

## Accessories for sliding-door cabinets.

### Additional shelves

Coated steel, light gray

	For cabinet dimensions	1200 x 400	1200 x 500	1600 x 400	1600 x 500
	Width x depth	1196 x 327	1196 x 427	796 x 327	796 x 427
	Center partition	-	-	1	1
	Order no.	2040-80	2050-80	2140-80	2150-80
	Unit price				

### Binder supports

**Attachable**, with 2-fold edging, suitable for all shelves

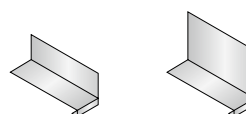

### Reinforced shelf

		Height	100	200
Load capacity per shelf	110 kg	Depth/Width x Depth	100 x 230	100 x 270
Order no.	...-802	Order no.	4221-25	4222-25
Price	Double the shelf price	Price		

### Suspension bars

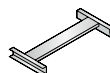
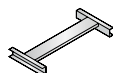

System	Elba/Leitz		Zippel	
For cabinet width	1200	1600	1200	1600
For cabinet depth	500	500	500	500
Inner useful width	1111	731	1111	731
Order no.	2050-82	2150-82	2050-83	2150-83
Price				



Suspension bars for Elba/Leitz system, (order no. 2050-82, 2150-82)

## Underframes

150 mm high, square tube, adjustable level. Black gray RAL 7021, other colors on request

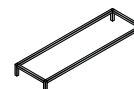
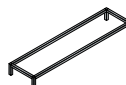
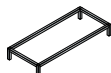
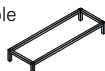

For cabinet width	1200	1200	1600	1600
For cabinet depth	400	500	400	500
Order no.	2027-00	2028-00	2029-00	2030-00
Price				

## Shelf with coat rack rail

Below the shelf, possible from 500 mm exterior cabinet depth only, without coat hangers



Includes holder	
Order no.	...-88
Price	On request

## Shelf support set

Zinc-plated, pack. unit: 20 pc.

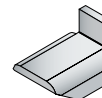

Order no.	1118-00-20
Price	

## Keys and locks

	Simultaneously locking	Exchangeable cylinder for master key system	Master key for exchangeable cylinder	Removal key for exchangeable cylinder	Single/spare key for Acurado series	Lock with lock no. upon request (longer delivery times)
Order no.	2025-021	2025-03	2025-031	2025-026	0005-10	...-...99
Price						On request



# Asisto

## Sliding-door cabinets.

### Features of the sliding-door cabinets:

- + Sturdy steel construction with high-quality enamel coating
- + Appealing design thanks to narrow edges which you can only achieve with intelligently manufactured steel bodies
- + Excellent stability and suitability for moving thanks to the Asisto steel body (with useful magnetic surfaces on the side)
- + Sliders for floor protection, as standard with level adjustment, adjustable from inside
- + Metal cabinet handles, matt nickel-plated
- + Shelves, coated black gray
- + Safety lock (push and turn cylinder lock) with exchangeable cylinder, 2 keys
- + Easy to move sliding doors with long-lasting special casters
- + Different fronts (steel, wood) and tops can be matched to the steel body
- + Highly flexible interior fitting options thanks to adjustability in 15 mm steps
- + High load capacity of 70 kg per shelf
- + MCPB tops, 25 mm thick, for cabinets up to 1,635 mm in height



Order no. 142002-000  
& 142002-710 (steel doors)



### Dimensions and door material

Incl. 25 mm-thick MCPB tops for cabinet heights up to 1,635 mm, **without** center partition, adjustable shelves

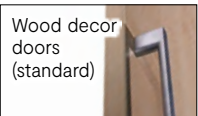

Depth: 435	Height	915	915	1310	1310
	Width	1000	1200	1000	1200
	Interior dimensions, HxWxD	745 x 995 x 352	745 x 1195 x 352	1140 x 995 x 352	1140 x 1195 x 352
	Shelves	1	1	2	2
	Binder heights	2	2	3	3
	Order no.	142052-000	142051-000	142032-000	142031-000
	Price				

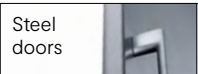
	Optional:				
	& order no.	+ 142052-710	+ 142051-710	+ 142032-710	+ 142031-710
	& addtl. charge				

→ Body and door color

Color concept → p. 48

→ Door decor (possibly top decor) or door color (with steel doors)

Color concept → p. 50



Company

Color concept

Changing room & wardrobe

Workshop & factory

Office & archive

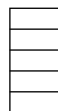

1635
1000
1465x995x352
3
4
142012-000

1635
1200
1465x1195x352
3
4
142011-000

1980
1000
1825x995x352
4
5
142002-000

1980
1200
1825x1195x352
4
5
142001-000

+ 142012-710

+ 142011-710

+ 142002-710

+ 142001-710

**+ Alternative top covers**

Solid-core/HPL or steel → p. 398

**+ Sound absorption**

Sandwich construction in the side walls → p. 398

**+ Accessories**

Shelves and binder support → p. 398

# Asisto

## Accessories for sliding-door cabinets.

### Additional shelves

Coated steel, black gray (standard),  
load capacity: 70 kg

 <p>Steel</p>	For cabinet width	1000	1200
	Width x depth	994 x 352	1194 x 352
	Order no.	140002-80	140001-80
	Unit price		



### Binder support

**Attachable,**  
for steel shelves,  
black gray

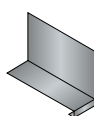

Order no.	140000-701
Price	

### Sound absorption

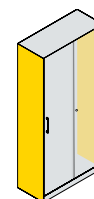
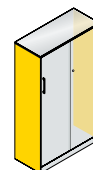
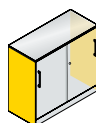

**In the side walls,** for all cabinet widths,  
for a more pleasant sound behavior of the  
cabinet



 <p><b>Sandwich construction</b> (steel-absorption layer-steel)</p>	For cabinet height	915	1310	1635	1980
	Binder heights	2	3	4	5
	Order no.	141050-701	141030-701	141010-701	141000-701
	& addtl. charge				

### Alternative top covers

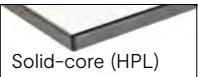
**As solid-core/HPL or steel top,**  
instead of MCPB top

 <p>Solid-core (HPL)</p>	For cabinet width	1000	1200
	Depth	435	435
	Thickness	13	13
	Order no.	140002-130	140001-130
	& addtl. charge		
 <p>Steel</p>	Thickness	7	7
	Order no.	140002-110	140001-110
	& addtl. charge		

→ **Body color**

Color concept → p. 48

HPL = High-pressure laminate  
MCPB = Melamine coated particle board





Company

Color concept

Changing room & wardrobe

Workshop & factory

Office & archive



# Tambour cabinets

More room in less space.



## Omnispace series

### **The affordable complete tambour cabinet range**

- + Body in sturdy steel construction with high-quality enamel coating
- + Sliders for floor protection, as standard with level adjustment, adjustable from inside
- + Shelves, coated black gray
- + Hook bolt lock with 2 keys
- + Plastic tambour doors made of polypropylene with recessed grip, smooth and quiet functioning
- + Complete product line (different dimension variants and interior fittings for every requirement)





## Asisto series

**The elegant single-door cabinets:  
Flexible and especially easy to move**

- + Body in sturdy steel construction with high-quality enamel coating
- + Appealing design thanks to narrow edges
- + Sliders for floor protection, as standard with level adjustment, adjustable from inside
- + Shelves, coated black gray
- + Hook bolt lock with exchangeable cylinders, 2 keys
- + Plastic tambour doors, hinged on the left, with matt nickel-plated bow-shaped handle, especially smooth and quiet functioning
- + Doors also available with sound-absorbing acoustic tambour
- + Complete product line (different dimension variants and interior fittings for every requirement)



Hinged-door cabinets → p. 356



Sliding-door cabinets → p. 386

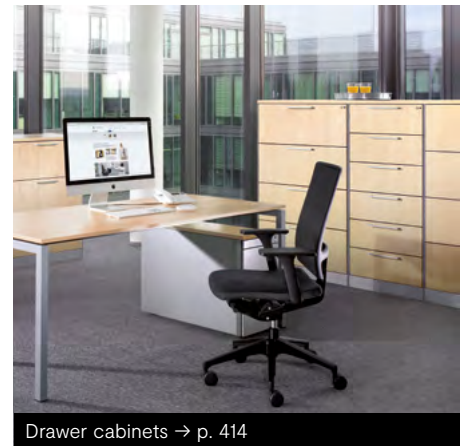

Drawer cabinets → p. 414

# Omnispace series

## Tambour cabinets.

### The Omnispace series offers:

- + Body in sturdy steel construction with high-quality enamel coating
- + Planning dimensions: 600, 800, 1,000 and 1,200 mm
- + Sliders for floor protection, as standard with level adjustment, adjustable from inside
- + No assembly required—tambour cabinets are delivered fully assembled
- + Shelves, coated black gray
- + Body and internal walls have the same color
- + Hook bolt lock with 2 keys
- + Tambour doors consist of full-length, flexible plastic mats (polypropylene) with a practical recessed grip for easy operation
- + Tambours move smoothly and quietly
- + Highly flexible interior fitting options thanks to adjustability in 15 mm steps
- + Load capacity of 50 kg per shelf



Order no. 3200-088L



Order no. 3203-00



### Dimensions and version

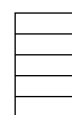
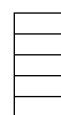
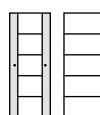
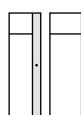
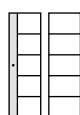
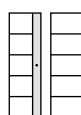

Height: 1980 Depth: 420	Width	600	600	600	800	1000	1200
	Interior dimensions, HxWxD	1836 x 493 x 385	1836 x 493 x 385	1836 x 493 x 385	1836 x 651 x 385	1836 x 851 x 385	1836 x 1051 x 385
	Shelves	4	4	1	4	4	4
	Binder heights	5	5	-	5	5	5
	Description	Tambour door stopping on left	Tambour door stopping on right	Stopping on left with extendable coat rack rail	-	-	-
	Order no.	3200-00L	3200-00R	3200-088L	3201-00	3202-00	3203-00
	Price						



+ Top cabinets

Selection → p. 406

→ Body color

Color concept → p. 48

→ Tambour fronts

Color concept → p. 406

+ Accessories

Extendable coat rack rail → p. 407





Company

Color concept

Changing room & wardrobe

Workshop & factory

Office & archive

Tambour cabinet

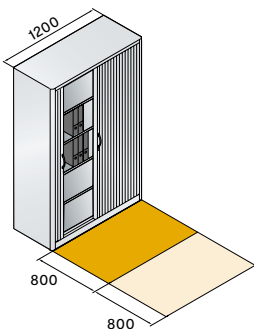

For comparison: Hinged-door cabinet

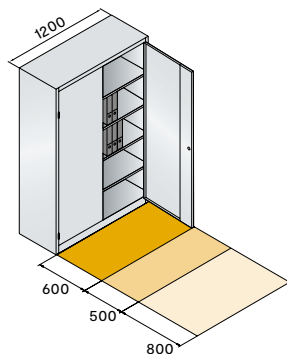

- = Functional area
- = User area
- = Traffic area

Sample visualization of the functional floor space required by space-saving cabinet types (The example does not take into account the possibility of overlapping traffic areas according to regulations)



# Omnispace series

## Tambour cabinets.

### Dimensions and version

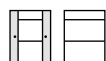

Depth: 420

Height
Width
Interior dimensions, HxWxD
Shelves
Binder heights
Order no.
Price

1030
800
886 x 651 x 385
2
2 + extra compartment
3241-00

1030
1000
886 x 851 x 385
2
2 + extra compartment
3242-00

1030
1200
886 x 1051 x 385
2
2 + extra compartment
3243-00



Depth: 420

Height
Width
Interior dimensions, HxWxD
Shelves
Binder heights
Order no.
Price

1345
800
1201 x 651 x 385
3
3 + extra compartment
3221-00

1345
1000
1201 x 851 x 385
3
3 + extra compartment
3222-00

1345
1200
1201 x 1051 x 385
3
3 + extra compartment
3223-00



**+** **Top covers**  
25 mm thick, in MCPB,  
please specify top decor



MCPB = Melamine coated particle board

For cabinet width
Depth
& order no.
& addtl. charge

800
420
+ 3212-0800

1000
420
+ 3212-1000

1200
420
+ 3212-1200



**Standard level adjustment:**  
For Omnispace tambour cabinets,  
height adjustable up to 10 mm  
+ Easy to access  
+ Easy to adjust

→ **Body color**

Color concept → p. 48

→ **Top decor**

Color concept → p. 52

→ **Tambour fronts**

Color concept → p. 406

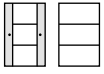

1230

800

1086 x 651 x 385

2

3

3231-00



1230

1000

1086 x 851 x 385

2

3

3232-00



1230

1200

1086 x 1051 x 385

2

3

3233-00



Order no. 3213-00

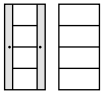

1660

800

1516 x 651 x 385

3

4

3211-00



1660

1000

1516 x 851 x 385

3

4

3212-00



1660

1200

1516 x 1051 x 385

3

4

3213-00



Order no. 3243-00  
& 57700-701



Order no. 3233-00  
& 3212-1200 (top cover)



**+ Accessories**







Suspension bars → p. 407

# Omnispace series

## Top and occasional cabinets.

### Dimensions and version



#### Top cabinets

					
Height: 450 Depth: 420	Width 600	600	800	1000	1200
	Interior dimensions, HxWxD 356 x 493 x 385	356 x 493 x 385	356 x 651 x 385	356 x 851 x 385	356 x 1051 x 385
	Description	Tambour door stopping on left	Tambour door stopping on right	-	-
	Order no.	3260-00L	3260-00R	3261-00	3262-00
	Price				

**+** Wall mount  
Customer must provide wall mount for top cabinets

#### Occasional cabinets

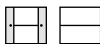
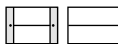
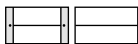
Desk height  
incl. 25 mm-thick MCPB top

			
Height: 720 Depth: 420	Width 800	1000	1200
	Interior dimensions, HxWxD 596 x 651 x 385	596 x 851 x 385	596 x 1051 x 385
	Shelves	1	1
	Binder heights	1 + extra compartment	1 + extra compartment
	Order no.	3251-00	3252-00
	Price		



### Available colors and materials

Available **body colors** (please note: additional charge for body in white aluminum, see C + P color concept on Page 48/49)

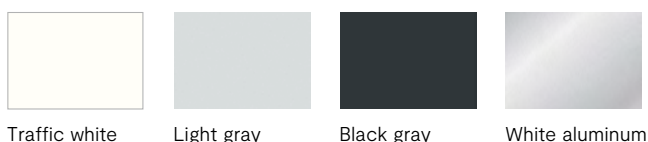

The smooth-running **plastic tambour mats** are made of polypropylene and are available for all cabinet heights in the following colors at no additional charge:

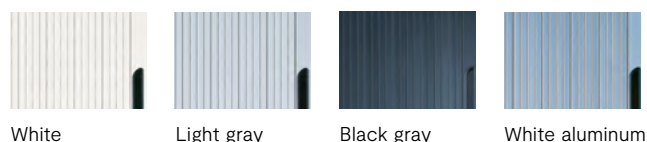

#### Top covers

25 mm thick with 3 mm edge band available in 3 decors:



MCPB = Melamine coated particle board  
Master key system—price on request

# Omnispace series

## Accessories for tambour cabinets.

### Set of casters (4 pc.)

For 720 and 1,030 mm-high cabinets only.  
4 casters, both front casters with lock.

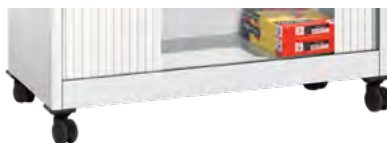

Order no. 57700-701

Price

### Additional shelves

Coated steel, black gray (standard)

 Steel shelves	For cabinet width	600	800	1000	1200
	Width x depth	493 x 360	651 x 360	851 x 360	1051 x 360
	Order no.	3200-80	3201-80	3202-80	3203-80
	Price				

### Suspension bars

(Suspension bars from other systems on request)

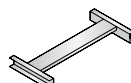
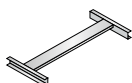

	Elba/Leitz				Zippel			
For cabinet width	600	800	1000	1200	600	800	1000	1200
Order no.	3200-82	3201-82	3202-82	3203-82	3200-83	3201-83	3202-83	3203-83
Price								



### Hanging frame

Fully extendable,  
max. 4 hanging frames per cabinet possible, color black gray RAL 7021

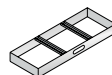

	For DIN A4 suspension files (incl. anti-tilt mechanism, cannot be retrofitted!)		
For locker width	800	1000	1200
Rows	1-row	2-row	3-row
Order no.	3201-811	3202-811	3203-811
Price			



### Shelf with coat rack rail

Extendable, below the shelf, without coat hangers



For cabinet width	600	800
Order no.	3200-88	3201-88
Price		



### Binder support

Attachable, suitable for all shelves



### Single/ spare key



### Lock

Simultaneous locking



Order no. 3200-701

Price

Order no. 3200-7027

Price\*

Order no. 3200-7021

Price\*

\*When ordering for cabinet



# Asisto

## Tambour cabinets

### Features of Asisto tambour cabinets:

- + Body in sturdy steel construction with high-quality enamel coating
- + Appealing design thanks to narrow edges which you can only achieve with intelligently manufactured steel bodies
- + Excellent stability and suitability for moving thanks to the Asisto steel body (with useful magnetic surfaces on the side)
- + Sliders for floor protection, as standard with level adjustment, adjustable from inside
- + No assembly required—tambour cabinets are delivered fully assembled
- + Shelves, coated black gray
- + Hook bolt lock with exchangeable cylinders, 2 keys
- + Tambour doors consist of full-length, flexible plastic mats (polypropylene) with aluminum locking bar and metal cabinet handle, matt nickel-plated, for easy operation
- + Tambours move especially smoothly and quietly
- + Doors also available with sound-absorbing acoustic tambour
- + Highly flexible interior fitting options thanks to adjustability in 15 mm steps
- + Load capacity of 50 kg per shelf
- + MCPB tops, 25 mm thick, for cabinets up to 1,635 mm in height



**Patented acoustic tambour:**  
Absorb sound, improve acoustics—and look good doing it: The light-running, patented and award-winning special tambour absorbs a majority of the sound occurring in day-to-day work. In some frequency ranges, it “swallows” almost seven times as much sound as a conventional cabinet.



+ **Optional for all cabinets:**  
**Make the office an area of tranquility!**  
“Typical” background noise is part and parcel of the day-to-day routine in open-concept offices: Talking, clatter and ringing hamper concentration while working. All the better if you can solve this problem by utilizing the office storage you need anyway and create a healthy, pleasant working atmosphere for employees at the same time.

### Tambour cabinets for efficient office space utilization

When open, tambour cabinets always provide unobstructed access without the hindrance of doors extending into the room. This allows you to

- + fit more workstations and storage space in the room
- + or achieve a more generous appearance of your furnishings while using the same amount of space,
- + utilizing valuable office space more efficiently!

Tambour cabinet

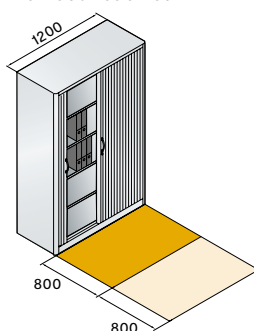

For comparison: Hinged-door cabinet

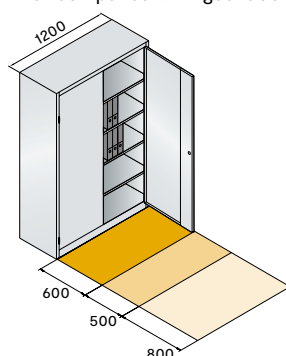

- = Functional area
- = User area
- = Traffic area

Sample visualization of the functional floor space required by space-saving cabinet types (The example does not take into account the possibility of overlapping traffic areas according to regulations)



Also available with **acoustically effective tambour doors**

Order no. 143001-000 & 143001-716 (acoustic tambour)



Order no. 143002-000

## Dimensions and tambour material

Adjustable shelves

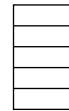
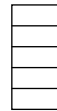
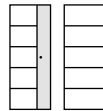

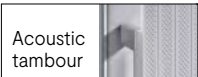
Height: 1,980 Depth: 435	Width	800	1000	1200
	Interior dimensions, H x W x D	1865 x 695 x 365	1865 x 895 x 365	1865 x 1095 x 365
 Standard tambour	Shelves	4	4	4
	Binder heights	5	5	5
	Order no.	143003-000	143002-000	143001-000
	Price			
 Acoustic tambour	Optional:			
	& order no.	-	-	+ 143001-716
	& addtl. charge	-	-	

### + Accessories

Additional shelves, hanging frames and binder support → p. 412

### → Body color

Color concept → p. 48

### → Tambour fronts

Please choose from white, light gray, black gray and white aluminum (acoustic tambour only available in white and white aluminum)

Color concept → p. 413

# Asisto

## Tambour cabinets.



Order no. 143053-000



Order no. 143012-000

### Dimensions and tambour material

Incl. MCPB tops, 25 mm thick, adjustable shelf

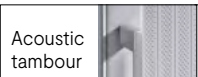

 <p>Standard tambour</p>	Height	915	915	915
	Width	800	1000	1200
	Interior dimensions, HxWxD	785x695x365	785x895x365	785x1095x365
	Shelves	1	1	1
	Binder heights	2	2	2
	Order no.	143053-000	143052-000	143051-000
	Price			
 <p>Acoustic tambour</p>	Optional:			
	& order no.	-	-	+ 143051-716
	& addtl. charge	-	-	



#### Tambour fronts

Please choose from white, light gray, black gray and white aluminum (acoustic tambour only available in white and white aluminum)

→ **Body color**

Color concept → p. 48

Color concept → p. 413



Company

Color concept

Changing room & wardrobe

Workshop & factory

Office & archive

1310	1310	1310	1635	1635	1635
800	1000	1200	800	1000	1200
1176x695x365	1176x895x365	1176x1095x365	1505x695x365	1505x895x365	1505x1095x365
2	2	2	3	3	3
3	3	3	4	4	4
143033-000	143032-000	143031-000	143013-000	143012-000	143011-000
-	-	+ 143031-716	-	-	+ 143011-716
-	-		-	-	

MCPB = Melamine coated particle board

**+ Accessories**

Alternative top covers and additional shelves → p. 412





# Asisto

## Accessories for tambour cabinets.

### Alternative top covers

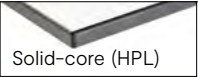
As **solid-core/HPL or steel top**, instead of MCPB top

Depth: 435	For cabinet width	800	1000	1200
 <p>Solid-core (HPL)</p>	Thickness	13	13	13
	Order no.	140003-130	140002-130	140001-130
	& addtl. charge			
 <p>Steel</p>	Thickness	7	7	7
	Order no.	140003-110	140002-110	140001-110
	& addtl. charge			

### Additional shelves

Coated steel, black gray (standard)

	For cabinet width	800	1000	1200
	Width x depth	724 x 363	924 x 363	1124 x 363
	Order no.	143003-80	143002-80	143001-80
	Price			

### Hanging frame

Fully extendable, on ball bearings, with 2/4 adjustable vertical fixed links, incl. double anti-tilt mechanism, for DIN A4 files.

**Cannot be retrofitted**

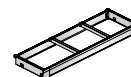
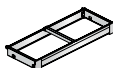

	800	1000	1200
For cabinet width	800	1000	1200
Inner useful depth	330	330	330
Rows	1-row	2-row	3-row
Order no.	143003-811	143002-811	143001-811
Price			

### Binder support

**Attachable**, for steel shelves, black gray

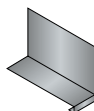

Height	200
Width	100
Depth	270
Order no.	140000-701
Price	

### Shelf with coat rack rail

**Extendable**, below the shelf, without coat hangers



For cabinet width	800
Dimensions, HxWxD	24 x 695 x 355
Interior dimensions, WxD	695 x 365
Order no.	143003-88
Price	

+ Top design

Selection → p. 52



Order no. 143001-000

## Available colors for tambour

The smooth-running plastic tambour mats are available for all cabinet heights in the following colors at no additional charge:

### Standard tambour:

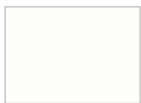

White



Light gray



Black gray



White aluminum

### Acoustic tambour:

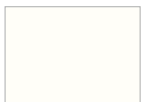

White



White aluminum

Notes on body paint according to the C+P color concept:

Body colors RAL 9016 traffic white, RAL 7035 light gray and RAL 7021 black gray are all in color group 0 and therefore have no surcharge.

The surcharge for body color RAL 9006 white aluminum (color group I) can be found in the C+P color concept on page 48/49.

# Drawer and filing cabinets

Order across the board.



## Acurado series

**The cost-effective cabinets  
for suspension files and index cards**

- + Sturdy steel construction with high-quality enamel coating
- + With sliders for floor protection as standard
- + Integrated full-width handle bar
- + Central locking system with 2 keys and exchangeable cylinder
- + Drawers are fully extendable, with anti-tilt mechanism
- + Load capacity per drawer: 50 kg
- + For DIN A4 suspension files and DIN A4/A5 index cards
- + Available in light gray RAL 7035, black gray RAL 7021, white aluminum RAL 9006 and traffic white RAL 9016

## Asisto series

**The convenience range  
for all filing tasks**

- + Sturdy steel construction with body sound absorption and high-quality enamel coating
- + Appealing design thanks to narrow edges
- + Sliders for floor protection, as standard with level adjustment, adjustable from inside
- + Elegant and ergonomic bow-shaped handles, matt nickel-plated
- + Optional wood decor fronts and tops
- + Central locking system with 2 keys and exchangeable cylinder
- + Drawers are fully extendable, with anti-tilt mechanism
- + Load capacities per drawer:
  - 50 kg (435 mm deep)
  - 60 kg (600 mm deep)
  - 100 kg (600 mm deep with heavy-duty rails)
- + Complete modular system for different filing materials



To the products →



## 7000 series

### The universal drawer cabinets for everything flat

- + Sturdy steel construction with overlay drawer fronts and high-quality enamel coating
- + With sliders for floor protection as standard
- + Elegant and ergonomic bow-shaped handles, matt nickel-plated
- + Central locking system with 2 keys
- + Drawer, fully (DIN A1) or 4/5 (DIN A0) extendable, with anti-tilt mechanism
- + Load capacity per drawer: 40 kg
- + Drawer bottoms are stepped and can be divided, therefore suitable for different applications
- + Available in two sizes (DIN A1 and DIN A0) and two cabinet heights with different drawer configurations



Hinged-door cabinets → p. 356



Sliding-door cabinets → p. 386



Tambour cabinets → p. 400



# Acurado

## Suspension file and card-index cabinets.

### Features of the Acurado suspension file and index card cabinets:

- + Sturdy steel construction with high-quality enamel coating
- + Economical solution for “classic” office tasks
- + Three heights, three widths
- + With sliders for floor protection as standard
- + Integrated full-width handle bar
- + Central locking system with 2 keys and exchangeable cylinder
- + Fully extendable steel drawers on long-lasting telescopic ball-bearing rails, flush folded in, sealed drawer bottom
- + Anti-tilt mechanism
- + Load capacity per drawer: 50 kg
- + Card-index cabinets with 2 card-index dividers per index row

### Dimensions and version

#### Suspension file cabinets

With hanging frame and sealed drawer bottom, for suspension files of size DIN A4, fully extendable



Depth: 590	Height	733	1045	1357	733	1045	1357
	Width	433	433	433	787	787	787
	Interior dimensions, HxWxD	250x330x518	250x330x518	250x330x518	250x330x518	250x330x518	250x330x518
	Drawers	2	3	4	2	3	4
	Rows	1-row	1-row	1-row	2-row	2-row	2-row
	Order no.	12412-311	12423-311	12434-311	12912-312	12923-312	12934-312
	Price						

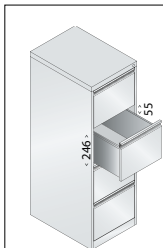

Our interior dimension specifications generally indicate **the usable dimensions** (e.g. from the suspension point of the DIN A4 size suspension file to the next lower panel or drawer bottom).

The usable dimensions from the suspension point to the **next higher** panel are indicated in the drawing above.

#### Available in the following colors with no surcharge:



Light gray  
RAL 7035



Black gray  
RAL 7021



Deep black  
RAL 9005



Traffic white  
RAL 9016

#### + Accessories

Card-index dividers and underframes → p. 418



Order no. 12434-311      Order no. 12934-312      Order no. 12923-312      Order no. 12912-312

### Dimensions and version

**Card-index cabinets** for DIN A5 and DIN A4 index cards, drawers fully extendable

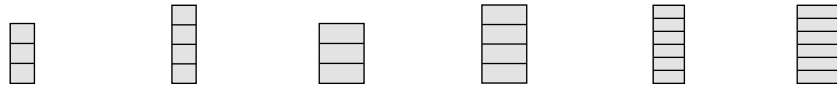

Depth: 590	Height	1045	1357	1045	1357	1357	1357
	Width	433	433	787	787	553	787
	Interior dimensions, HxWxD	285 x 300 x 518	285 x 300 x 518	285 x 300 x 518	285 x 300 x 518	185 x 214 x 518	185 x 214 x 518
	Drawers	3	4	3	4	6	6
	Rows	1-row	1-row	2-row	2-row	2-row	3-row
	For index cards	DIN A4 landscape	DIN A4 landscape	DIN A4 landscape	DIN A4 landscape	DIN A5 landscape	DIN A5 landscape
	Order no.	12423-321	12434-321	12923-322	12934-322	12736-322	12936-323
	Price						

Based on applicable standards and guidelines (e.g. EN 14073-2), **cabinets must be secured against tipping**. There are two convenient options for this:

1. Version with **wall mount\*** or
2. Version with **additional counterweight**



\*The fastening method depends on the wall material. Please use screws and dowels that are suitable for the respective type of wall (not included).

**+ Additional counterweight** if wall mounting is not possible—cannot be fitted retroactively

For cabinet width	433	553	787
Load capacity per drawer	35 kg	40 kg	50 kg
& order no.	+ 6400-01	+ 6700-01	+ 6900-01
& addtl. charge			



Order no. 12736-322      Order no. 12936-323

# Acurado

## Accessories for drawer and filing cabinets.

### Label holder

Made of plastic, per piece



**Label holder**  
Transparent, incl. white label (1 pc. per drawer as standard)

**Standard**  
For supplementation of the included inscription fields. Color black, incl. label and transparent cover

**Comfort**  
As an alternative to additional drawer labeling. Color black, incl. label and transparent cover

Version	Self-adhesive	Self-adhesive	Self-adhesive	Magnetic
H x W x D	32 x 100 x 2	26 x 76 x 4	39 x 114 x 5	39 x 114 x 5
Window, H x W	26 x 98	17 x 67	30 x 105	30 x 105
Order no.	6103-10	6103-13	6103-11	6103-12
Price				

### Underframes

150 mm high, square tube, adjustable level. Black gray RAL 7021, other colors on request



Width	433	553	787
Depth	590	590	590
Order no.	64020-00	67020-00	69020-00
Price			

### Card-index dividers

Individual

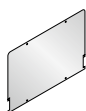

Version	For DIN <b>A4 landscape</b> index cards	For DIN <b>A5 landscape</b> index cards
Panel height	6 HU	4 HU
Order no.	6494-10	6495-10
Unit price		



All cabinets feature sealed drawer bottoms

### Exchangeable lock cylinder

With 2 keys, nickel-plated



Order no.	2025-02
Price	



### Cylinder lock with exchangeable cylinder:

As central locking system. Compatible with many other C + P furniture items. Also ideal for subsequent organization of locking groups. Flush steel drawers with integrated, full-width handle bar

### Single/spare key

Per pc.

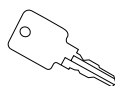

Order no.	0005-10
Price	





Company

Color concept

Changing room & wardrobe

Workshop & factory

Office & archive



# Asisto

## Drawer and filing cabinets 435 mm deep.

### Features of the Asisto 435 mm-deep drawer and filing cabinets:

- + **Cabinet depth: 435 mm, with MCPB panels and top covers as standard, can be combined with Asisto hinged-door, sliding-door and tambour cabinets**
- + Sturdy steel construction with high-quality enamel coating
- + Body with body sound absorption for pleasant sound behavior
- + Appealing design thanks to narrow edges
- + Sliders for floor protection, as standard with level adjustment, adjustable from inside
- + Elegant and ergonomic bow-shaped handles, matt nickel-plated
- + Fronts also available in steel
- + Central locking system with 2 keys and exchangeable cylinder
- + Full extension slides (width: 1,200 mm with parallel control) with self-closing system, anti-tilt mechanism and soft-close silencers as standard
- + Drawers and hanging frames in black gray or graphite black
- + Load capacity per drawer: 50 kg
- + For DIN A4 suspension files and DIN A4/A5 index cards
- + Card-index cabinets with 2 card-index dividers per index row
- + High-quality, self-adhesive plastic label holder with inscription field (1 supplied for each drawer)



Order no. 146041-313

### Dimensions and panel material of filing cabinets

With **closed** hanging frame for **DIN A4** suspension files, fully extendable, incl. 25 mm-thick MCPB top

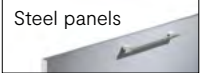

Depth: 435  	Height	1010	1310	1010	1310
	Width	800	800	1200	1200
	Interior dimensions, HxWxD	240x330x320	240x330x320	240x330x320	240x330x320
	Hanging frame	1	1	1	1
	Drawers	<b>3x6</b> HU	<b>4x6</b> HU	<b>3x6</b> HU	<b>4x6</b> HU
	Rows	2-row	2-row	3-row	3-row
	Order no.	146043-312	146023-412	146041-313	146021-413
Price					

Steel panels 	Optional:				
	& order no.	+ 6900-401	+ 6900-402	+ 6400-401	+ 6400-402
	& addtl. charge				

→ **Body color**

Color concept → p. 48

⊕ **Accessories**

Suspension plates, index row plates, label holder, exchangeable lock cylinder and single key → p. 430

→ **Panel decor (if appl., top decor) or panel color (for steel panels)**

Color concept → p. 50



## Dimensions and panel material of card-index cabinets

For **DIN A4** and **DIN A5** index cards, drawers fully extendable, incl. 25 mm-thick MCPB top

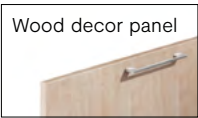

Width: 800 Depth: 435	Height	1010	1310	1310
	Interior dimensions, HxWxD	260x303x320	260x303x320	160x213x320
	Rows	2-row	2-row	3-row
	Drawers	<b>3 x 6 HU</b>	<b>4 x 6 HU</b>	<b>6 x 4 HU</b>
	For index cards	<b>DIN A4 landscape</b>	<b>DIN A4 landscape</b>	<b>DIN A5 landscape</b>
	Order no.	146043-322	146023-422	146023-623
	Price			

	Optional:			
	& order no.	+ 6900-401	+ 6900-402	+ 6900-402
	& addtl. charge			

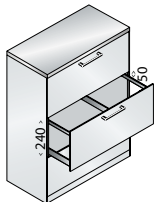

Our interior dimension specifications generally indicate **the usable dimensions** (e.g. from the suspension point of the DIN A4 size suspension file to the next lower panel or drawer bottom). The usable dimensions from the suspension point to the **next higher** panel are indicated in the drawing above.

Based on applicable standards and guidelines (e.g. EN 14073-2), cabinets must be secured against tipping. There are two convenient options for this:



- Version with **wall mount** (please use screws and dowels that are suitable for the respective type of wall)
- Version with an additional **counterweight**

**+ Additional counterweight**  
if wall mounting is not possible—cannot be fitted retroactively

For cabinet width	800	1200	800	1200
For cabinet height	1010	1010	1310	1310
Load capacity per drawer	50 kg	50 kg	50 kg	50 kg
& order no.	+ 6700-01	+ 6700-01	+ 6900-01	+ 6900-01
& addtl. charge				

MCPB = Melamine coated particle board  
1 HU = 50 mm (height unit)

# Asisto

## Drawer and filing cabinets 600 mm deep.

### Features of the drawer and filing cabinets:

- + Cabinet depth of 600 mm, as standard with panels and top covers made of steel
- + Sturdy steel construction with high-quality enamel coating
- + Body with body sound absorption for pleasant sound behavior
- + Appealing design thanks to narrow edges
- + Sliders for floor protection, as standard with level adjustment, adjustable from inside
- + Elegant and ergonomic bow-shaped handles, matt nickel-plated
- + Optional wood decor fronts and tops
- + Central locking system with 2 keys and exchangeable cylinder
- + Full extension slides on sturdy telescopic rails, with anti-tilt mechanism and self-closing system
- + Drawers and hanging frames in black gray or graphite black
- + Load capacities per drawer: 60 kg with standard rails  
100 kg with heavy-duty rails
- + Complete modular system for different filing materials
- + Card-index cabinets with 2 card-index dividers per index row
- + High-quality, self-adhesive plastic label holder with inscription field (1 supplied for each drawer)



Order no. 146243-312

### Dimensions and panel material of filing cabinets

With **closed** hanging frame

for **DIN A4** suspension files, fully extendable, incl. 7 mm-thick steel top cover

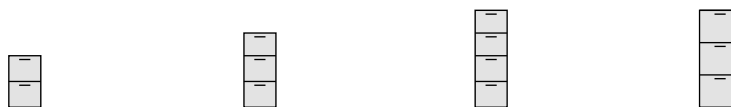

Depth: 600	Height	698	998	1298	1298
	Width	440	440	440	562
	Interior dimensions, HxWxD	240 x 330 x 518	240 x 330 x 518	240 x 330 x 518	345 x 451 x 518
	Rows	1-row	1-row	1-row	1-row
	Drawers	<b>2 x 6 HU</b>	<b>3 x 6 HU</b>	<b>4 x 6 HU</b>	<b>3 x 8 HU</b>
	For suspension files	<b>DIN A4</b>	<b>DIN A4</b>	<b>DIN A4</b>	<b>DIN A3</b>
	Order no.	146275-211	146245-311	146225-411	146224-301
	Price				

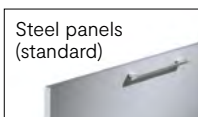

Steel panels (standard)

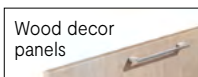

Wood decor panels

Optional:				
& order no.	+ 6400-410	+ 6400-411	+ 6400-412	+ 6700-412
& addtl. charge				

Based on applicable standards and guidelines (e.g. EN 14073-2), **cabinets must be secured against tipping**. There are two convenient options for this:

1. Version with **wall mount\*** or
2. Version with **additional counterweight**



\*The fastening method depends on the wall material. Please use screws and dowels that are suitable for the respective type of wall (not included).

→ **Body and panel color (for steel panels)**

Color concept → p. 48

→ **Panel/top decor (wood decor panels)**

Color concept → p. 50

+ **Accessories**

Soft-stop and alternative top covers → p. 430



698
800
240 x 330 x 518
2-row
<b>2 x 6 HU</b>
<b>DIN A4</b>
146273-212

998
800
240 x 330 x 518
2-row
<b>3 x 6 HU</b>
<b>DIN A4</b>
146243-312

1298
800
240 x 330 x 518
2-row
<b>4 x 6 HU</b>
<b>DIN A4</b>
146223-412

#### Cabinet heights For top covers

in steel (standard)

1298
998
698
or
<b>MCPB</b> (see Page 431)
1316
1016
716

MCPB = Melamine coated  
particle board  
1 HU = 50 mm (height unit)

+ 6900-410

+ 6900-411

+ 6900-412

#### + Additional counterweight

if wall mounting is not possible—cannot be fitted retroactively

For cabinet width	440	562	800	440	800	440	562	800
For cabinet height	698	698	698	998	998	1298	1298	1298
Load capacity per drawer	35 kg	35 kg	50 kg	35 kg	50 kg	50 kg	50 kg	50 kg
& order no.	+ 6400-01	+ 6700-01	+ 6900-01	+ 6400-01	+ 6900-01	+ 6400-01	+ 6700-01	+ 6900-01
& addtl. charge								



# Asisto

## Drawer cabinets, 600 mm deep.



Order no. 146224-321



Order no. 146243-322  
& 69011-000 (MCPB top cover, optional)

### Dimensions and panel material of card-index cabinets, 600 mm deep

For **DIN A4** and **DIN A3** index cards, drawers fully extendable, incl. 7 mm-thick steel top cover

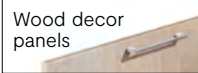

Depth: 600  	Height	698	998	1298
	Width	440	440	440
	Interior dimensions, HxWxD	285 x 300 x 518	285 x 300 x 518	285 x 300 x 518
	Rows	1-row	1-row	1-row
	Drawers	<b>2 x 6 HU</b>	<b>3 x 6 HU</b>	<b>4 x 6 HU</b>
	For index cards	<b>DIN A4 landscape</b>	<b>DIN A4 landscape</b>	<b>DIN A4 landscape</b>
	Order no.	146275-221	146245-321	146225-421
Price				

Wood decor panels 	Optional:			
	& order no.	+ 6400-410	+ 6400-411	+ 6400-412
	& addtl. charge			

→ **Body and panel color (for steel panels)**

Color concept → p. 48

→ **Panel/top decor (wood decor panels)**

Color concept → p. 50







Company

Color concept

Changing room & wardrobe

Workshop & factory

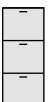
Office & archive

				
698	998	1298	1298	1298
800	800	800	562	562
285x300x518	285x300x518	285x300x518	390x429x518	390x214x518
2-row	2-row	2-row	1-row	2-row
<b>2x6 HU</b>	<b>3x6 HU</b>	<b>4x6 HU</b>	<b>3x8 HU</b>	<b>3x8 HU</b>
DIN <b>A4 landscape</b>	DIN <b>A4 landscape</b>	DIN <b>A4 landscape</b>	DIN <b>A3 landscape</b>	DIN <b>A4 portrait</b>
146273-222	146243-322	146223-422	146224-321	146224-322

\*Cabinet heights incl. MCPB tops + 18 mm in each case

+ 6900-410	+ 6900-411	+ 6900-412	+ 6700-412	+ 6700-412
------------	------------	------------	------------	------------

MCPB = Melamine coated particle board

**+** **Tops covers\***  
MCPB (wood decor) instead of steel top → p. 430

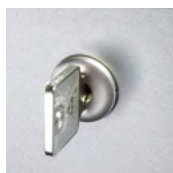

**+** **Accessories**  
Central locking system with exchangeable cylinder → p. 430  
Compatible with many other C+P furniture items. Also ideal for subsequent organization of locking groups.

# Asisto

## Drawer cabinets, 600 mm deep.

### Dimensions and panel material

#### Card-index cabinets, 600 mm deep

For **DIN A5 index cards**, drawers fully extendable, incl. 7 mm-thick steel top cover

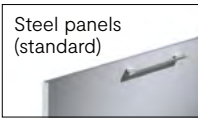

 Steel panels (standard)	Depth: 600	Height	698	1298	698	1298
		Width	562	562	800	800
		Interior dimensions, HxWxD	185 x 214 x 518	185 x 214 x 518	185 x 214 x 518	185 x 214 x 518
		Rows	2-row	2-row	3-row	3-row
		Drawers	<b>3 x 4 HU</b>	<b>6 x 4 HU</b>	<b>3 x 4 HU</b>	<b>6 x 4 HU</b>
		For index cards	<b>DIN A5 landscape</b>	<b>DIN A5 landscape</b>	<b>DIN A5 landscape</b>	<b>DIN A5 landscape</b>
		Order no.	146274-322	146224-622	146273-323	146223-623
		Price				

 Wood decor panels	Optional:				
	& order no.	+ 6700-410	+ 6700-412	+ 6900-410	+ 6900-412
	& addtl. charge				

### Dimensions and panel material

#### Card-index cabinets, 600 mm deep

For **DIN A6 index cards**, drawers fully extendable, also for **microfilm jackets/microfiches**, incl. 7 mm-thick steel top cover

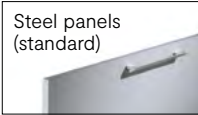

 Steel panels (standard)	Depth: 600	Height	698	998	1298	698
		Width	440	440	440	800
		Interior dimensions, HxWxD	130 x 155x518	130 x 155 x 518	130 x 155 x 518	130 x 155 x 518
		Rows	2-row	2-row	2-row	4-row
		Drawers	<b>4 x 3 HU</b>	<b>6 x 3 HU</b>	<b>8 x 3 HU</b>	<b>4 x 3 HU</b>
		For index cards	<b>DIN A6 landscape</b>	<b>DIN A6 landscape</b>	<b>DIN A6 landscape</b>	<b>DIN A6 landscape</b>
		Order no.	146275-422	146245-622	146225-822	146273-424
		Price				

 Wood decor panels	Optional:				
	& order no.	+ 6400-410	+ 6400-411	+ 6400-412	+ 6900-410
	& addtl. charge				

\*Cabinet heights incl. MCPB tops + 18 mm in each case

→ **Body and panel color (for steel panels)**

Color concept → p. 48

→ **Panel/top decor (wood decor panels)**

Color concept → p. 50



Order no. 146224-622



Order no. 146223-824



998

1298

800

800

130 x 155 x 518

130 x 155 x 518

4-row

4-row

**6 x 3 HU**

**8 x 3 HU**

**DIN A6 landscape**

**DIN A6 landscape**

146243-624

146223-824

+ 6900-411

+ 6900-412

**+ Tops covers\***

MCPB (wood decor) instead of steel top → p. 430

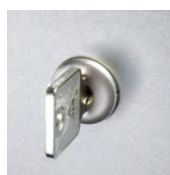

**+ Accessories**

Central locking system with exchangeable cylinder → p. 430

Compatible with many other C + P furniture items. Also ideal for subsequent organization of locking groups.

! All dimensions in mm, and all prices in Euros



# Asisto

## Drawer cabinets with special fittings, 600 mm.

### Dimensions and panel material

Drawers fully extendable, suitable for **CDs/DVDs** in W 142xD 10xH 125 mm format (jewel case), or W 142xD 5xH 125 mm (slim case), incl. 7 mm-thick steel top cover



Depth: 600	Height	698	1298
	Width	800	800
	Interior dimensions, HxWxD	185 x 154 x 514	185 x 154 x 514
	Rows	4-row	4-row
	Drawers	<b>3 x 4</b> HU	<b>6 x 4</b> HU
	Capacity	360 jewel cases or 720 slim cases	720 jewel cases or 1,440 slim cases
	Order no.	146273-324	146223-624
	Price		

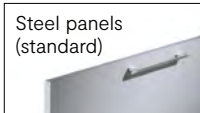

Interior fittings for CDs/DVDs in jewel case



Optional:		
& order no.	+ 6900-410	+ 6900-412
& addtl. charge		

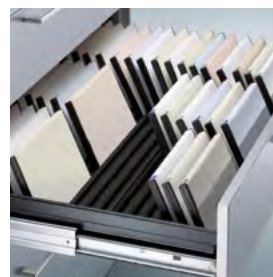

### Dimensions and panel material

Drawers fully extendable, for **microfilm roll boxes\*** of size 16 or 35 mm, incl. 7 mm-thick steel top cover  
Box capacity per drawer:  
16 mm film roll: 108 pc.  
35 mm film roll: 60 pc.



Depth: 600	Height	998	1298
	Width	800	800
	Interior dimensions, HxWxD	135 x 100 x 485	135 x 100 x 485
	Rows	6-row	6-row
	Drawers	<b>6 x 3</b> HU	<b>8 x 3</b> HU
	Order no.	146243-600	146223-800
	Price		



Please specify your project requirements when inquiring about cabinets with interior fittings for DVDs in the W 135xD 14xH 190 mm format!



Optional:		
& order no.	+ 6900-411	+ 6900-412
& addtl. charge		

Tray for microfilm roll boxes

\*Drawer cabinets for jackets/microfiches of size DIN A6, see p. 426/427

→ **Body and panel color (for steel panels)**

Color concept → p. 48

→ **Panel/top decor (wood decor panels)**

Color concept → p. 50



Company

Color concept

Changing room &amp; wardrobe

Workshop &amp; factory

Office &amp; archive

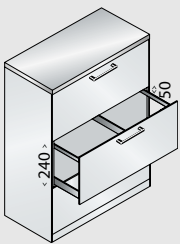

Our interior dimension specifications generally indicate **the usable dimensions** (e.g. from the suspension point of the DIN A4 size suspension file to the next lower panel or drawer bottom).

The usable dimensions from the suspension point to the next **higher** panel are indicated in the drawing on the left.

1 HU = 50 mm

MCPB = Melamine coated particle board

Cabinet heights incl. MCPB top + 18 mm in each case

⊕ **Tops covers\***

MCPB (wood decor) instead of steel top → p. 430

# Asisto

## Accessories for drawer and filing cabinets.

For 435 mm-deep cabinets

### Card-index dividers, single

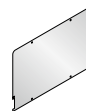

	For DIN <b>A5</b> <b>landscape</b> index cards	For DIN <b>A4</b> <b>landscape</b> index cards
Panel height	4 HU	6 HU
Order no.	146000-750	146000-740
Price		

### Alternative top covers

As solid-core/HPL top, instead of the MCPB top

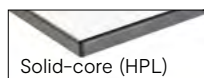

	800	1200
For cabinet width		
Depth	435	435
Thickness	13	13
Order no.	140003-130	140001-130
& addtl. charge		

### Dividers



	<b>Vertical fixed link</b> For reducing the track width of the hanging frame	<b>Index row plates</b> 1 set (2 pc.), suitable for all models with full drawer bottoms
Length	330	312
Order no.	146000-707	146000-706
Price		

For 435 and 600 mm-deep cabinets

### Label holder



Made of plastic, per piece



	<b>Standard</b> For supplementing the supplied inscription fields (1 per drawer as standard). Color black, incl. label and transparent cover	<b>Comfort</b> As an alternative to additional drawer labeling. Color black, incl. label and transparent cover	
Version	Self-adhesive	Self-adhesive	Magnetic
H x W x D	26 x 76 x 4	39 x 114 x 5	39 x 114 x 5
Window, H x W	17 x 67	30 x 105	30 x 105
Order no.	6103-13	6103-11	6103-12
Price			



### Exchangeable lock cylinder

With 2 keys, nickel-plated



Order no.	2025-02
Price	

### Single/ spare key

Per pc.

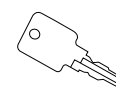

Order no.	0005-10
Price	



## For 600 mm-deep cabinets

### Card-index dividers, single

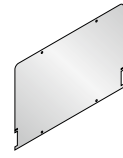
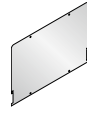

	For DIN <b>A6</b> landscape index cards	For DIN <b>A5</b> landscape index cards	For DIN <b>A4</b> landscape index cards	For DIN <b>A4</b> portrait index cards	For DIN <b>A3</b> landscape index cards
Panel height	3 HU	4 HU	6 HU	8 HU	8 HU
Order no.	6496-10	6495-10	6494-10	6494-20	6493-10
Price					

### Alternative MCPB tops

Instead of the 7 mm-thick steel top cover

Width	440	562	800
Depth	600	600	600
Thickness	25	25	25
Order no.	64011-000	67011-000	69011-000
& addtl. charge			

### Underframes

150 mm high, steel tube, adjustable level. Black gray RAL 7021, other colors on request



Height	150	150	150
Width	440	562	800
Order no.	146200-700	146200-701	146200-702
Price			

### Soft-stop

For an even softer self-closing system

Version	Per drawer
Order no.	146000-705
& addtl. charge	



### Dividers



	Vertical fixed link For reducing the track width of the hanging frame	Index row plates 1 set (2 pc.), suitable for all models with full drawer bottoms
Length	520	527
Order no.	146200-710	6492-00
Price		

### HD rail guide (heavy duty)

For an even higher load capacity

Version	Per drawer	Per drawer incl. soft-stop
Order no.	146000-704	146000-703
& addtl. charge		



HPL = High-pressure laminate



## 7100 and 7200 series Multi-drawer cabinets.

Multi-drawer cabinets from C+P know how to inspire. They can be used for just about any desired custom solution, not least thanks to their stepped horizontal and vertical dividers. Only available from C+P.

The cabinet with 10 drawers in one and the same body is another specialty from C+P, just like the trouble-free space-saving storage of up to 15 drawers (per cabinet with a height of 760 and 420 mm)—also on base and with MCPB top on request.







Company

Color concept

Changing room & wardrobe

Workshop & factory

Office & archive

For every application.



For watches (with C+P foam rubber mat)



For coins



For sample collections (with C+P dividers)



For office supplies (with C+P dividers)



For miniatures



For screw/mounting accessories



For collections (with C+P aluminum dividers)



# 7100 and 7200 series

## Multi-drawer cabinets.

### Features of the multi-drawer cabinets of the 7000 series:

**The universal drawer cabinets for everything flat,**

e.g. drawings, plans, pictures, prints, graphics, collections, medication, small parts and lots more.

- + Sturdy steel construction with overlay drawer fronts and high-quality enamel coating
- + Many combination options thanks to optional base and top covers
- + With sliders for floor protection as standard
- + Elegant and ergonomic bow-shaped handles, matt nickel-plated
- + Central locking system with 2 keys (cylinder lock with exchangeable cylinder)
- + Drawer with self-closing system, fully (DIN A1) or 4/5 (DIN A0) extendable, with anti-tilt mechanism
- + All drawers with pressure device at the front and with cover strip at the back
- + Load capacity per drawer: 40 kg
- + Drawer bottoms are stepped and can be divided, therefore suitable for different applications
- + Available in two sizes (DIN A1 and DIN A0) and two cabinet heights with different drawer configurations
- + Per drawer: 1 transparent label holder with white label as standard

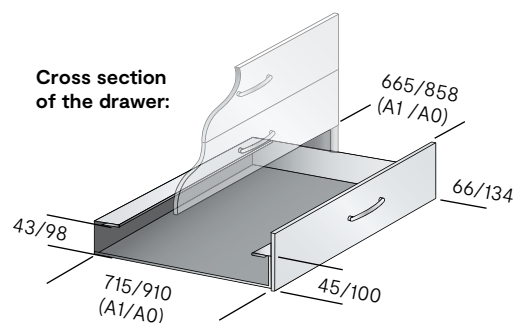

### Explanation of the interior dimensions:

Standard version

- 45 mm = Height of the drawer **pan**
- 43 mm = Internal height of the drawer **pan**
- 66/134 mm = Exterior panel height (regular/double panel height)
- 55/120 mm = Internal height of the drawer (regular/double panel height)

Version with high drawer pan and double panel height

(addtl. charge for model 7000-80, see bottom of Page 436)

- 100 mm = Height of the drawer **pan**
- 98 mm = Internal height of the drawer **pan**
- 134 mm = Exterior panel height
- 120 mm = Internal height of the drawer

C+P multi-drawer cabinets in an archive on a customer's rolling shelving system





Order no. 7100-000 & 7101-000  
& 7105-000 (top cover)  
& 7103-000 (base)



Order no. 7101-000  
& 7105-000 (top cover)  
& 7103-000 (base)

## Dimensions and version

**7100 series** for sizes up to **DIN A1**,  
central locking,  
with **fully** extendable drawers



Depth: 765	Height	420	420	760	760	760
	Width	1100	1100	1100	1100	1100
	Drawer interior dimensions, HxWxD	45/55 x 1005 x 710	45/55/120 x 1005 x 710	45/55 x 1005 x 710	45/120 x 1005 x 710	45/55/120 x 1005 x 710
	Description	5 drawers with regular panel height	3 drawers, 1 with regular panel height, 2 with double height	10 drawers with regular panel height	5 drawers with double panel height	8 drawers, 6 with regular panel height, 2 with double height
	Order no.	7100-000	7100-100	7101-000	7101-100	7101-200
	Price					

**7200 series** for sizes up to **DIN A0**,  
central locking,  
with **4/5** extendable drawers



Depth: 960	Height	420	420	760	760	760
	Width	1350	1350	1350	1350	1350
	Drawer interior dimensions, HxWxD	45/55 x 1255 x 905	45/55/120 x 1255 x 905	45/55 x 1255 x 905	45/120 x 1255 x 905	45/55/120 x 1255 x 905
	Description	5 drawers with regular panel height	3 drawers, 1 with regular panel height, 2 with double height	10 drawers with regular panel height	5 drawers with double panel height	8 drawers, 6 with regular panel height, 2 with double height
	Order no.	7200-000	7200-100	7201-000	7201-100	7201-200
	Price					

→ **Body and frame color**

Color concept → p. 48

+ **Accessories**

Selection → p. 436



# 7100 and 7200 series

## Accessories for multi-drawer cabinets.

### Top covers, bases and underframes

For 7100 series,  
DIN A1 drawers

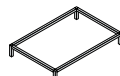
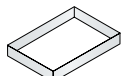
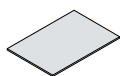

**MCPB top**  
Approx. 25 mm thick  
(please specify decor,  
for decor overview, see  
page 52)

**Base**  
For compartment with  
drawers, grips into  
the cabinet bottom  
all the way around,  
recessed approx. 15 mm  
in front, please specify color

**Underframe**  
Made of square tube  
without intermediate shelf,  
please specify color

**Underframe**  
Made of square tube  
with an  
intermediate shelf,  
please specify color

Dimensions, H x W x D	25 x 1100 x 765
Order no.	7105-000
Price	

Dimensions, H x W x D	100 x 1100 x 750
Order no.	7103-000
Price	

Dimensions, H x W x D	150 x 1100 x 750
Order no.	7106-000
Price	

Dimensions, H x W x D	445 x 1100 x 750
Order no.	7104-000
Price	

For 7200 series,  
DIN A0 drawers

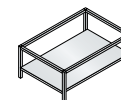
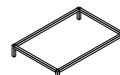
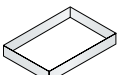
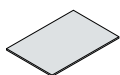

**MCPB top**  
Approx. 25 mm thick  
(please specify decor,  
for decor overview,  
see Page 52)

**Base**  
For compartment with  
drawers, grips into  
the cabinet bottom  
all the way around,  
recessed approx. 15 mm  
in front, please specify color

**Underframe**  
Made of square tube  
without intermediate shelf,  
please specify color

**Underframe**  
Made of square tube  
with an  
intermediate shelf,  
please specify color

Dimensions, H x W x D	25 x 1350 x 960
Order no.	7205-000
Price	

Dimensions, H x W x D	100 x 1350 x 945
Order no.	7203-000
Price	

Dimensions, H x W x D	150 x 1350 x 945
Order no.	7206-000
Price	

Dimensions, H x W x D	445 x 1350 x 945
Order no.	7204-000
Price	

### Compartment dividers

For DIN A1 drawers



Number of compartments  
Maximum compartment  
dimensions per divider, W x D  
Order no.  
Price

Number of compartments	<b>2 x DIN A2</b>
Maximum compartment dimensions per divider, W x D	620 x 440
Order no.	0102-00
Price	

Number of compartments	<b>4 x DIN A3</b>
Maximum compartment dimensions per divider, W x D	500 x 340
Order no.	0104-00
Price	

Number of compartments	<b>8 x DIN A4</b>
Maximum compartment dimensions per divider, W x D	245 x 340
Order no.	0108-00
Price	

Order no. 0108-00

### Compartment dividers

For DIN A0 drawers

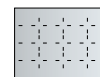
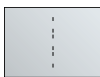

Number of compartments  
Maximum compartment  
dimensions per divider, W x D  
Order no.  
Price

Number of compartments	<b>2 x DIN A1</b>
Maximum compartment dimensions per divider, W x D	620 x 890
Order no.	0202-00
Price	

Number of compartments	<b>4 x DIN A2</b>
Maximum compartment dimensions per divider, W x D	620 x 440
Order no.	0204-00
Price	

Number of compartments	<b>8 x DIN A3</b>
Maximum compartment dimensions per divider, W x D	305 x 440
Order no.	0208-00
Price	

Number of compartments	<b>16 x DIN A4</b>
Maximum compartment dimensions per divider, W x D	305 x 220
Order no.	0216-00
Price	

### Drawer pans

**Height of 100 mm\*** for drawers with double panel height in models 7100/7200-100 and 7101/7201-100/200. Additional charge per drawer (for explanation of the interior dimensions, see page 434)

Order no.	7000-80
Price	

### Compartment dividers

Single, max. fill height  
up to pressure device:  
approx. 4 cm

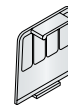
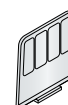

Application	Used <b>vertically</b> , without pressure device	Used <b>horizontally</b> , with pressure device
Order no.	7000-10	7000-20
Price		

\*Longer delivery time possible.

## Drawer dividers

Made of sturdy plastic, color gray, with approx. 20 mm steps

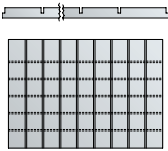
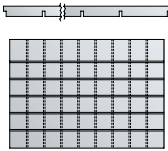

	Vertical divider For insertion into horizontal divider	Horizontal divider For insertion into vertical divider
		
Dimensions, HxWxD	40x5x702	40x1003x5
Order no.	7100-704	7100-705
Price		



Order no. 7100-704 & 7100-705

## Drawer tidies

Plastic boxes for small parts

	For mod. 7100/7101	With 7 vertical aluminum rails, 5 transparent horizontal dividers per rail, <b>each row steplessly adjustable</b> , for quick and flexible configuration
		
For drawer	DIN A1	DIN A1
Description	20 boxes each: 198 x 99 mm 99 x 99 mm 49 x 49 mm 10 boxes: 99 x 49 mm All 40 mm high	7 horizontal rows 6x145 mm row width 1x90 mm row width Height: 35 mm
Order no.	7100-5051	7100-709
Price		





Order no. 7100-5051



Order no. 7100-709

## Foam rubber mat

3 mm thick

		
For drawer	DIN A1	DIN A0
Dimensions, WxD	1005 x 710	1255 x 905
Order no.	7100-706	7200-706
Price		



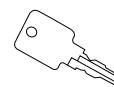

## Single/spare key



Order no.	0005-00
Price	

## Label holder

Made of plastic, per piece

	Label holder Transparent, incl. white label (1 pc. per drawer as standard)	Standard For supplementation of the included inscription fields. Color black, incl. label and transparent cover	Comfort As an alternative to additional drawer labeling. Color black, incl. label and transparent cover	
				
Version	Self-adhesive	Self-adhesive	Self-adhesive	Magnetic
HxWxD	32 x 100 x 2	26 x 76 x 4	39 x 114 x 5	39 x 114 x 5
Window, H x W	26 x 98	17 x 67	30 x 105	30 x 105
Order no.	6103-10	6103-13	6103-11	6103-12
Price				



# Office furniture & accessories

---



## Counters and lounge furniture

### The right furniture for THE NEW WORLD OF WORKING

The way we work is changing. Coziness and an atmosphere of well-being in the office are playing an increasingly important role. More and more, the office of today is becoming a living room where lounge and meeting furniture are supplementing the classic desk and workstation.

#### What you'll find in this section:

- + Customized solutions for reception counters
- + Basic standing tables as a "moving" meeting point
- + Asisto lounge furniture as a place to retreat to for concentrated work and informal meetings

## Tables

### The contemporary work and meeting solutions

Whether it's ergonomic sit/stand workstations or smart solutions for meetings: Contemporary office tables of today have to offer more than function and efficiency. Like tables from C+P, which come in an attractive selection of colors and decors, among other things.

#### What you'll find in this section:

- + Electric height adjustment Asisto sit/stand tables
- + Asisto occasional tables with fixed or adjustable height
- + Asisto folding tables as a mobile, nestable version
- + Basic cafeteria tables and folding tables



## Around the desk

### Welcome additions for working better

The difference is in the details! The right parameters in the work environment have a major influence on well-being and motivation—and therefore on the results of work. Whether it's the addition of thinking lighting, the acquisition of privacy sections or optimization of the monitor position: These investments always pay off.

### What you'll find in this section:

- + Workstation dividers
- + Asisto light with active brightness control
- + Asisto monitor holders



## Chairs and stools

### The ergonomic swivel and task chairs

Healthy and pleasant sitting isn't just a decisive factor at the workplace. Chairs which not only look good, but also enable comfortable sitting, are also needed at meetings & seminars, for visits and for meetings at the office counter.

### What you'll find in this section:

- + Basic workstation swivel chair
- + Asisto office swivel chair with 3D knitted membrane
- + Basic and Asisto visitor chairs
- + Basic and Asisto stackable chairs
- + Bar stools



## Cabinets, pedestals and caddies

### The experts for storage space and flexible catering near the workstation

Everything at hand and in the right place in the right pull-out cabinet or pedestal: Naturally, made of steel with long-lasting and convenient pull-outs, nearly unlimited color variety and an impressive appearance and technology. This also applies for C+P fridge caddies, which provide perfect service in the conference area.

### What you'll find in this section:

- + Asisto pull-out cabinets at standing and sitting height
- + Asisto mobile pedestals
- + Asisto fridge caddies



## Reception counter

# Design meets function and expression.

The reception counter is the first piece of furniture at your company that people see. That's why it's all the more important that you design this area in line with your tastes and your company's image. C+P has an extensive portfolio:

- + Reception solutions for every need
- + Stylish business cards for the entrance area of any company
- + Also for clinics, institutes, public facilities and lots more
- + Available in a wide variety of different surfaces, colors and versions
- + Made of sturdy and high-quality materials

Whether it's light or dark, modern or timeless: The choice is yours, and you'll be delighted at how your new counter influences the effect of the space and creates a positive impression.

**Ask us about your customized reception counter—we look forward to handling your task!**





Company

Color concept

Changing room & wardrobe

Workshop & factory

Office & archive

# Basic

## Standing tables.

**The Basic standing table keeps the body in motion and the thoughts flowing.**

Basic—keeps the body in motion and the thoughts flowing. Meetings held standing are generally shorter and thereby promote work efficiency.

For short meetings, an exchange of ideas, brainstorming, collecting information or a coffee break, the Basic standing table makes communication zones possible in large offices.

- + Sides and tabletop are always made of sturdy 38 mm-thick panels
- + All surfaces are coated with high-quality, durable HPL
- + Sides each feature 2 floor-compensating adjustable feet for easy leveling
- + Connection between side and tabletop with 5 mm shadow gap in silver
- + Delivered disassembled with easy assembly instructions
- + **The decor of the work top is your choice, and the side & connection crossbar are always diamond white**



### Dimensions and versions

Size	1.600 x 800	2.000 x 800	2.400 x 800
Height	1.100	1.100	1.100
For no. of people	4 people	6 people	8 people
Order no. (for work top decor diamond white)	99001-0025-183	99001-0026-183	99001-0027-183
Price			
Surfaces	HPL surface	HPL surface	HPL surface

Top decor of work top	Decor no.
Diamond white	-183
Light gray	-002
Royal maple	-053
Light acacia	-062
Basalt oak	-189
Light concrete	-185

The specified product order no. includes the first work top decor of the decor chart at the end (diamond white, decor no. -183). All other work top decors are available at no additional charge—simply change the decor no. at the end of the product order no.





Company

Color concept

Changing room & wardrobe

Workshop & factory

Office & archive



Light acacia



Concrete



Basalt oak



Royal maple



# Asisto Lounge.

## Features of the Asisto lounge sofas:

- + Ideal supplement for the reception, lounge or central zone
- + Currently available as a sofa and highback in 3 widths
- + 5 materials from the FENICE collection can be combined

The way we work is changing. On the one hand, day-to-day work is getting faster all the time and requirements on each individual are increasing. On the other hand, coziness and an atmosphere of well-being play an important role at the office. Relaxation and the ability to retreat are utilized to develop new energies and creativity.

More and more, the office of today is becoming a living room where lounge and meeting furniture are supplementing the classic desk and workstation.

The Asisto lounge offers a visual and acoustic space to retreat to for concentrated work.



## Dimensions and versions



Model	2-seaters	2-seaters MAX	3-seaters
Version	2-seater sofa with low sides and back	2-seater sofa WIDE with low sides and back	3-seater sofa with low sides and back
Width	1410	1810	2045
Height	870	870	870
Upholstered backrest	Freely selectable and combinable, order no. for upholstered backrest material color light green: 41		
Upholstered seat	Freely selectable and combinable, order no. for upholstered seat material color dark green: -042		
Order no.	99001-0141-042	99001-0241-042	99001-0341-042
Price			

- + All lounge furniture features sturdy powder-coated steel tube framing on round plastic sliders, black
- + Version always features upholstered sides and back panels
- + Material selection from the FENICE collection, as per the EU Ecolabel
- + One loose back cushion for increased sitting comfort per seat, always in the seat upholstery color
- + Internal structure made of reinforced laminated wood
- + Seat height: 460 mm
- + Other shapes, combinations, materials, versions and electrification options on request



## Dimensions and versions



Model	2-seaters	2-seaters MAX	3-seaters
Version	2-seater sofa with high sides and back	2-seater sofa WIDE with high sides and back	3-seater sofa with high sides and back
Width	1410	1810	2045
Height	1310	1310	1310
Upholstered backrest	Freely selectable and combinable, order no. for upholstered backrest material color sand: 52		
Upholstered seat	Freely selectable and combinable, order no. for upholstered seat material color orange: -012		
Order no.	99001-0452-012	99001-0552-012	99001-0652-012
Price			

## Colors/Materials (see number code)

FENICE material	Upholstered backrest	Upholstered seat
Orange	12	-012
Light green	41	-041
Dark green	42	-042
Sand	52	-052
Red	21	-021



**Number code in example**  
99001-0421-021  
(see figure to left)

**Basic number:**  
99001-0421-021

**Upholstered backrest:**  
99001-0421-021

**Upholstered seat:**  
99001-0421-021

+ Other material colors and combinations on request

# Asisto

## Sit/stand tables.

### The affordable sit/stand tables for diverse office tasks

- + T-foot frame made of sturdy steel rectangular tubing
- + **Electric** height adjustment (40 mm/sec), with enhanced collision protection as per DIN
- + Double telescopic extension with sit/stand height of **625 – 1,285 mm**
- + Table load capacity up to 100 kg
- + Available in 3 attractive frame colors
- + Tabletop in MCPB, optionally with high-quality Synchro surface
- + Delivered fully assembled, frame collapsible for easier transport and storage
- + Economical and ergonomic sit/stand table promotes movement, reduces downtime costs and motivates employees

### Dimensions and versions

Rectangular bottom frame, electric height adjustment from 625 – 1,285



Height: 625 – 1,285 Depth: 800	Width	1600	1800	2000
MCPB top, 25 mm (standard)	Order no.	540490-1.1	540490-1.10	540490-1.8
	Price			
Synchro decor, 25 mm	& order no.	+ 540708-1.1	+ 540708-1.10	+ 540708-1.8
	& addtl. charge			

#### Frame/runner color

- Traffic white
- White aluminum
- Black gray metallic

**+** Exclusive height adjustment  
With memory control,  
height indicator and 2x USB

& order no.	On request
& addtl. charge	On request



**+** Cable aperture sockets  
80 mm dia., installed in  
tabletop at factory

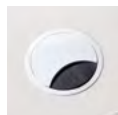

Installation location	Version	White plastic	Black plastic	Metal
Left	Order no.	540700-721L	540700-722L	540700-707L
	Price			
Center	Order no.	540700-721M	540700-722M	540700-707M
	Price			
Right	Order no.	540700-721R	540700-722R	540700-707R
	Price			





- + **Sheet metal cable duct**  
Folds down in front and back, lockable at 2 heights, hole in center for triple socket

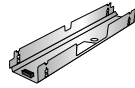

For desk width	1600	1800	2000
Order no.	540700-7084	540700-7085	540700-7086
Price			

- + **Sockets and wiring**



Version	Triple socket strip	GST-18 supply line, 3 m	GST-18 extension, 3 m
Order no.	540700-713	540700-715	540700-717
Price			

- + **Netboxes with various power, data and communication connections on request**



- **Top decor**

Color concept → p. 52

- + **Other accessories on request**









# Asisto

## Occasional tables.

### The affordable meeting tables for diverse office tasks:

- + Sturdy foot frame made of thick-walled steel tube
- + Fixed heights of 720 and 1,100 mm
- + Or with height adjustment of 700 – 1,135 mm, depending on the lifting technology
- + Available in 3 attractive frame colors
- + Tabletops in MCPB
- + Delivered fully assembled

Tabletop decors	Decor no.
 <b>Diamond white</b>	<b>-183</b>
 Light gray	-002
 Royal maple	-053
 Light acacia	-062
 Basalt oak	-189
 Concrete	-185

The specified product order no. includes the first decor of the decor chart at the end (diamond white, decor no. -183). All other decors are available at no additional charge—simply change the decor no. at the end of the product order no.

### Dimensions and version

**Meeting table SQUARE**  
25 mm tabletop  
Base plate and foot tube  
Square



Height	720	1.100	700 - 1.135
Size	800x800	800x800	800x800
Version	Fixed height	Fixed height	Lifting technology

Frame color 	White aluminum		
Order no. (for diamond white decor)	99001-0001-183	99001-0004-183	99001-0007-183
Price			

Frame color 	Traffic white		
Order no. (for diamond white decor)	99001-0002-183	99001-0005-183	99001-0008-183
Price			



Frame color 	Black gray metallic		
Order no. (for diamond white decor)	99001-0003-183	99001-0006-183	99001-0009-183
Price			



## Dimensions and version

**Meeting table ROUND**  
25 mm tabletop  
Base plate and foot tube, round



Height	720	1.100	700 - 1.135
Size	Ø 800	Ø 800	Ø 800
Version	Fixed height	Fixed height	Lifting technology
Frame color 	White aluminum		
Order no. (for diamond white decor)	99001-0010-183	99001-0013-183	99001-0016-183
Price			
Frame color 	Traffic white		
Order no. (for diamond white decor)	99001-0011-183	99001-0014-183	99001-0017-183
Price			
Frame color 	Black gray metallic		
Order no. (for diamond white decor)	99001-0012-183	99001-0015-183	99001-0018-183
Price			

# Asisto

## Mobile folding table.

### The flexible solution for seminars and meetings:

- + Easy to operate folding mechanism with a bar under the front edge of the tabletop for one-handed operation
- + Foldable table frame, for space-saving nesting
- + Frame color: Silver aluminum
- + 2 table top grid sizes in 6 standard decors each
- + 720 mm high
- + MCPB tabletops, with standard edge band or rounded with rubber edge for better impact resistance
- + Delivered fully assembled

### Dimensions and version

#### With edge band

MCPB tabletop, rectangular  
Table height: 720, on casters, foldable, silver aluminum frame



Size	1400 x 700	1600 x 800
Height	720	720
Version	Foldable/Nestable	Foldable/Nestable
Table top edge	Edge bands	Edge bands
Order no. (for diamond white decor)	99001-0019-183	99001-0020-183
Price		

#### With rubber edge

MCPB tabletop, rounded  
Table height: 720 mm, on casters, foldable, silver aluminum frame



Size	1400 x 700	1600 x 800
Height	720	720
Version	Foldable/Nestable	Foldable/Nestable
Table top edge	With rubber	With rubber
Order no. (for diamond white decor)	99001-0021-183	99001-0022-183
Price		











## Accessories

### Modesty panel

For easy assembly

Width	1400	1.600
Size	1040 x 250	1240 x 250
Version	Foldable/Nestable	Foldable/Nestable
Order no. (for diamond white decor)	99001-0023-183	99001-0024-183
Price		

Tabletop decors	Decor no.
 <b>Diamond white</b>	<b>-183</b>
 Light gray	-002
 Royal maple	-053
 Light acacia	-062
 Basalt oak	-189
 Concrete	-185

The specified product order no. includes the first decor of the decor chart at the end (diamond white, decor no. -183). All other decors are available at no additional charge—simply change the decor no. at the end of the product order no.



# Basic

## Cafeteria tables.

### 4-foot tables:

Multi-purpose tables from C + P meet a variety of needs. They can be used as meeting tables, as storage space and as workspace. The steel frame of the multi-purpose tables isn't just very robust, but has a timeless and minimalist effect as well:

- + Tabletop: 25 mm thick with 3 mm edge band, light gray decor
- + Steel underframe with 30x30 mm square legs, light gray RAL 7035
- + Level adjustable by 25 mm
- + Load capacity of max. 100 kg with evenly distributed load
- + Tables are delivered disassembled, but are easy to assemble!
- + Dimensions, (HxWxD): 750 x 1,200 – 1,800x800 mm

### Dimensions and version

Steel tube frame RAL 7035, light gray MCPB tabletop



Size	1.200 x 800	1.600 x 800	1.800 x 800
Height	750	750	750
Version	Disassembled	Disassembled	Disassembled
Order no.	99699-00001	99699-00002	99699-00003
Price			

### Folding tables:

- + Folding table frame made of chrome-plated round tube with folding mechanism, stackable
- + Table height: 750 mm (folded only 125 mm)
- + Durable, melamine-coated tabletop (25 mm thick) with edge band

### Dimensions and versions

Chrome-plated round-tube frame, 30 mm dia., quick setup thanks to special folding mechanism, stackable for space-saving storage,

height: 750 mm (folded: 125 mm)

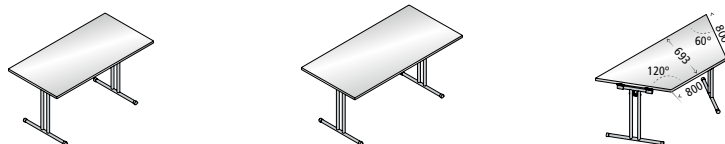

 MCPB, 25 mm (standard)	Width	1400	1600	1600/800
	Depth	700	800	800/693
	Order no.	51022-1.9	51022-1.1	51022-2.10
	Price			

→ **Top decor**  
(for folding tables only)

Color concept → p. 52





Company

Color concept

Changing room & wardrobe



Workshop & factory

Office & archive



# Workstation dividers

## Features of the privacy element:

- + Privacy with improved direct speech acoustics
- + Table-back element, rigid
- + Height: 800 mm, 200 mm projection under top edge of tabletop
- + Planked support panel/honeycomb panel, corner radius: R40, depth: 25 mm
- + Attached with spacing of 10 mm to tabletop
- + Lucia fabric cover (colors as per LUCIA fabric card) featuring quilting seams
- + Wall thickness: approx. 28 mm
- + Incl. holder set for tabletop clamping (for 10 mm spacing)

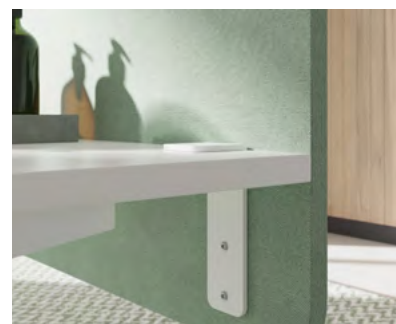

## Dimensions and versions











Width	1600	1800	2000
Height	800	800	800
Surfaces	LUCIA fabric	LUCIA fabric	LUCIA fabric
Holder color	White aluminum	White aluminum	White aluminum
Order no. (for fabric color rum)	99001-0043-086	99001-0044-086	99001-0045-086
Holder color	Traffic white	Traffic white	Traffic white
Order no. (for fabric color rum)	99001-0046-086	99001-0047-086	99001-0048-086
Holder color	Black gray metallic	Black gray metallic	Black gray metallic
Order no. (for fabric color rum)	99001-0049-086	99001-0050-086	99001-0051-086
Price			



The stand-up wall system offers ideal privacy and fits into a harmonious overall picture thanks to its lightness. With its rounded corners the stand-up wall exhibits modern zeitgeist. It's available as a table back element, where the cable duct and cable channel are covered by the projection. A host of color variants are available for selection.

**+ Additional versions, surfaces and dimensions on request**

LUCIA fabric colors	Fabric no.
 <b>Rum (light gray)</b>	<b>-086</b>
 Havana (black)	-009
 Paseo (dark gray)	-019
 Sombrero (dark olive)	-046
 Solano (yellow)	-088
 Apple (light green)	-096
 Madura (bright green)	-056
 Marianna (light blue)	-057

Composition of LUCIA fabric:  
 100% recycled polyester  
 Dyes do not contain heavy metals  
 Environmentally friendly  
 In accordance with EU Ecolabel certificate  
 In accordance with OEKO-TEX® Standard 100 certificate  
 Made of 100% recycled polyester

The specified product order no. contains the first color of the fabric chart (rum, fabric no. -086) at the end. All other colors are available at no additional charge—simply change the fabric no. at the end of the product order no.



# Asisto Light.

## Features of ASISTO floor lamp SOLO:

- + LED floor lamp, single illumination, direct/indirect
- + With LRC (Luminosity Range Control, see description below)
- + Presence detector for maximum energy efficiency
- + Color temperature: 4,000 kelvin neutral white (daylight)
- + Protection type IP20
- + Lamp head rotatable 90° and telescopic
- + 24 volts (with 230-volt connection cable)/55 watts, standby: 0.5 watts
- + 3 colors



## Dimensions and versions

Color	Traffic white	Silver aluminum	Black gray
Values	4,000 kelvin/55 watts	4,000 kelvin/55 watts	4,000 kelvin/55 watts
Function	LRC & presence detector	LRC & presence detector	LRC & presence detector
Order no.	99001-0040-014	99001-0040-010	99001-0040-016

Price

The smart lamp system of the Asisto series complements the ergonomic workstation.

Newly developed active Luminosity Range Control ensures that the illumination angle and the illumination values are automatically adapted to the working height of sit/stand tables. Customized light scenes set by the user are retained at each table height.

LEDs of the lamp head are dimmed depending on the table height. This means that your eyes don't have to adjust to changing lighting conditions, but rather that the lighting conditions adjust to your eyes.

The light shines both up (indirect) and down. Dimmable adjustment is made using the display

A spotlight function for continuous constant light is integrated and can be selected using the operating panel



Company

Color concept

Changing room & wardrobe

Workshop & factory

Office & archive

# Asisto

## Monitor holders.

### Features of the Asisto monitor arm:

- + Single- or double-screen solution
- + Up to 27" in size and 7 kg in weight
- + Attachment standard VESA 75/100, incl. quick release
- + With gas lift and horizontal arm element
- + Toolless monitor changing
- + Sturdy, yet flat, pivot joint for nearly unlimited freedom of movement
- + Flexible attachment options thanks to 3-in-1 table attachment
- + Color: white, silver or black
- + Delivered disassembled for easy assembly



### Dimensions and versions

Type	SINGLE	SINGLE	SINGLE
Max. monitor size	27" / 7 kg	27" / 7 kg	27" / 7 kg
Range in mm	457	457	457
Color	White	Silver	Black
Order no.	99001-0041-023	99001-0041-025	99001-0041-026
Price			



Type	DUO	DUO	DUO
Max. monitor size	2 x 27" / 7 kg	2 x 27" / 7 kg	2 x 27" / 7 kg
Range in mm	333	333	333
Color	White	Silver	Black
Order no.	99001-0042-023	99001-0042-025	99001-0042-026
Price			





#### Smart cable duct

All connecting cables are routed neatly and protected under the unobtrusive cover. The powerful gas lift element for top-notch ease of operation is also found here.



#### Quick release

Monitors can easily be inserted or changed by one person by hand without any tools at all. The holder fits all common monitors with the 75 x 75 and 100 x 100 attachment standard.



#### Sturdy joint technology

The high-quality pivot joint is considerably flatter than a conventional ball joint, so it offers nearly unlimited freedom of movement in every turn and tilt direction. Large monitors can also be effortlessly handled and remain securely in the set position.



#### 3-in-1 table attachment

The standard attachment element can be conveniently secured from above and covers three mounting types in one: clamp, cable opening and drill hole attachment. It offers optimal flexibility should the attachment type be changed.



# Basic

## Workstation swivel chair.

### Features of the Basic office workstation chair:

- + Office swivel chair with load-dependent braked casters
- + Attractively shaped plastic base in black
- + Integrated synchronous mechanism for seat and backrest, 4 locking positions
- + Body weight adjustment in the mechanism between 45 and 120 kg
- + Functional seat depth adjustment (adjustment range: 50 mm)
- + Backrest with net fabric
- + Armrest height and depth adjustable in 3D
- + Height-adjustable lumbar support



### Dimensions and versions

	Fabric	Xtreme black
	Model	With 3D armrest
	Chair base	Black
	Height	1025–1155
	Seat height	418–539
	Width without/with armrests	480/635
	Depth	475
With soft casters	Order no.	99001-0030-002
	Price	
With hard casters	Order no.	99001-0030-001
	Price	

Xtreme is a modern fabric made of up to 100% recycled polyester. This prevents waste and conserves raw materials. Thanks to its stretch characteristics, flame-resistance, long service life and anti-pilling properties, Xtreme is ideal for use on chairs.

#### Composition

100% recycled flame-resistant polyester

Dyes do not contain heavy metals

Environmentally friendly

Made of 100% recycled polyester

In accordance with EU Ecolabel certificate

**Synchronous mechanism**

Seat and back tilt in sync. Sync ratio of backrest to seat is 2.4:1. Force of 45 to 129 kg using side level in just 2 turns. The mechanism has 4 locking positions.

**3D armrest**

Polyamide armrests with fiberglass and SoftTouch PU coating. Vertically adjustable, with depth-adjustable and swiveling support

**Lumbar**

Vertically adjustable lumbar support with flexible slats

**Soft casters**

(for hard floors)

**Hard casters**

(for soft floors)

# Asisto

## Office swivel chair.

### Features of the Asisto office swivel chair:

- + Dynamic synchronous mechanism
- + 5 plastic colors for back, mechanism cladding, armrests and base
- + Colorful overall design available in 5 colors
- + Seat always made of special molded PU foam with opaque knit fabric in 5 colors
- + 2D armrests, black
- + 2 back variants:
  - 3D knit back, transparent in 5 colors (net)
  - 3D knit back, opaque in 5 colors (comfort)
- + Version always features integrated lumbar support
- + 100 % recyclable due to modular principle
- + Made in Germany
- + Certified with the highest European sustainability certification level 3



### Dimensions and versions

	Color	LIGHT GRAY	Black gray
	Model	Office swivel chair	Office swivel chair
	Armrest	2D PP	2D PP
	Frame color/5-star base	3008 light gray	3004 black gray
With seat cover & 3D net back	Order no.	99001-3108-N03	99001-3104-N02
	Price		
With seat cover & 3D comfort back	Order no.	99001-3108-K03	99001-3104-K02
	Price		

#### The 3D knit membrane

This is precisely fit to the backrest and seat. It's various back zones are designed in such a way that the flexible functions of the backrest are optimally supported. In the lumbar area, it features greater tension than in the shoulder area, forming a perfect symbiosis together with the back design for comfortable sitting. The 3D knit membrane also contributes to sustainability.



Company

Color concept

Changing room & wardrobe

Workshop & factory

Office & archive



DARK RED

Office swivel chair

2D PP

3021 dark red

99001-3121-N05

99001-3121-K05

DARK GREEN

Office swivel chair

2D PP

3022 dark green

99001-3122-N04

99001-3122-K04

BLACK

Office swivel chair

2D PP

3005 black

99001-3105-N01

99001-3105-K01

All chairs are outfitted with soft casters for hard floors as standard, indicated by the -31 in the order number. If you change this number to -32, we will supply hard rollers for carpet at no additional charge.









# Visitor chairs



## Basic visitor chairs:

- + Cantilever chair with armrest, stackable
- + Steel tube frame, 25 mm dia., chrome-plated
- + Perforated backrest made of plastic in 2 colors
- + Upholstered seat with Xtreme fabric

Model	Basic (visitor chair)	
Upholstered seat fabric	Xtreme	
Version	Cantilever chair with armrest, stackable	
Frame	Steel tube, chrome-plated	
Back	Black	Silver gray
Order no. (for Havana fabric, black)	99001-0032-240	99001-0033-240
Price		

Xtreme fabric colors	Fabric no.
 Havana, black	-240
 Ocean, blue	-210
 Blizzard, gray	-220
 Scuba, navy blue	-226
 Costa, dark blue	-230
 Panama, red	-260
 Padang, black gray	-270

The specified product order no. contains the first color of the fabric chart (Havana, black, fabric no. -240) at the end. All other colors are available at no additional charge—simply change the fabric no. at the end of the product order no.



### Asisto visitor chairs:

- + Cantilever chair with armrest, stackable
- + Steel tube frame, powder-coated in 5 colors
- + Attractively shaped perforated backrest made of plastic in 5 colors
- + Upholstered seat with Asisto fabric same as frame color

Model	Asisto (visitor chair)				
Fabric seat upholstery	Asisto fabric				
Version	Cantilever chair with armrest, stackable				
Frame	Steel, powder-coated				
Back	Light gray	Black gray	Red	Green	Black
Order no.	99001-3505-N03	99001-3505-N02	99001-3505-N05	99001-3505-N04	99001-3505-N01
Price					



#### Asisto colors

19503 light gray	-N03
19502 black gray	-N02
19505 red	-N05
19504 green	-N04
19501 black	-N01

These colors are already encoded in the specified product order numbers.

# Stackable chairs

When chairs need to be set up and put away again quickly and with space in mind, stackable chairs are the right choice:

The all-plastic **Basic** model is the right alternative for anyone with high aesthetic demands and a limited budget.

Should you prefer an appealing steel frame and optional seat upholstery, **Asisto** is the right address.



Model	Basic	Asisto
Seat	PP	Anti-UV PP
Version	Stackable chair	Multi-purpose chair
Frame	Plastic, black	Steel, chrome-plated
Seat shell	Plastic	Plastic
Upholstered seat	-	-
Seat height	461	440
Total height	941	815
Seat width	526	450
Total width	526	540
Total depth	539	580
Order no. (for 1st color in color chart)	99001-0031-803	99001-0034-057
Price		

Colors	Basic seat shell	Color no.	Asisto seat shell	Color no.
	Olive	-803	White	-057
	White	-800	Red	-051
	Ocher	-801	Black	-056
	Light gray	-802	Gray	-054
	Light blue	-804		
	Pink	-805		
	Dark gray	-806		
	Terracotta	-807		

The specified product order nos. contain the first color of the respective color chart at the end. All other colors are available at no additional charge—simply change the color no. at the end of the product order no.



Stackable chairs with armrests on request



ASISTO faux leather
Anti-UV PP
Multi-purpose chair
Steel, chrome-plated
Black PP
EcoPELLE faux leather
440
815
450
540
580
99001-0034-820



ASISTO fabric
Anti-UV PP, seat with cover
Multi-purpose chair
Steel, chrome-plated
Black PP
Xtreme fabric (description on Seite 469)
440
815
450
540
580
99001-0035-240



ASISTO fabric
Anti-UV PP, seat with cover
Multi-purpose chair
Steel, chrome-plated
White PP
Xtreme fabric (description on Seite 469)
440
815
450
540
580
99001-0036-240

**Asisto seat upholstery (faux leather)**

■ Black	-820
---------	------

**Asisto seat upholstery (fabric)**

■ Havana, black	-240
■ Ocean, blue	-210
■ Blizzard, gray	-220
■ Scuba, navy blue	-226
■ Costa, dark blue	-230
■ Panama, red	-260
■ Padang, black gray	-270

## Fabric no.

The specified product order nos. contain the first color of the fabric chart at the end. All other colors are available at no additional charge—simply change the fabric no. at the end of the product order no.



# Bar stools

In different frame colors, with 4-foot or skid frame, optionally with seat upholstery



Model	Basic 4 Bar	Basic 4 Bar	Basic Bar
Seat	Beech, laminated	Beech, laminated	Oak, laminated
Frame	Steel, chrome-plated, stackable	Steel, chrome-plated, stackable	Steel, black
Seat shell	Beech, white	Beech, natural	Oak, veneered
Upholstered seat	-	-	-
Order no.	99001-0039-000	99001-0039-001	99001-0037-000
Price			











Basic Bar
Oak, laminated
Steel, white
Oak, veneered
-
99001-0038-001

Basic Bar
Oak, laminated with seat upholstery
Steel, black
Oak, veneered
Xtreme fabric
99001-0037-240 (Havana, black)

Basic Bar
Oak, laminated with seat upholstery
Steel, white
Oak, veneered
Xtreme fabric
99001-0038-260 (Panama, red)

## Seat upholstery fabric colors

Fabric no.

 Havana, black	-240
 Ocean, blue	-210
 Blizzard, gray	-220
 Scuba, navy blue	-226
 Costa, dark blue	-230
 Panama, red	-260
 Padang, black gray	-270

The specified product order nos. contain the specified color of the fabric chart at the end. All other colors are available at no additional charge—simply change the fabric no. at the end of the product order no.

Xtreme is a modern fabric made of up to 100% recycled polyester. This prevents waste and conserves raw materials. Thanks to its stretch characteristics, flame-resistance, long service life and anti-pilling properties, Xtreme is ideal for use on chairs.

## Composition

100% recycled flame-resistant polyester

Dyes do not contain heavy metals

Environmentally friendly

Made of 100% recycled polyester

In accordance with EU Ecolabel certificate

# Asisto

## Pull-out cabinets.

### Features of the pull-out cabinets:

- + Body in sturdy steel construction with high-quality enamel coating, fronts made of MCPB (melamine coated particle board) as standard, available in steel (double-walled and insulated)
- + Standard top cover made of MCPB (melamine coated particle board)
- + Slotted shelves in black gray on the inside
- + 1 slot-in binder support in black gray per shelf
- + Cabinet floor also slotted with 1 slot-in binder support
- + 1 open compartment with felt mat above
- + High load capacity of each shelf of 50 kg, adjustable shelves
- + Allows for quick access to personal files when pulled out, standing height cabinet provides visual and acoustic screening and acts as a central contact area for visitors
- + Metal cabinet handle, matt nickel-plated
- + Safety lock with exchangeable cylinder and 2 keys
- + Appealing design and narrow edges
- + Level adjustment as standard, incl. wide front support roll for optimal floor protection
- + Pleasant sound levels thanks to body sound absorption
- + High-quality drawer guide with soft-close



Order no. 148436-00L

On left  
Table on right



Order no. 148466-00L  
& 148436-704

### Pull-out cabinet

Width: 430 | Depth: 800  
incl. MCPB top,  
25 mm thick, for use on  
left or right next to the desk

### Standing height

On left or right,  
steel body with MCPB front wood decor

### Sitting height

On left or right,  
steel body with MCPB front wood decor

Height	1259	740
Interior fittings	Basic version with top open compartment with felt mat, 2 adjustable shelves for 3 binder heights, with 1 slot-in binder support each	Basic version with top open compartment with felt mat, 1 adjustable shelf for 1 binder height & extra compartment, with 1 slot-in binder support each
Order no. for left	148436-00L	148466-00L
Order no. for right	148436-00R	148466-00R
Price		
& optional steel front		
Order no.	+ 148436-710	+ 148466-710
& addtl. charge		
& alternative top cover as solid-core/HPL top		
Order no.	+ 148436-130	+ 148436-130
& addtl. charge		

→ Body color

Color concept → p. 48

→ Top decor

Color concept → p. 52





Pedestal on right shown here

Company

Color concept

Changing room &amp; wardrobe

Workshop &amp; factory

Office &amp; archive



### Security compartment

Interior dimensions, (H x W x D)	57 x 385 x 307/292
Order no.	148436-704
Price	



### Small part trays

Made of plastic,  
to be placed on  
the felt mat

Mini-version fits on the  
smaller surface next to the  
security compartment

Large version  
also fits in the  
security compartment

Order no.	148436-708	148436-709
Price		



### Additional binder supports

For insertion into the slotting  
of the cabinet floor and the shelves

Height x depth	185 x 340
Order no.	148436-701
Price	



# Asisto

## Mobile pedestals.

### Features of the mobile pedestals:

- + Mobile pedestal with 4 casters, front casters with lock
- + Body and drawers made of steel
- + Central locking system with 2 flap keys and exchangeable cylinder
- + Drawers and interior fittings in black
- + User-friendly, full-width handle bar on the side
- + Optimum tilt resistance thanks to counterweight and drawer with anti-tilt mechanism
- + Long-lasting and durable steel drawers:
  - 3 HU on roller guide, with 4/5 pull-out
  - 6 HU on telescopic guide, with full extension slide
- + Horizontal partitions in the middle drawers



Order no. 054530-000-165



Order no. 054510-000-102



Order no. 054230-000-165



Order no. 054210-000-102

### Dimensions and version

Width: 430

Height: 570

M = Material drawer

HU = Height units (1 HU = 50 mm)

Drawer 6 HU incl. add-on hanging frame



Depth	581	581	781	781
Drawers	M 3/6	M 3/3/3	M 3/6	M 3/3/3
Order no. RAL 9010 Pure white	054530-000-165	054510-000-165	054230-000-165	054210-000-165
Order no. RAL 9005 Deep black	054530-000-102	054510-000-102	054230-000-102	054210-000-102

Price

### Only available in the following colors:



Pure white  
RAL 9010  
Color no. -165



Deep black  
RAL 9005  
Color no. -102



Company

Color concept

Changing room & wardrobe

Workshop & factory

Office & archive

# Asisto

## Fridge caddies and caddies with trash can.

### The fridge caddies offer:

- + Excellent mobility thanks to 4 large casters (front casters with lock)
- + Steel body, double-walled, with body sound absorption for pleasant sound behavior
- + Drawers with load-bearing precision rails, all drawers fully extendable, with self-closing system and soft-stop for gentle closure
- + Drawers with versatile interior fittings
- + With cable flap above, 2 x power\* connections (up to 230 V/50 Hz), e.g. for coffee maker etc., incl. 3 meter supply line
- + Refrigerator with lock (2 keys), 62 liter volume and 3 adjustable intermediate shelves (grates)



Order no. 54780-000

### Models 54780-000 and 54780-150:

- + Drawer with cutlery compartment and small part drawer made of stainless steel
- + Drawer(s) with versatile configuration for cups and glasses
- + Drawer for storing plates and saucers

### Dimensions and versions

Incl. HPL top and intermediate shelf, 13 mm thick

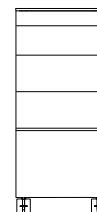
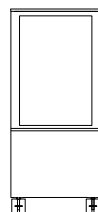

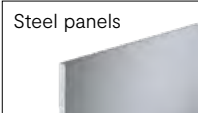
	Cabinet height: 1,157	Drawers	2, 2, 2¾ HU	6¾ HU	2, 3, 4, 4, 6¾ HU
	Cabinet width: 500	Version	With refrigerator and 3 drawers incl. interior fittings for cutlery and dishes	With refrigerator and trash can 1x18 L, 2x8 L	Top drawer empty as standard, with trash can size 1x18 L, 2x8 L and drawers for dishes (interior fittings optional)
	Cabinet depth: 600	Order no.	54780-000	54780-010	54780-150
		Price			

\*For socket strips to be used outside of Germany, please indicate the country of use (e.g. CH/Switzerland)

#### + HPL top, large

For the use of larger coffee makers, also with integrated cable flap above, 2x power connections (230 V)

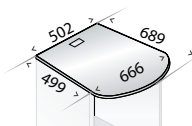

Width	502/666
Depth	499/689
& order no.	+ 5413-780
& addtl. charge	

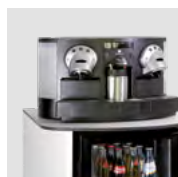

#### + Automatic opening with motion sensor

For caddy trash can, for hands-free opening, easy with a movement of the foot

For width	500
& order no.	+ 5400-760
& addtl. charge	



#### → Body color, panel/top decor and panel color

Color concept → p. 50





Order no. 54780-010



Order no. 54780-150



All caddies with integrated HPL cable flap above, connection: 2x power (230 V)



Drawer with cutlery compartment and small part drawer made of stainless steel



Drawer(s) with versatile configuration for cups and glasses



Drawer for storing plates and saucers











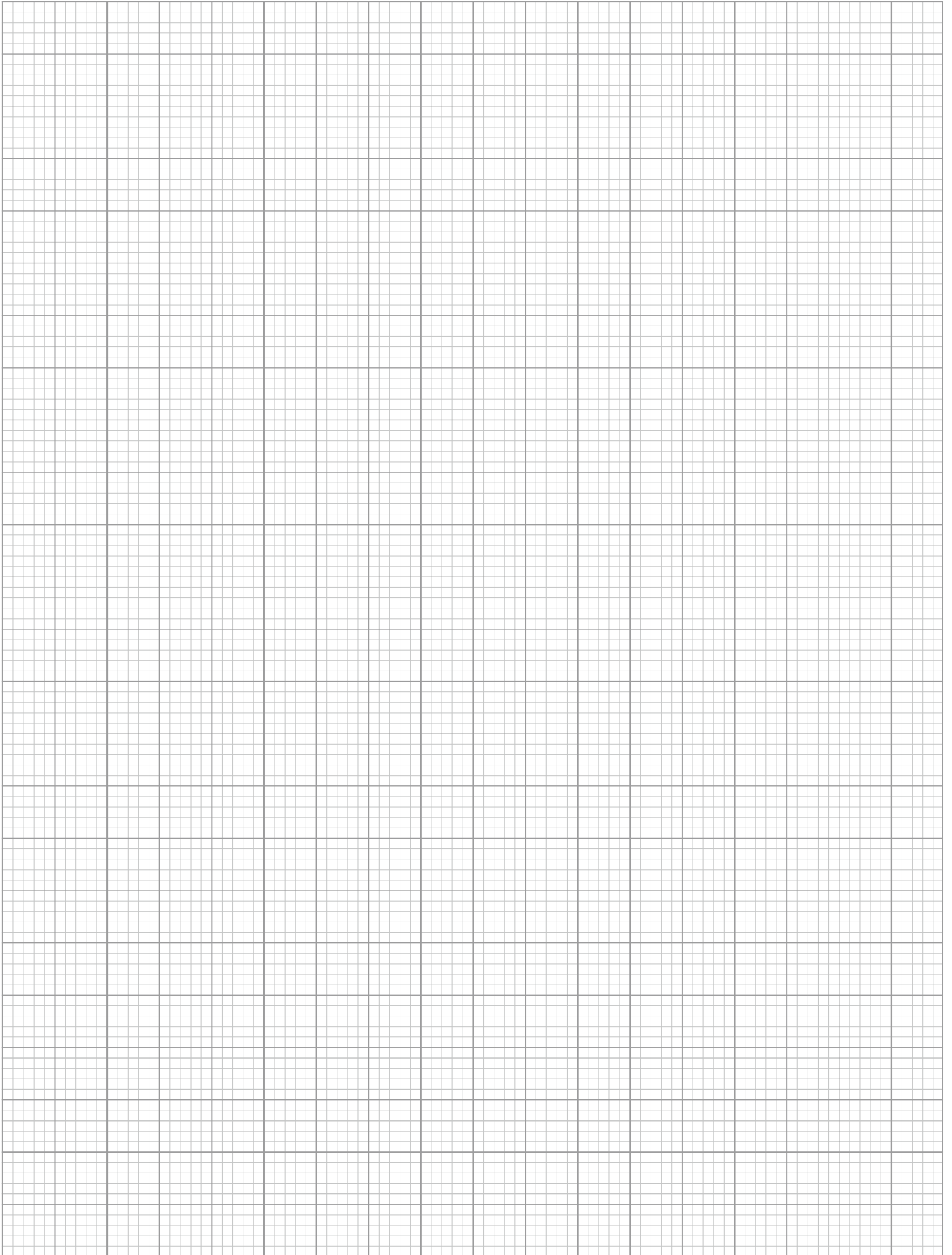



# Notes

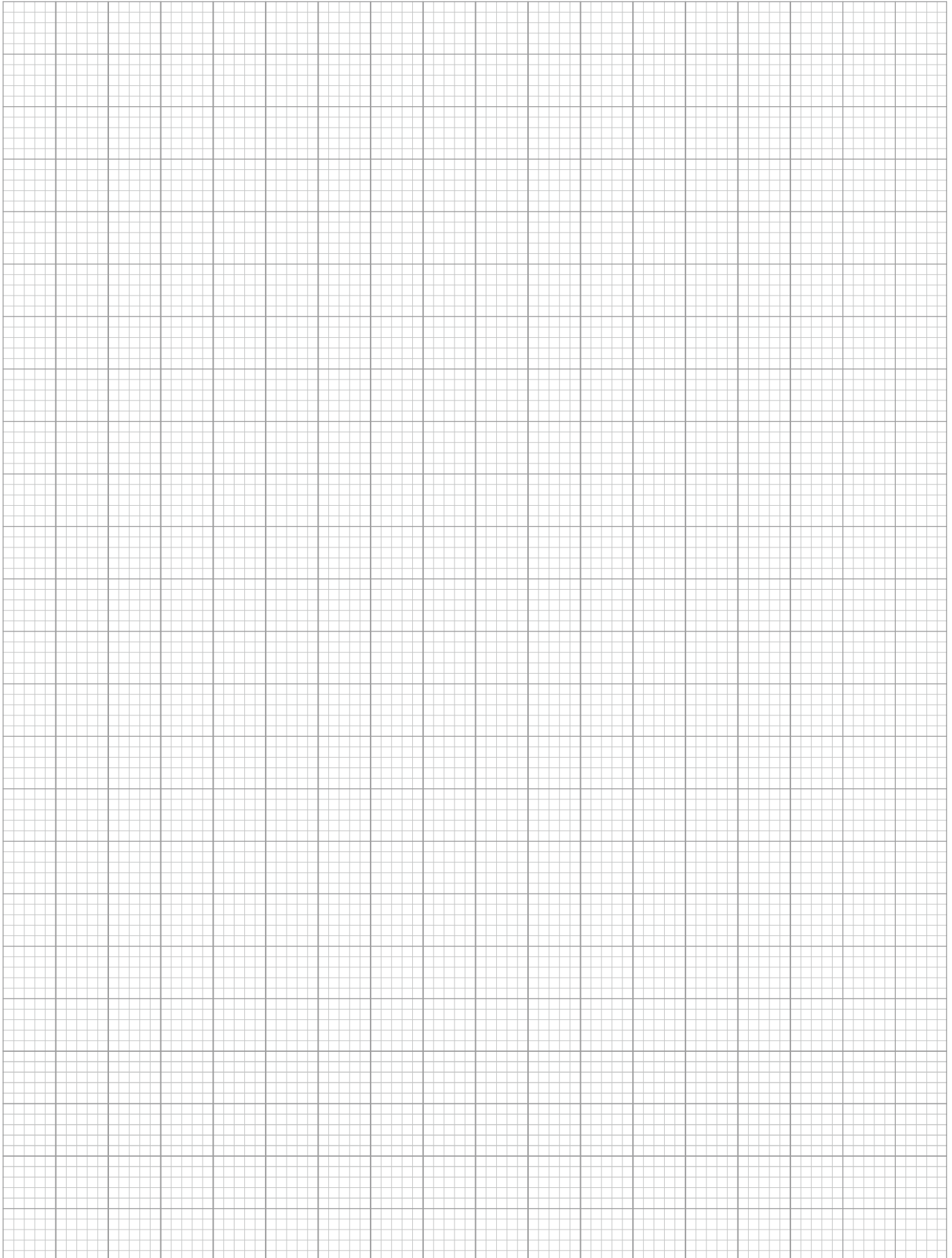

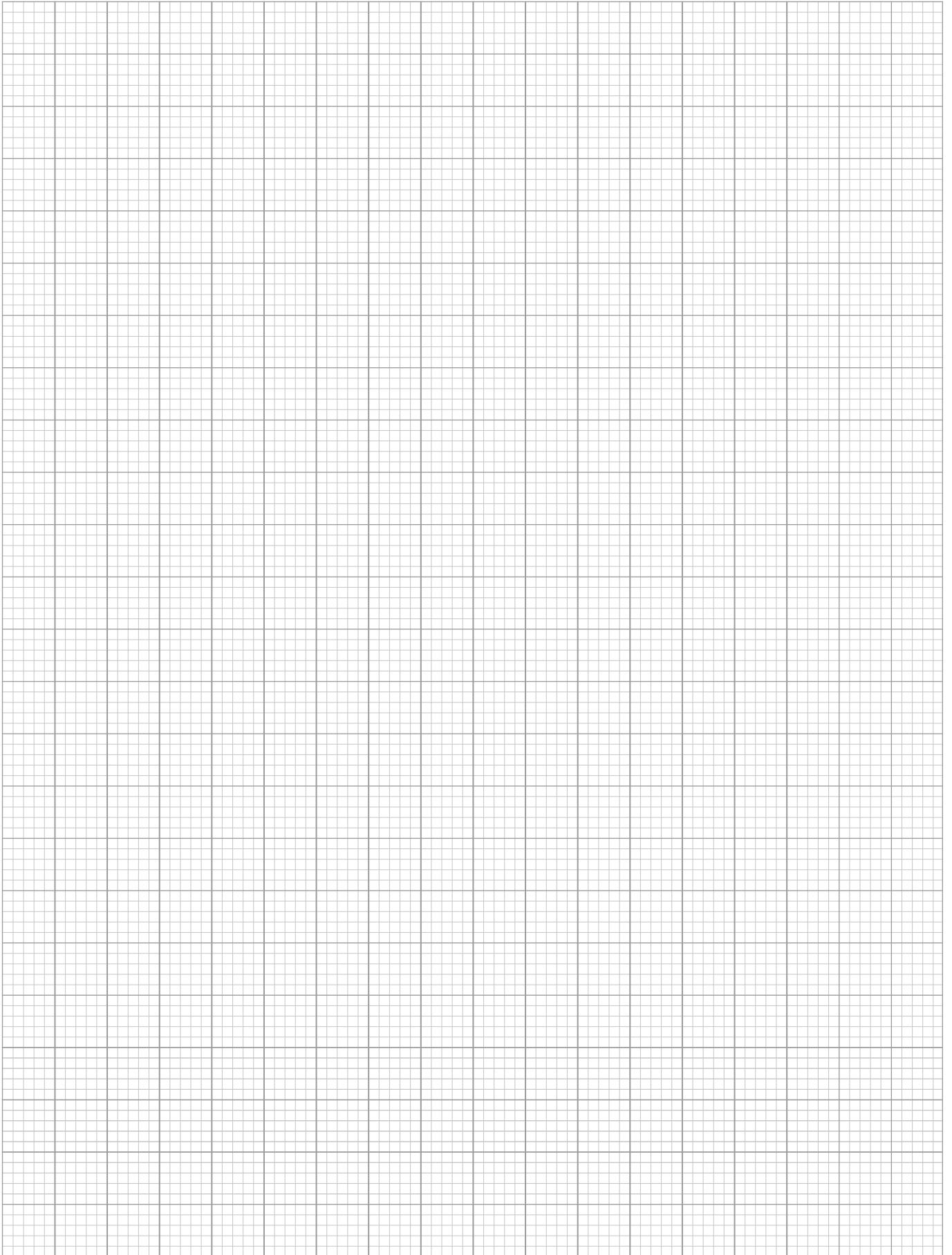

# Order number and weight register

Order no.	Weight	Page	Order no.	Weight	Page	Order no.	Weight	Page
0...			049000-106	25,30	142	049010-203	40,90	134
00002-010R		161	049000-12	24,80	101	049010-204	41,50	136
00002-14		161, 201, 213	049000-123	27,00	135	049010-205	44,20	140
00006-00		160	049000-124	26,90	137	049010-206	44,20	142
00006-21		160	049000-125	28,40	141	049010-20B	43,00	125
00008-70099R		160	049000-126	28,40	143	049010-22	43,90	101
00008-700R		160	049000-20	36,20	100	049010-223	48,40	135
00008-704R		160	049000-203	40,30	134	049010-224	48,20	137
00008-7099R		160	049000-204	40,80	136	049010-225	51,20	141
00008-70R		103, 107, 108, 122, 126, 129, 133, 160	049000-205	43,60	140	049010-226	51,20	143
00008-72R	0,010	160	049000-206	43,60	142	049010-22B	50,20	125
00010-01099R		160	049000-20B	42,40	125	049010-30	52,20	100
00010-010R		160	049000-22	43,30	101	049010-303	58,20	134
00010-012R		160	049000-223	47,80	135	049010-304	59,10	136
00010-1099R		160	049000-224	47,60	137	049010-305	63,30	140
00010-10R	0,080	160	049000-225	50,50	141	049010-306	63,30	142
00010-11		160	049000-226	50,50	143	049010-32	62,80	101
00010-12R		160	049000-22B	49,50	125	049010-323	69,50	135
00011-00		160	049000-30	51,60	100	049010-324	69,20	137
00012-00		160	049000-303	57,60	134	049010-325	73,60	141
00014-00		161	049000-304	58,50	136	049010-326	73,60	143
00018-00	0,080	95, 155, 185	049000-305	62,60	140	049010-40	67,50	101
00019-00	0,180	95, 155, 185	049000-306	62,60	142	049010-403	75,60	135
0002-10	0,200	161, 201, 213	049000-32	62,20	101	049010-404	76,70	137
0002-11	0,100	161, 201, 213	049000-323	68,90	135	049010-405	82,30	141
0003-00	0,100	201, 213, 240	049000-324	68,60	137	049010-406	82,30	143
0004-11		273, 283, 373	049000-325	73,00	141	0490105-10	93,30	204
0005-00		437	049000-326	73,00	143	0490105-20	96,60	204
0005-10		273, 283, 395, 418, 430	049000-40	66,90	101	0490105-30	99,80	204
0006-00		213, 240	049000-403	75,00	135	0490105-40	103,10	204
0006-21		201, 213	049000-404	76,10	137	049012-20	33,40	114
0006-50		273, 373	049000-405	81,70	141	049012-20B	40,30	125
0010-11		213, 240	049000-406	81,70	143	049012-22	43,90	114
0011-00		201, 213, 240	0490005-10	92,70	204	049012-22B	50,40	125
0012-00		201, 213, 240	0490005-20	96,00	204	049012-40	60,70	114
0102-00	0,040	436	0490005-30	99,20	204	049013-102	97,90	146
0104-00	0,120	436	0490005-40	102,40	204	049013-122	99,90	147
0108-00	0,200	436	049002-20	32,80	114	049013-204	105,80	146
0202-00	0,060	436	049002-20B	39,70	125	049013-224	109,60	147
0204-00	0,140	436	049002-22	43,30	114	049013-306	113,60	146
0208-00	0,260	436	049002-22B	49,80	125	049013-326	119,40	147
0216-00	0,420	436	049002-40	60,00	114	049013-408	121,40	147
04900-131		155	049003-102	97,30	146	04902-0601		157
04900-132		155	049003-122	99,30	147	04902-0611		157
04900-133		155	049003-204	105,10	146	049020-10	21,50	100
04900-134		155	049003-224	109,00	147	049020-103	24,00	134
04900-141		155	049003-306	113,00	146	049020-104	24,30	136
04900-142		155	049003-326	118,80	147	049020-105	25,70	140
04900-4920		156	049003-408	120,80	147	049020-106	25,70	142
04900-705	1,66	95, 155	04901-0601	0,050	157	049020-12	25,40	101
04900-7061		156	04901-0611	0,030	157	049020-123	27,60	135
04900-715		156	04901-303		154	049020-124	27,50	137
04900-742		97, 157	04901-303D		154	049020-125	29,00	141
04900-744		97, 157	04901-306		155	049020-126	29,00	143
04900-770	0,110	95, 156	04901-308		154	049020-20	37,20	100
04900-7703	0,120	156	04901-308D		154	049020-203	41,30	134
04900-772	0,150	95, 156	049010-10	22,20	100	049020-204	41,80	136
04900-7723	0,120	156	049010-103	24,20	134	049020-205	44,60	140
04900-7733		156	049010-104	24,50	136	049020-206	44,60	142
049000-10	21,60	100	049010-105	25,90	140	049020-20B	43,40	125
049000-103	23,60	134	049010-106	25,90	142	049020-22	44,60	101
049000-104	23,90	136	049010-12	25,40	101	049020-223	49,10	135
049000-105	25,30	140	049010-123	27,60	135	049020-224	48,90	137
			049010-124	27,50	137	049020-225	51,80	141
			049010-125	29,00	141	049020-226	51,80	143
			049010-126	29,00	143	049020-22B	50,80	125
			049010-20	36,90	100	049020-30	53,20	100

Order no.	Weight	Page
049020-303	59,10	134
049020-304	60,00	136
049020-305	64,20	140
049020-306	64,20	142
049020-32	64,40	101
049020-323	71,10	135
049020-324	70,80	137
049020-325	75,20	141
049020-326	75,20	143
049020-40	69,10	101
049020-403	77,10	135
049020-404	78,30	137
049020-405	83,80	141
049020-406	83,80	143
0490205-10	93,10	204
0490205-20	97,00	204
0490205-30	100,80	204
0490205-40	104,60	204
049022-20	33,80	114
049022-20B	40,70	125
049022-22	44,50	114
049022-22B	51,10	125
049022-40	62,20	114
049023-102	97,70	146
049023-122	99,90	147
049023-204	106,10	146
049023-224	110,30	147
049023-306	114,60	146
049023-326	120,90	147
049023-408	123,00	147
0490307-10	24,00	102
0490307-12	27,70	103
0490307-20	39,70	102
0490307-22	47,00	103
0490307-30	52,90	102
0490307-32	64,90	103
0490307-40	67,70	103
0490327-20	44,90	116
0490327-22	48,30	116
0490327-40	77,90	116
0490337-102	100,40	148
0490337-122	102,50	149
0490337-204	109,60	148
0490337-224	58,20	149
0490337-306	115,50	148
0490337-326	121,90	149
0490337-408	78,20	149
049040-10	25,90	108
049040-10 + 08510-004		110
049040-12	30,90	109
049040-12 + 08512-004		111
049040-20	41,30	108
049040-20 + 08520-004		110
049040-22	49,30	109
049040-22 + 08522-004		111
049040-30	57,10	108
049040-30 + 08530-004		110
049040-32	70,30	109
049040-32 + 08532-004		111
049040-40	73,10	109
049040-40 + 08540-004		111
0490407-10	27,10	102
0490407-10 + 08510		104
0490407-10 + 08510-004		106
0490407-12	29,90	103
0490407-12 + 08512		105

Order no.	Weight	Page
0490407-12 + 08512-004		107
0490407-20	41,20	102
0490407-20 + 08520		104
0490407-20 + 08520-004		106
0490407-22	49,90	103
0490407-22 + 08522		105
0490407-22 + 08522-004		107
0490407-30	56,10	102
0490407-30 + 08530		104
0490407-30 + 08530-004		106
0490407-32	68,00	103
0490407-32 + 08532		105
0490407-32 + 08532-004		107
0490407-40	70,70	103
0490407-40 + 08540		105
0490407-40 + 08540-004		107
049042-20	46,40	122
049042-20 + 08520-004		123
049042-22	50,60	122
049042-22 + 08522-004		123
049042-40	83,30	122
049042-40 + 08540-004		123
0490427-20	46,30	116
0490427-20 + 08520		118
0490427-20 + 08520-004		120
0490427-22	51,20	116
0490427-22 + 08522		118
0490427-22 + 08522-004		120
0490427-40	81,00	116
0490427-40 + 08540		118
0490427-40 + 08540-004		120
0490437-102	103,50	148
0490437-102 + 08510		150
0490437-102 + 08510-004		152
0490437-122	104,80	149
0490437-122 + 08512		151
0490437-122 + 08512-004		153
0490437-204	111,00	148
0490437-204 + 08520		150
0490437-204 + 08520-004		152
0490437-224	61,10	149
0490437-224 + 08522		151
0490437-224 + 08522-004		153
0490437-306	118,60	148
0490437-306 + 08530		150
0490437-306 + 08530-004		152
0490437-326	124,90	149
0490437-326 + 08532		151
0490437-408	81,30	149
0490437-408 + 08540		151
0490437-408 + 08540-004		153
0490507-10	25,90	102
0490507-10 + 08510		104
0490507-10 + 08510-004		106
0490507-12	30,90	103
0490507-12 + 08512		105
0490507-12 + 08512-004		107
0490507-20	41,30	102
0490507-20 + 08520		104
0490507-20 + 08520-004		106
0490507-22	49,30	103
0490507-22 + 08522		105
0490507-22 + 08522-004		107
0490507-30	57,10	102
0490507-30 + 08530		104
0490507-30 + 08530-004		106
0490507-32	70,30	103

Order no.	Weight	Page
0490507-32 + 08532		105
0490507-32 + 08532-004		107
0490507-40	73,10	103
0490507-40 + 08540		105
0490507-40 + 08540-004		107
0490527-20	46,40	116
0490527-20 + 08520		118
0490527-20 + 08520-004		120
0490527-22	50,60	116
0490527-22 + 08522		118
0490527-22 + 08522-004		120
0490527-40	83,30	116
0490527-40 + 08540		118
0490527-40 + 08540-004		120
0490537-102	102,20	148
0490537-102 + 08510		150
0490537-102 + 08510-004		152
0490537-122	105,70	149
0490537-122 + 08512		151
0490537-122 + 08512-004		153
0490537-204	111,10	148
0490537-204 + 08520		150
0490537-204 + 08520-004		152
0490537-224	60,50	149
0490537-224 + 08522		151
0490537-224 + 08522-004		153
0490537-306	119,70	148
0490537-306 + 08530		150
0490537-306 + 08530-004		152
0490537-326	127,20	149
0490537-326 + 08532		151
0490537-326 + 08532-004		153
0490537-408	83,60	149
0490537-408 + 08540		151
0490537-408 + 08540-004		153
049090-10	86,99	144
049090-12	86,99	145
049090-20	87,09	144
049090-22	87,09	145
049090-30	87,20	144
049090-32	87,20	145
049090-40	87,30	145
0490910-730		144
0490912-730		145
049092-20	86,99	144
049092-22	86,99	144
049092-40	87,10	144
0490920-730		144
0490922-730		144, 145
0490930-730		144
0490932-730		145
0490940-730		144, 145
049100-00	32,80	124
049100-02	43,30	124
049110-00	33,40	124
049110-02	43,90	124
049110-730		100, 102, 104, 106, 108, 110
049110-750		100, 102, 104, 106, 108, 110
049112-730		101, 103, 105, 107, 109, 111
049112-750		101, 103, 105, 107, 109, 111
049120-00	33,80	124



# Order number and weight register

Order no.	Weight	Page	Order no.	Weight	Page	Order no.	Weight	Page
049120-02	44,60	124	049232-750		126, 128, 130, 132	0493407-30 + 08530		130
049120-730		100, 102, 104, 106, 108, 110, 114, 116, 118, 120, 122, 123, 124, 125	049240-730		126, 128, 130, 132, 147, 149, 151, 153	0493407-30 + 08530-004	72,70	132
049120-750		100, 102, 104, 106, 108, 110, 114, 116, 118, 120, 122, 123, 124, 125	049240-750		126, 128, 130, 132	0493407-32		128
049122-730		101, 103, 105, 107, 109, 111, 114, 116, 118, 120, 122, 123, 124, 125	049300-10	18,60	126	0493407-32 + 08532		130
049122-750		101, 103, 105, 107, 109, 111, 114, 116, 118, 120, 122, 123, 124, 125	049300-12	24,00	126	0493407-32 + 08532-004		132
049130-730		100, 102, 104, 106, 108, 110	049300-20	30,40	126	0493407-40	71,40	128
049130-750		100, 102, 104, 106, 108, 110	049300-22	41,80	126	0493407-40 + 08540		130
049132-730		101, 103, 105, 107, 109, 111	049300-30	42,80	126	0493407-40 + 08540-004		132
049132-750		101, 103, 105, 107, 109, 111	049300-32	59,90	126	0493507-10	98,90	128
049140-730		101, 103, 105, 107, 109, 111, 114, 116, 118, 120, 122, 123	049300-40	55,20	126	0493507-10 + 08510		130
049140-750		101, 103, 105, 107, 109, 111, 114, 116, 118, 120, 122, 123	0493005-10	93,40	205	0493507-10 + 08510-004		132
049210-730		126, 128, 130, 132, 146, 148, 150, 152	0493005-20	97,20	205	0493507-12	32,80	128
049210-750		126, 128, 130, 132	0493005-30	101,10	205	0493507-12 + 08512		130
049212-730		126, 128, 130, 132, 147, 149, 151, 153	0493005-40	104,90	205	0493507-12 + 08512-004		132
049212-750		126, 128, 130, 132	049310-10	19,30	126	0493507-20	41,60	128
049220-730		126, 128, 130, 132, 146, 148, 150, 152	049310-12	24,60	126	0493507-20 + 08520		130
049220-750		126, 128, 130, 132	049310-20	31,00	126	0493507-20 + 08520-004		132
049222-730		126, 128, 130, 132, 147, 149, 151, 153	049310-22	42,40	126	0493507-22	52,40	128
049230-730		126, 128, 130, 132, 146, 148, 150, 152	049310-30	43,40	126	0493507-22 + 08522		130
049230-750		126, 128, 130, 132	049310-32	60,50	126	0493507-22 + 08522-004		132
049232-730		126, 128, 129, 130, 132, 147, 149, 151, 153	049310-40		126	0493507-30	57,60	128
			049310-730		134	0493507-30 + 08530		130
			0493105-10	94,00	205	0493507-30 + 08530-004		132
			0493105-20	97,80	205	0493507-32	75,00	128
			0493105-30	101,70	205	0493507-32 + 08532		130
			0493105-40	105,60	205	0493507-32 + 08532-004		132
			049312-730		135	0493507-40	73,70	128
			049320-10	18,60	126	0493507-40 + 08540		130
			049320-12	24,50	126	0493507-40 + 08540-004		132
			049320-20	31,30	126	049410-730		136
			049320-22	43,10	126	049412-730		137
			049320-30	44,30	126	049420-730		136
			049320-32	61,90	126	049422-730		137
			049320-40	55,20	126	049430-730		136
			049320-730		134	049432-730		137
			0493205-10	93,80	205	049440-730		137
			0493205-20	98,20	205	049510-730		140
			0493205-30	102,70	205	049512-730		141
			0493205-40	107,10	205	049520-730		140
			049322-730		135	049522-730		141
			049330-730		134	049530-730		140
			0493307-10	97,10	128	049532-730		141
			0493307-12	29,70	128	049540-730		141
			0493307-20	40,10	128	049600-20	35,90	124
			0493307-22	50,20	128	049600-22	46,20	124
			0493307-30	53,40	128	049610-20	36,50	124
			0493307-32	69,60	128	049610-22	46,80	124
			0493307-40	68,40	128	049610-730		142
			049332-730		135	049612-730		143
			049340-730		135	049620-20	36,80	124
			0493407-10	100,20	128	049620-22	47,40	124
			0493407-10 + 08510		130	049620-730		142
			0493407-10 + 08510-004		132	049622-730		143
			0493407-12	31,90	128	049630-730		142
			0493407-12 + 08512		130	049632-730		143
			0493407-12 + 08512-004		132	049640-730		143
			0493407-20	41,50	128	054210-000-165		472
			0493407-20 + 08520		130	054230-000-165		472
			0493407-20 + 08520-004		132	054510-000-165		472
			0493407-22	53,10	128	054530-000-165		472
			0493407-22 + 08522		130	054210-000-165		472
			0493407-22 + 08522-004		132	054230-000-165		472
			0493407-30	56,60	128	054510-000-165		472
						054530-000-165		472
						08000-061	0,130	95, 155
						08000-201		94, 154
						08000-202		94, 154

Order no.	Weight	Page
08000-203		94, 154
08000-204		94, 154
08000-211		94, 154
08000-212		94, 154
08000-213		94, 154
08000-214		94, 154
08000-26		96
08000-261		96
08000-34030		94, 154
08000-34040		94, 154
08000-34060		94, 154
08000-34080		94, 154
08000-34090		94, 154
08000-34120		94, 154
08000-7072	0,230	96, 156
08000-7073	0,290	96, 156
08000-80	1,45	96, 156
08000-8020		96
08000-80200		156
08000-80250		96, 156
08000-80300		156
08000-80350		156
080000-10	21,80	62
080000-103	22,30	80
080000-104	23,50	82
080000-105	24,80	84
080000-12	24,80	62
080000-123	25,60	81
080000-124	27,10	83
080000-125	28,50	85
080000-12F	24,80	64
080000-19	21,80	256
080000-20	35,40	62
080000-203	36,80	80
080000-204	39,10	82
080000-205	41,50	84
080000-20B	35,40	75
080000-22	41,20	62
080000-223	43,50	81
080000-224	46,30	83
080000-225	49,10	85
080000-22B	41,20	75
080000-22F	41,20	64
080000-29	35,40	256
080000-30	49,20	62
080000-303	51,40	80
080000-304	54,80	82
080000-305	58,20	84
080000-32	59,30	62
080000-323	63,00	81
080000-324	67,20	83
080000-325	71,30	85
080000-32F	59,30	64
080000-39	49,20	256
080000-40	63,80	62
080000-403	67,00	81
080000-404	71,50	83
080000-405	76,00	85
080000-49	63,80	256
080002-20	35,50	70
080002-20B	35,50	75
080002-22	41,30	70
080002-22B	41,30	75
080002-40	63,90	70
080003-102	22,50	88
080003-122	25,80	89
080003-204	36,60	88
080003-224	42,80	89
080003-306	50,90	88
080003-326	62,10	89
080003-408	66,70	89
080002-80	1,91	96, 156
080002-80200		156
080002-80250		96, 156
080002-80300		156
080002-80350		156
080020-10	22,50	62
080020-103	23,00	80
080020-104	24,10	82
080020-105	25,30	84
080020-12	25,80	63

Order no.	Weight	Page
080003-224	42,80	89
080003-306	50,90	88
080003-326	62,10	89
080003-408	66,70	89
08001-303		94
08001-303D		94
08001-308		94
08001-308D		94
080010-10	21,80	62
080010-103	22,30	80
080010-104	23,50	82
080010-105	24,80	84
080010-12	24,80	63
080010-123	25,60	81
080010-124	27,10	83
080010-125	28,50	85
080010-12F	24,80	64
080010-19	21,80	256
080010-20	35,40	62
080010-203	36,80	80
080010-204	39,10	82
080010-205	41,50	84
080010-20B	42,80	75
080010-22	41,20	63
080010-223	43,50	81
080010-224	46,30	83
080010-225	49,10	85
080010-22B	50,40	75
080010-22F	41,20	64
080010-29	36,60	256
080010-30	49,20	62
080010-303	51,40	80
080010-304	54,80	82
080010-305	58,20	84
080010-32	59,30	63
080010-323	63,00	81
080010-324	67,20	83
080010-325	71,30	85
080010-32F	59,30	64
080010-39	60,30	256
080010-40	63,80	63
080010-403	67,00	81
080010-404	71,50	83
080010-405	76,00	85
080010-49	74,50	256
080012-20	35,50	70
080012-20B	42,90	75
080012-22	41,30	70
080012-22B	50,10	75
080012-40	63,90	70
080013-102	22,50	88
080013-122	25,80	89
080013-204	36,60	88
080013-224	42,80	89
080013-306	50,90	88
080013-326	62,10	89
080013-408	66,70	89
08002-80	1,91	96, 156
08002-80200		156
08002-80250		96, 156
08002-80300		156
08002-80350		156
080020-10	22,50	62
080020-103	23,00	80
080020-104	24,10	82
080020-105	25,30	84
080020-12	25,80	63

Order no.	Weight	Page
080020-123	26,50	81
080020-124	27,90	83
080020-125	29,60	85
080020-12F	25,80	64
080020-19	22,50	256
080020-20	36,60	62
080020-203	37,80	80
080020-204	40,00	82
080020-205	42,30	84
080020-20B	44,00	75
080020-22	42,80	63
080020-223	44,80	81
080020-224	47,70	83
080020-225	50,50	85
080020-22B	51,80	75
080020-22F	42,80	64
080020-29	36,60	256
080020-30	50,90	62
080020-303	53,20	80
080020-304	54,60	82
080020-305	59,80	84
080020-32	62,10	63
080020-323	65,50	81
080020-324	69,70	83
080020-325	73,80	85
080020-32F	62,10	64
080020-39	50,90	256
080020-40	66,70	63
080020-403	69,50	81
080020-404	74,00	83
080020-405	78,40	85
080020-49	66,70	256
080022-20	36,40	70
080022-20B	43,80	75
080022-22	42,70	70
080022-22B	51,50	75
080022-40	66,60	70
080023-102	22,50	88
080023-122	25,80	89
080023-204	36,60	88
080023-224	42,80	89
080023-306	50,90	88
080023-326	62,10	89
080023-408	66,70	89
0800307-10	30,70	66
0800307-12	25,50	67
0800307-20	40,50	66
0800307-22	48,60	67
0800307-30	57,20	66
0800307-32	70,10	67
0800307-40	72,00	67
0800327-20	40,50	70
0800327-22	49,00	70
0800327-40	72,10	70
0800337-102	30,70	90
0800337-122	25,50	91
0800337-204	40,50	90
0800337-224	49,00	91
0800337-306	57,20	90
0800337-326	70,10	91
0800337-408	72,10	91
0800407-10	30,70	66
0800407-10 + 08510		68
0800407-12	25,50	67
0800407-12 + 08512		69
0800407-20	40,50	66
0800407-20 + 08520		68

# Order number and weight register

Order no.	Weight	Page	Order no.	Weight	Page	Order no.	Weight	Page
0800407-22	48,60	67	080090-20	88,87	86	0803407-40 + 08540		78
0800407-22 + 08522		69	080090-22	59,58	87	0803507-10	30,50	77
0800407-30	57,20	66	080090-30	59,70	86	0803507-10 + 08510		78
0800407-30 + 08530		68	080090-32	91,24	87	0803507-12	25,50	77
0800407-32	70,10	67	080090-40	59,82	87	0803507-12 + 08512		78
0800407-32 + 08532		69	080092-20	59,46	86	0803507-20	41,10	77
0800407-40	72,00	67	080092-22	59,46	86	0803507-20 + 08520		78
0800407-40 + 08540		69	080092-40	91,57	86	0803507-22	48,90	77
0800427-20	40,50	71	080100-00	36,10	74	0803507-22 + 08522		78
0800427-20 + 08520		72	080100-02	40,90	74	0803507-30	58,10	77
0800427-22	49,00	71	080110-00	36,10	74	0803507-30 + 08530		78
0800427-22 + 08522		72	080110-02	40,90	74	0803507-32	70,60	77
0800427-40	72,10	71	080120-00	37,10	74	0803507-32 + 08532		78
0800427-40 + 08540		72	080120-02	44,20	74	0803507-40	73,40	77
0800437-102	30,70	90	080300-10	21,60	76	0803507-40 + 08540		78
0800437-102 + 08510		92	080300-12	24,80	76	08050-70110	1,14	66, 68, 77, 78, 90, 92, 102, 104, 106, 128, 130, 132, 148, 150, 152
0800437-122	25,50	91	080300-19	21,60	257			
0800437-122 + 08512		93	080300-20	35,90	76			
0800437-204	40,50	90	080300-22	41,50	76			
0800437-204 + 08520		92	080300-29	35,90	257			
0800437-224	49,00	91	080300-30	49,90	76	08050-70112	1,36	67, 69, 77, 78, 91, 93, 103, 105, 107, 128, 130, 132, 149, 151, 153
0800437-224 + 08522		93	080300-32	60,10	76			
0800437-306	57,20	90	080300-39	49,90	257			
0800437-306 + 08530		92	080300-40	65,00	76			
0800437-326	70,10	91	080300-49	65,00	257			
0800437-326 + 08532		93	080310-10	21,60	76	08050-70120	1,81	66, 68, 70, 71, 72, 77, 78, 90, 92, 102, 104, 106, 117, 118, 120, 128, 130, 132, 148, 150, 152
0800437-408	72,10	91	080310-12	24,80	76			
0800437-408 + 08540		93	080310-19	21,60	257			
0800507-10	30,70	66	080310-20	35,90	76			
0800507-10 + 08510		68	080310-22	41,50	76			
0800507-12	25,50	67	080310-29	35,90	257			
0800507-12 + 08512		69	080310-30	49,90	76	08050-70122	14,25	67, 69, 70, 71, 72, 77, 78, 91, 93, 103, 105, 107, 118, 120, 128, 130, 132, 149, 151, 153
0800507-12F	25,50	65	080310-32	60,10	76			
0800507-20	40,50	66	080310-39	49,90	257			
0800507-20 + 08520		68	080310-40	65,00	76			
0800507-22	48,60	67	080310-49	65,00	257			
0800507-22 + 08522		69	080320-10	22,10	76			
0800507-22F	48,60	65	080320-12	25,70	76	08050-70130	2,49	66, 68, 77, 78, 90, 92, 102, 103, 104, 106, 107, 128, 129, 130, 132, 148, 150, 152
0800507-30	57,20	66	080320-19	22,10	257			
0800507-30 + 08530		68	080320-20	37,10	76			
0800507-32	70,10	67	080320-22	42,90	76			
0800507-32 + 08532		69	080320-29	37,10	257			
0800507-32F	70,10	65	080320-30	51,80	76			
0800507-40	72,00	67	080320-32	62,90	76	08050-70132	15,15	67, 69, 77, 78, 91, 93, 103, 105, 107, 128, 129, 130, 132, 133, 149, 151, 153
0800507-40 + 08540		69	080320-39	51,80	257			
0800527-20	40,50	71	080320-40	68,00	76			
0800527-20 + 08520		72	080320-49	68,00	257			
0800527-22	49,00	71	0803307-10	30,50	77	08050-70140	15,15	67, 69, 70, 71, 72, 77, 78, 91, 93, 103, 105, 107, 118, 119, 120, 128, 130, 132, 149, 151, 153
0800527-22 + 08522		72	0803307-12	25,50	77			
0800527-40	72,10	71	0803307-20	41,10	77			
0800527-40 + 08540		72	0803307-22	48,90	77			
0800537-102	30,70	90	0803307-30	58,10	77			
0800537-102 + 08510		92	0803307-32	70,60	77			
0800537-122	25,50	91	0803307-40	73,40	77			
0800537-122 + 08512		93	0803407-10	30,50	77			
0800537-204	40,50	90	0803407-10 + 08510		78			
0800537-204 + 08520		92	0803407-12	25,50	77			
0800537-224	49,00	91	0803407-12 + 08512		78			
0800537-224 + 08522		93	0803407-20	41,10	77			
0800537-306	57,20	90	0803407-20 + 08520		78			
0800537-306 + 08530		92	0803407-22	48,90	77			
0800537-326	70,10	91	0803407-22 + 08522		78			
0800537-326 + 08532		93	0803407-30	58,10	77			
0800537-408	72,10	91	0803407-30 + 08530		78			
0800537-408 + 08540		93	0803407-32	70,60	77			
080090-10	59,46	86	0803407-32 + 08532		78			
080090-12	59,46	87	0803407-40	73,40	77			

Order no.	Weight	Page
08500-731RKR	0,040	164
08500-738		162
08500-741		162
08500-7450		165
08500-745R		165
08500-764SR	0,010	162
08500-766	0,050	162
08500-765SR	0,010	162
08500-767R	0,010	162
08500-768R		162
08500-7721R	0,420	103, 129
08500-7722R	0,420	163
08500-7732R	0,420	140
08500-774		163
08500-7821R	0,030	105, 108, 131, 133, 134, 141, 142, 149, 163
08500-7831R	0,030	133
08500-784		163
08500-7871R	0,420	162
08500-789	0,240	162, 252
08500-7930R		162
08500-7931R		162
08500-7940R		100, 107, 108, 126, 136, 147
08500-797R	0,030	153, 162
08500-798R		162
08501-06	0,020	97, 157
08501-0611	0,050	97
08501-071		95, 155
08501-40R		164
08501-40RKH	0,040	164
08501-40RKR	0,040	164
08501-4101		164
08501-4101KH	0,050	164
08501-4101KR	0,050	164
08501-4102		164
08501-4102KH	0,010	164
08501-4102KR	0,010	164
08501-430		164
08501-4651	0,010	165
08501-4651KH	0,010	165
08501-47	0,010	165
08501-48	0,010	165
08501-55	0,010	164
08502-0611		97
08504-10	2,70	94, 154
08504-12	3,00	94, 154
08504-20	3,60	94, 154
08504-22	4,30	94, 154
08504-30	4,80	94, 154
08504-32	6,60	94, 154
08504-40	6,60	94, 154
08505-02		95
08511-00		164
08511-20		165
08511-21		165
08511-22		165
1000-53	0,280	391
1000-841	0,130	372
1000-842	0,190	372
1034-80	1,87	360, 362
1035-80	2,29	360, 362
1036-80	2,54	360, 362
1037-80	3,12	360, 362
1040-38	1,48	365, 372

Order no.	Weight	Page
1040-49	3,13	372
1040-80	2,93	361, 363, 364, 369
1040-811	9,59	372
1040-82	2,36	373
1040-83	2,28	373
1050-38	1,86	365, 372
1050-80	3,46	279, 361, 363, 364, 369
1050-811	10,48	372
1050-82	2,55	373
1050-83	2,47	373
1051-80	4,16	361, 363, 369
1060-80	5,21	361, 363, 369
1060-811	9,52	372
1060-82	2,96	373
1060-83	2,99	373
1061-80	6,18	361, 369
1118-00-20	0,100	372, 395
1124-110	4,57	370
1125-110	5,14	370
1128-3399		384
1131-02	0,730	384
1160-000	69,70	382
1160-80	2,66	382
1161-000	102,76	382
1170-00	113,41	383
1170-100	132,34	383
1170-200	125,46	383
1170-701	0,340	384
1170-80	3,12	382, 383
1170-8110	4,64	384
1170-82	2,55	384
1170-83	2,57	384
1171-00	89,08	382
1180-00	143,34	383
1180-80	4,01	382, 383
1180-8110	5,03	384
1180-82	2,88	384
1180-83	2,76	384
1181-00	105,05	382
12412-311	30,01	416
12423-311	48,19	416
12423-321	43,97	417
12434-311	50,31	416
12434-321	65,90	417
12736-322	80,12	417
12912-312	52,70	416
12923-312	77,58	416
12923-322	70,27	417
12934-312	74,73	416
12934-322	88,98	417
12936-323	116,79	417
130013-81	1,57	307
130044-81	3,52	307
130076-5713	2,80	310
130276-61	198,85	310
130276-613	147,16	311
130276-62	197,10	310
130276-63	231,15	310
130276-64	235,87	310
130276-65	173,49	310
130276-66	180,92	310
130276-67	194,96	310
130276-68	196,61	310
133113-20	51,51	308
133113-21	69,49	308

Order no.	Weight	Page
133113-22	75,56	308
133113-23	79,27	308
133144-20	62,01	309
133144-22	91,16	308
133144-23	99,71	309
133144-24	103,17	309
133144-25	98,01	309
133144-27	100,69	309
133144-28	114,93	309
133144-29	112,31	309
133413-20	42,23	307
133413-210	100,62	307
133413-22	59,31	306
133413-23	62,50	306
133413-24	105,77	306
133413-25	66,25	307
133413-27	82,78	306
133413-28	59,31	306
133413-29	67,84	307
133944-21	36,35	306
133944-22	52,66	306
133944-23	54,18	306
133944-24	58,26	306
133944-25	59,54	306
133944-701	1,50	307
134013-02	21,90	274
134013-20	27,37	305
134013-21	32,39	305
134013-22	22,65	274, 305
134013-23	27,81	305
134013-24	31,14	305
134013-701	1,75	307
140000-701	1,20	381, 398, 412
140001-000	62,28	379
140001-110		380, 398, 412
140001-130	11,70	380, 398, 412, 430
140001-580	6,68	380
140001-80	2,92	380, 398
140001-811	3,29	381
140002-000	67,87	379
140002-110		380, 398, 412
140002-130	9,10	380, 398, 412
140002-580	5,58	380
140002-80	4,77	380, 398
140002-811	2,92	381
140003-000	51,57	379
140003-110		380, 412
140003-130	7,28	380, 412, 430
140003-580	4,39	380
140003-80	2,92	380
140003-811	2,73	381
140003-88	3,22	381
140011-000	121,02	379
140012-000	107,71	379
140013-000	43,92	379
140031-000	52,01	378
140032-000	48,12	378
140033-000	40,48	378
140052-000	93,33	378
140053-000	80,55	378
141000-701	7,42	377, 398
141001-000	104,88	376
141001-710		376
141001-750		376
141002-000	94,66	376
141002-710		376



# Order number and weight register

Order no.	Weight	Page	Order no.	Weight	Page	Order no.	Weight	Page
141002-750		376	143032-000	58,39	411	2017-000	74,29	317, 390
141003-000	79,05	376	143033-000	63,74	411	2017-110	7,40	370
141003-710		376	143051-000	54,99	410	2018-000	9,83	317, 391
141003-750		376	143051-716		410	2019-000	16,56	317, 391
141010-701	6,83	377, 398	143052-000	49,57	410	2025-02	0,030	418, 430
141011-000	92,17	376	143053-000	39,73	410	2025-021	0,030	395
141011-710		376	146000-703		431	2025-026		395
141011-750		376	146000-704		431	2025-03	0,030	395
141012-000	80,60	376	146000-705		431	2025-031		395
141012-710		376	146000-706	1,35	430	2026-00	3,83	393
141012-750		376	146000-707	0,130	430	2027-00	4,81	267, 363, 371, 393, 395
141013-000	66,70	376	146000-740	0,500	430	2028-00	5,07	267, 363, 371, 395
141013-710		376	146000-750	0,500	430	2029-00	6,04	393, 395
141013-750		376	146021-413	130,93	420	2030-00	6,30	395
141030-701	5,28	377, 398	146023-412	100,59	420	2031-00	5,07	393
141031-000	76,20	376	146023-422	113,21	421	2032-00	5,00	267
141031-710		376	146023-623	152,82	421	2033-00	11,55	267
141031-750		376	146041-313	104,39	420	2034-00	5,72	267
141032-000	51,24	376	146043-312	84,59	420	2040-00	84,36	388
141032-710		376	146043-322	140,16	421	2040-200	82,54	388
141032-750		376	146200-700	3,18	431	2040-80	3,61	394
141033-000	59,22	376	146200-701	3,57	431	2044-00	17,44	316, 390
141033-710		376	146200-702	4,22	431	2045-00	26,47	390
141033-750		376	146200-710	0,100	431	2045-09	27,02	316
141050-701	3,55	377, 398	146223-412	100,83	423	2046-00	47,67	390
141051-000	60,87	376	146223-422	116,08	425	2046-055	42,97	322
141051-710		376	146223-623	139,92	426	2046-09	58,58	318
141051-750		376	146223-624	133,92	428	2046-1200	57,61	392
141052-000	51,98	376	146223-800	181,49	428	2047-055	52,23	323
141052-710		376	146223-824	129,93	427	2047-09	52,75	319
141052-750		376	146224-301	79,23	422	2047-1200	41,55	392
141053-000	44,50	376	146224-321	99,67	425	2048-1200	69,56	392
141053-710		376	146224-322	99,27	425	2049-00	75,86	314
141053-750		376	146224-622	113,18	426	2049-055	91,63	320
142001-000	105,37	397	146225-411	77,79	422	2049-80	4,15	314, 318, 320, 322
142001-710		397	146225-421	81,26	424	2050-00	82,19	388
142002-000	91,80	397	146225-822	127,30	426	2050-200	98,55	388
142002-710		397	146243-312	89,00	423	2050-60	82,77	389
142011-000	92,15	397	146243-322	101,16	425	2050-80	4,40	394
142011-710		397	146243-600	161,84	428	2050-82	2,88	394
142012-000	78,27	397	146243-624	97,36	427	2050-83	2,90	394
142012-710		397	146245-311	62,06	422	2054-00	30,70	316, 390
142031-000	56,13	396	146245-321	66,59	424	2055-00	44,52	390
142031-710		396	146245-622	105,36	426	2055-09	45,07	317
142032-000	69,03	396	146273-212	73,14	423	2056-00	52,35	390
142032-710		396	146273-222	69,78	425	2056-055	57,33	322
142051-000	62,65	396	146273-323	83,98	426	2056-09	55,50	318
142051-710		396	146273-324	88,79	428	2056-092	51,03	325
142052-000	44,58	396	146273-424	101,23	426	2056-1200	52,35	392
142052-710		396	146274-322	70,82	426	2057-055	60,89	323
143001-000	98,51	409	146275-211	43,68	422	2057-09	59,42	319
143001-716		409	146275-221	46,70	424	2057-092	60,43	325
143001-80	4,18	412	146275-422	71,77	426	2057-1200	68,43	392
143001-811	2,96	412	148436-00L	121,14	470	2058-1200	70,14	392
143002-000	84,45	409	148436-00R	122,38	470	2059-00	79,53	314
143002-80	0,030	412	148436-130		470	2059-002	86,50	324
143002-811	2,72	412	148436-701	0,260	471	2059-055	100,27	320
143003-000	61,94	409	148436-704	2,96	471	2059-80	4,97	314, 318, 320, 322
143003-80	2,77	412	148436-708	0,300	471	2059-802	5,47	324
143003-811	2,41	412	148436-709	0,300	471	2060-00	99,52	388
143003-88	3,09	412	148436-710		470	2066-055	51,02	322
143011-000	79,56	411	148466-00L	95,02	470	2066-09	74,59	318
143011-716		411	148466-00R	94,96	470	2067-055	62,04	323
143012-000	48,53	411	148466-710		470			
143013-000	69,82	411		2...				
143031-000	66,14	411	2016-000	9,94	317, 390			
143031-716		411	2016-110	5,74	370			

Order no.	Weight	Page
2067-09	75,56	319
2069-00	99,56	314
2069-055	115,37	320
2069-80	5,97	314, 318, 320, 322
2140-00	108,79	389
2140-100	97,54	389
2140-80	2,28	394
2144-00	36,97	317, 391
2145-00	51,69	391
2145-09	51,96	317
2146-00	65,80	391
2146-055	64,58	322
2146-09	63,50	318
2146-1200	85,87	392
2147-055	73,34	323
2147-09	93,29	319
2147-1200	84,66	392
2148-1200	100,83	392
2149-00	105,75	315
2149-055	113,89	321
2149-80	2,40	315, 318, 321, 322
2150-00	116,84	389
2150-100	109,77	389
2150-60	110,81	389
2150-80	3,38	394
2150-82	2,35	394
2150-83	2,27	394
2154-00	39,82	317, 391
2155-00	62,34	391
2155-09	61,56	317
2156-00	75,40	391
2156-055	71,53	322
2156-09	70,45	318
2156-092	72,94	325
2156-1200	75,35	392
2157-055	77,40	323
2157-09	85,23	319
2157-092	90,21	325
2157-1200	97,58	392
2158-1200	106,75	392
2159-00	108,12	315
2159-002	118,07	324
2159-055	121,07	321
2159-80	2,97	315, 318, 321, 322
2159-802	4,22	324
2160-00	126,71	389
2166-055	79,30	322
2166-09	85,33	318
2167-055	86,57	323
2167-09	89,71	319
2169-00	125,66	315
2169-055	135,77	321
2169-80	3,55	315, 318, 321, 322
3...		
3200-00L	51,20	402
3200-00R	59,40	402
3200-088L		402
3200-701	1,05	407
3200-7021		407
3200-7027		407
3200-80	1,98	407
3200-82	1,61	407
3200-83	1,62	407

Order no.	Weight	Page
3200-88	2,31	407
3201-00	69,61	402
3201-80	2,62	407
3201-811	7,57	407
3201-82	1,84	407
3201-83	1,86	407
3201-88	2,95	407
3202-00	65,36	402
3202-80	3,22	407
3202-811	8,18	407
3202-82	2,13	407
3202-83	2,15	407
3203-00	72,95	402
3203-80	3,94	407
3203-811	9,11	407
3203-82	2,42	407
3203-83	2,45	407
3211-00	60,40	405
3212-00	62,54	405
3212-0800	6,92	404
3212-1000	9,45	404
3212-1200	11,34	404
3213-00	69,05	405
3221-00	49,86	404
3222-00	55,71	404
3223-00	70,81	404
3231-00	44,53	405
3232-00	50,43	405
3233-00	49,83	405
3241-00	42,60	404
3242-00	45,29	404
3243-00	51,48	404
3251-00	34,26	406
3252-00	41,91	406
3253-00	37,67	406
3260-00L	17,55	406
3260-00R	17,37	406
3261-00	20,79	406
3262-00	21,87	406
3263-00	27,84	406
4...		
4221-25	0,530	373, 394
4222-25	1,20	373, 394
4400-7002	0,200	183
4400-7006	0,200	183
4500-10	4,15	184
4500-11	4,15	184
4500-700		173, 175, 177, 179, 183
4500-705	1,66	184
4500-707	0,450	184
4500-715	0,040	97, 157, 184
4500-760	0,100	184
4500-765	1,41	184
4500-766	1,78	184
4500-7703R	0,110	185
4500-770R	0,110	185
4500-7713R	0,110	185
4500-771R	0,110	185
4500-7733	0,110	185
4500-773R	0,110	185
4500-775	0,120	185
4500-776	0,120	185
4500-777	0,120	185
4500-778	0,120	185
4501-010	36,90	328
4501-020	70,91	328

Order no.	Weight	Page
4501-140	55,90	328
4502-010	47,55	328
4502-020	81,66	328
4502-070	21,24	329
4502-100	82,87	329
4502-130	162,80	329
4502-140	66,55	328
4503-010	59,40	328
4503-020	93,51	328
4503-070	133,09	329
4503-100	99,07	329
4503-130	174,65	329
4503-140	78,40	328
45100-10	32,35	172
45100-12	35,78	172
45100-20	54,85	172, 183
45100-22	60,42	172, 183
45100-30	75,14	173
45100-32	85,36	173
45100-40	98,20	173
45101-10	34,21	174
45101-12	40,64	174
45101-20	58,56	174
45101-22	69,16	174
45101-30	80,71	175
45101-32	90,38	175
45101-40	105,64	175
45102-10	38,66	176
45102-12	40,53	176
45102-20	66,44	176
45102-22	66,38	176
45102-30	92,52	177
45102-32	95,77	177
45102-40	121,39	177
45103-10	39,34	176
45103-12	42,61	176
45103-20	66,83	176
45103-22	73,12	176
45103-30	93,12	177
45103-32	104,16	177
45103-40	122,19	177
45104-10	41,48	178
45104-12	46,96	178
45104-20	70,10	178
45104-22	79,86	178
45104-30	97,58	179
45104-32	112,77	179
45104-40	122,29	179
45105-10	44,85	178
45105-12	47,60	178
45105-20	71,88	178
45105-22	83,13	178
45105-30	98,39	179
45105-32	111,68	179
45105-40	127,69	179
45107-20		183
45107-22		183
45110-710		172
45110-730		172
45112-710		172
45112-730		172
45120-710		172
45120-730		172
45122-710		172
45122-730		172
45130-710		173
45130-730		173

# Order number and weight register

Order no.	Weight	Page	Order no.	Weight	Page	Order no.	Weight	Page
45132-710		173	4800-7871	0,400	252	54780-150		474
45132-730		173	48010-1210	49,41	251	5722-00	24,35	393
45140-710		173	48010-2210	82,68	251	5722-80	2,57	393
45140-730		173	480103-10	21,66	202	5723-00	39,80	393
45180-122	56,57	180	480103-20	28,46	202	5723-80	0,010	393
45180-132	52,73	180	480103-30	38,48	202	5724-00	45,62	393
45180-224	102,98	180	480103-40	46,83	202	5724-80	2,57	393
45180-234	92,79	180	48020-1204EB	39,13	252	5725-00	32,79	393
45180-326	145,76	181	48020-1210	52,69	251	5725-80	0,010	393
45180-336	132,51	181	48020-220404EB	68,94	252	57700-701	2,26	405, 407
45180-438	177,13	181	48020-2210	103,44	251	<b>6...</b>		
45181-326	140,16	180	480203-10	20,00	202	6103-10		418, 437
45181-336	118,51	180	480203-20	38,37	202	6103-11		418, 430, 437
45210-710		174	480203-30	39,47	202	6103-12		418, 430, 437
45210-730		174	480203-40	60,48	202	6103-13	0,010	418, 430, 437
45212-710		174	48060-105	41,45	250	6400-01		417, 423
45212-730		174	48060-110	51,37	250	6400-401		420
45220-710		174	48060-205	67,60	250	6400-402		420
45220-730		174	48060-210	87,59	250	6400-410		422, 424, 426
45222-710		174	48070-210	45,26	250	6400-411		422, 424, 426
45222-730		174	48160-105	43,61	250	6400-412		422, 424, 426
45230-710		175	48160-110	53,53	250	64011-000		431
45230-730		175	48160-205	69,66	250	64020-00	3,27	418
45232-710		175	48160-210	89,65	250	6492-00	1,03	431
45232-730		175	48170-210	52,39	250	6493-10	1,96	431
45240-710		175	48270-7015	0,500	250	6494-10	0,740	418, 431
45240-730		175	483103-10	21,44	203	6494-20	0,740	431
4531-70	4,64	183	483103-20	29,52	203	6495-10	0,310	418, 431
4532-70	3,94	183	483103-30	40,05	203	6496-10	0,180	431
4533-70	5,17	183	483103-40	52,67	203	6700-01		417, 421, 423
4534-70	6,39	183	483203-10	21,10	203	6700-410		426
4541-70	3,50	183	483203-20	37,21	203	6700-412		422, 425, 426
45410-710		176	483203-30	41,73	203	67011-000		431
45410-730		176	483203-40	61,29	203	67020-00	3,59	418
45412-710		176	4901-0601	0,050	201, 213	6900-01		417, 421, 423
45412-730		176	4901-0611	0,030	201, 213	6900-401		420, 421
4542-70	7,98	183	4902-0601		201, 213	6900-402		420, 421
45420-710		176	4902-0611		201, 213	6900-410		423, 425, 426, 428
45420-730		176	<b>5...</b>			6900-411		423, 425, 427, 428
45422-710		176	51022-1.1	35,59	452	6900-412		423, 425, 426, 427, 428
45422-730		176	51022-1.9	8,67	452	69011-000		431
4543-70	6,39	183	51022-2.10	8,58	452	69020-00	4,27	418
45430-710		177	5400-760		474	<b>7...</b>		
45430-730		177	540490-1.1	62,04	446	7000-10	0,010	436
45432-710		177	540490-1.10	64,44	446	7000-20	0,010	436
45432-730		177	540490-1.8	69,78	446	7000-80		436
45440-710		177	540700-707L	0,500	446	7100-000	96,39	435
45440-730		177	540700-707M	0,500	446	7100-100	74,67	435
45610-710		178	540700-707R	0,500	446	7100-5051	3,10	437
45610-730		178	540700-7084	2,00	447	7100-704	0,110	437
45612-710		178	540700-7085	2,00	447	7100-705	0,160	437
45612-730		178	540700-7086	3,00	447	7100-706	0,280	437
45620-710		178	540700-713	0,250	447	7100-709	3,01	437
45620-730		178	540700-715	0,370	447	7101-000	171,71	435
45622-710		178	540700-717	0,330	447	7101-100	112,49	435
45622-730		178	540700-721L	0,250	446	7101-200	148,00	435
45630-710		179	540700-721M	0,250	446	7103-000	7,15	436
45630-730		179	540700-721R	0,250	446	7104-000	16,46	436
45632-710		179	540700-722L	0,250	446	7105-000	17,49	436
45632-730		179	540700-722M	0,250	446	7106-000	6,00	436
45640-710		179	540700-722R	0,250	446	7200-000	125,62	435
45640-730		179	540708-1.1		446	7200-100	94,85	435
46112-21181	143,95	191	540708-1.10		446	7200-706	0,450	437
46113-2118	144,95	191	540708-1.8		446			
46121-730		191	5413-780		474			
4800-1210		251	54780-000		474			
4800-2210		251	54780-010		474			

Order no.	Weight	Page
7201-000	221,93	435
7201-100	144,99	435
7201-200	191,15	435
7203-000	8,86	436
7204-000	22,14	436
7205-000	26,90	436
7206-000	7,00	436
781120-40	76,02	350
781120-60	98,49	350
781120-80	98,15	350
781125-40	79,04	350
781125-60	101,51	350
781125-80	101,17	350
781130-40	82,05	350
781130-60	104,52	350
781130-80	104,52	350
781140-80	15,87	350
781160-80	21,49	350
781180-80	16,48	350
781220-40	85,99	350
781220-60	111,65	350
781220-80	137,30	350
781225-40	89,01	350
781225-60	114,67	350
781225-80	140,32	350
781230-40	92,02	350
781230-60	117,68	350
781230-80	143,33	350
781240-80	18,37	350
781260-80	24,78	350
781280-80	31,19	350
781320-40	102,58	350
781320-60	133,56	350
781320-80	164,52	350
781325-40	105,59	350
781325-60	136,57	350
781325-80	167,54	350
781330-40	108,60	350
781330-60	139,58	350
781330-80	170,55	350
781340-80	22,51	350
781360-80	30,26	350
781380-80	38,00	350
7820-40	29,77	348
7820-41	21,75	348
7820-42	29,44	348
7820-43	21,54	348
7820-50	32,84	348
7820-51	24,44	348
7820-52	32,45	348
7820-53	24,18	348
7820-60	35,91	349
7820-61	27,13	349
7820-62	35,47	349
7820-63	26,83	349
7825-40	35,07	349
7825-41	24,50	349
7825-42	34,46	349
7825-43	24,05	349
7825-50	38,51	349
7825-51	27,38	349
7825-52	37,84	349
7825-53	26,87	349
7825-60	41,96	349
7825-61	30,26	349
7825-62	41,23	349
7825-63	29,71	349

Order no.	Weight	Page
7830-704	0,050	343, 345, 347, 349
7830-705	0,050	343, 345, 347, 349
7830-706	0,050	343, 345, 347, 349
7830-707	0,050	343, 345, 347, 349
7840-80	3,43	349
7842-80	3,41	348
7850-80	4,01	349
7852-80	3,98	348
7860-80	4,59	349
7862-80	4,55	348
78820-40	27,56	344
78820-41	21,25	344
78820-42	26,78	344
78820-43	20,53	344
78820-50	31,22	344
78820-51	24,53	344
78820-52	30,31	344
78820-53	23,68	344
78820-60	34,87	345
78820-61	27,81	345
78820-62	33,83	345
78820-63	26,83	345
78825-40	34,80	345
78825-41	26,36	345
78825-42	33,85	345
78825-43	25,49	345
78825-50	39,41	345
78825-51	30,41	345
78825-52	38,30	345
78825-53	29,38	345
78825-60	44,02	345
78825-61	34,46	345
78825-62	42,75	345
78825-63	33,28	345
78840-80	2,98	345
78842-80	2,83	344
78850-80	3,43	345
78852-80	3,38	344
78860-80	3,99	345
78862-80	3,93	344
<b>8...</b>		
8000-001	0,100	201, 240
8000-01	0,050	201, 240
8000-061	0,130	238
8000-063	0,400	238
8000-25		238
8000-7021		225
8000-7035		225
8000-718	0,120	201
8000-9010		225
8050-000	10,67	224
8050-010	13,42	224
8050-100	13,76	226
8050-110	27,19	226
8050-200	37,74	227
8050-210	45,99	227
8050-7100	4,22	225
8051-000	16,74	224
8051-010	16,60	224
8051-100	26,03	226
8051-110	30,24	226
8051-200	43,52	227
8051-210	47,89	227

Order no.	Weight	Page
8051-7100	4,22	225
8052-000	15,40	224
8052-010	23,83	224
8052-100	37,43	226
8052-110	44,10	226
8052-200	63,94	227
8052-210	75,46	227
8052-7100	8,43	225
8060-000	12,76	228
8060-010	15,50	228
8060-100	13,23	230
8060-110	29,86	230
8060-200	19,26	230
8060-210	24,64	230
8060-300	26,05	228
8060-310	28,39	228
8060-400	44,20	229
8060-410	45,93	229
8060-7100	2,69	231
8061-000	20,01	228
8061-010	21,95	228
8061-100	41,59	230
8061-110	42,29	230
8061-200	26,84	230
8061-210	76,57	230
8061-300	36,11	228
8061-310	38,84	228
8061-400	64,32	229
8061-410	68,76	229
8061-7100	3,92	231
8062-000	24,70	228
8062-010	29,17	228
8062-100	47,17	230
8062-110	51,71	230
8062-200	83,42	230
8062-210	90,59	230
8062-300	46,55	228
8062-310	49,24	228
8062-400	74,07	229
8062-410	82,61	229
8062-7100	2,70	231
8070-01	13,41	238
8070-02	9,50	238
8070-3720	94,63	210
8070-3721	97,29	210
8070-3722	94,30	210
8070-3723	97,56	210
8070-3730	112,96	210
8070-3731	126,66	210
8070-3732	115,57	210
8070-3733	119,40	210
80700-00	49,98	236
80700-10	27,63	239
80700-20	49,80	239
80700-201	41,35	254
80700-203	35,39	254
80700-221	26,76	254
80700-223	23,18	254
80700-231	19,46	254
80700-233	17,08	254
80700-30	72,09	239
80700-40	96,58	239
8071-01	19,22	238
8071-02	16,28	238
8071-03	53,82	237
80710-00	74,24	236
80720-00	74,99	237



# Order number and weight register

Order no.	Weight	Page	Order no.	Weight	Page	Order no.	Weight	Page
8073-01	19,12	238	8501-04	0,010	184	8820-000	41,32	275
8073-02	16,28	238	8501-04251	0,400	184	8821-000	44,73	275
80730-00	91,96	237	8501-0551		201, 213, 240	8821-052	41,51	289
80730-20	140,12	237	8501-06	0,020	201, 213	8821-055	42,82	285
8074-00	9,03	238	8504-172	4,27	212	8821-0552	44,89	294
8077-30	0,100	201, 240	8504-173	4,96	212	8821-315	46,68	301
8077-300	0,100	240	8504-201	4,86	195	8821-316	46,32	301
8078-2101	1,30	225	8504-272	5,00	212	8821-5035	72,80	282
8078-2111	1,77	225	8504-273	7,92	212	8821-5235	90,73	290
8078-4101	0,410	231	8504-301	5,18	195	8821-713	4,75	277
8078-4111	3,44	231	8504-372	6,38	212	88210-00	51,03	276
8170-111	39,89	255	8504-373	7,94	212	88210-80	4,78	276
8170-201	54,28	194	8504-401	8,40	195	8830-000	54,22	275
8170-211	73,34	255	8505-02	0,080	203	8830-5035	80,95	282
8170-301	80,13	194	8520-000	43,84	275	8831-000	51,65	275
8170-311	119,88	255	8521-000	49,00	275	8831-052	58,25	289
8170-401	100,28	194	8521-052	48,96	289	8831-055	56,22	285
8270-172	36,86	210	8521-055	50,96	285	8831-0552	56,22	294
8270-173	52,43	210	8521-0552	54,62	294	8831-5035	81,00	282
8270-201	51,84	194	8530-000	61,17	275	8831-5235	107,03	290
8270-202	76,59	196	8531-000	61,67	275	88500-00	1,75	277
8270-203	80,09	196	8531-052	72,31	289	8851-00	1,50	301
8270-272	64,52	210	8531-055	62,14	285	8900-00	41,60	266
8270-273	80,66	210	8531-0552	68,39	294	8900-02	38,42	268
8270-301	86,55	194	8550-000	9,63	222	8900-052	47,63	288
8270-302	94,40	196	8551-000	13,23	222	8900-055	44,17	284
8270-303	112,77	196	8552-000	16,80	222	8900-7131		273, 283, 373
8270-372	97,42	211	8570-172	39,42	208	8900-721	0,050	273, 283, 373
8270-373	114,08	211	8570-173	63,91	208	8900-7211	0,050	273, 275, 283, 368, 373
8270-401	100,11	194	8570-201	86,93	194			
82700-00	64,15	236	8570-202	89,76	197			
82700-10	38,19	239	8570-203	83,18	197	8900-723	0,080	273, 283, 373
82700-20	68,41	239	8570-272	70,39	208	8900-740	0,070	265
8271-272	44,02	206	8570-273	102,39	208	8900-750	0,070	265
8271-273	58,47	206	8570-301	11,88	194	8900-80	2,49	266, 268, 284
8271-372	65,25	206	8570-302	131,30	197			
8271-373	81,50	206	8570-303	124,83	197	8900-802	3,64	288
82710-00	95,46	236	8570-372	101,84	209	8901-00	45,45	266
8370-201	68,37	194	8570-373	107,06	209	8901-02	47,21	268
8370-202	70,41	197	8570-401	113,13	194	8901-052	52,05	288
8370-203	83,70	197	8570-70	0,100	213	8901-055	65,84	284
8370-301	106,36	194	8570-710	0,100	213	8901-315	52,25	300
8370-302	97,41	197	8570-711		213	8901-316	49,73	300
8370-303	107,69	197	8573-201	49,34	200	8901-3725	3,37	300
8370-401	103,06	194	8573-272	54,60	207	8901-3726	4,23	300
8370A202	60,94	198	8573-273	64,58	207	8901-80	2,49	266, 268, 284
8370A302	81,12	198	8573-301	72,26	200			
8470-172	41,67	208	8573-372	76,92	207	8901-802	4,49	288
8470-173	52,14	208	8573-373	97,81	207	8910-00	49,51	266
8470-201	62,98	194	8573-7201		200	8910-02	42,21	268
8470-202	70,65	196	8573-7272		212	8910-055	48,28	284
8470-203	74,79	196	8573-7273		212	8910-80	2,53	266, 268, 284
8470-272	85,44	208	8573-7301		200			
8470-273	85,52	208	8573-7372		212	8911-00	56,73	266
8470-301	93,12	194	8573-7373		212	8911-02	44,41	268
8470-302	97,48	196	8670-201	65,24	194	8911-055	62,96	284
8470-303	111,71	196	8670-301	96,37	194	8911-80	2,97	266, 268, 284
8470-372	100,73	209	8670-401	126,79	194			
8470-373	122,67	209	8721-315	33,80	301	8920-00	57,57	266
8470-401	117,55	194	8721-316	29,64	301	8920-02	55,14	268
8470A202	56,27	198	8721-7010	0,880	276, 277	8920-052	71,88	288
8470A302	85,61	198	8721-713	2,38	276, 277	8920-055	67,67	284
8472-272	49,75	207	8721-71656	6,80	276, 277	8920-0552	66,75	292
8472-273	58,88	207	8721-80	2,40	276	8920-312		279
8472-372	69,28	207	87210-00	30,35	276	8920-313	65,36	278
8472-373	80,97	207	8750-00	0,780	276, 277	8920-314	68,05	278
8500-718	0,060	213	8751-00	1,00	301	8920-3707	1,44	279

Order no.	Weight	Page
8920-59101	0,240	304
8920-59105	0,010	304
8920-59153	35,40	304
8920-59155	35,40	304
8920-59201	0,460	304
8920-59204	0,010	304
8920-59205	0,010	304
8920-59253	4,80	304
8920-59255	4,80	304
8920-59301	0,960	304
8920-59304	0,050	304
8920-59305		304
8920-59353	6,20	304
8920-59355	6,20	304
8920-59401	2,04	304
8920-59402	0,010	304
8920-59404	0,060	304
8920-59405	0,020	304
8920-59453	5,90	304
8920-59455	5,90	304
8920-59501	2,04	304
8920-59502	0,010	304
8920-59504	0,020	304
8920-59505	0,030	304
8920-59553	7,90	304
8920-59555	7,90	304
8920-59601	4,36	304
8920-59604	0,030	304
8920-59605	0,030	304
8920-59606	0,600	304
8920-59653	9,20	304
8920-59655	9,20	304
8920-59701	6,42	304
8920-59702	0,020	304
8920-59704	0,030	304
8920-59705	0,030	304
8920-59706	0,600	304
8920-59753	8,88	304
8920-59755	8,88	304
8920-80	2,92	266, 268, 278, 284
8920-802	3,42	288
8921-00	67,40	267
8921-02	61,47	269
8921-052	68,11	288
8921-055	74,58	285
8921-0552	76,58	292
8921-055E1	78,23	298
8921-055E3	91,91	298
8921-05E1	74,11	298
8921-05E3	83,74	298
8921-301	139,04	272
8921-302	187,59	273
8921-303	184,08	273
8921-3041	100,15	270
8921-3042	103,84	270
8921-305	116,67	271
8921-306	121,19	272
8921-311	72,16	278
8921-312		279
8921-313	73,67	278
8921-314		279
8921-315	72,65	300
8921-316	72,77	300
8921-3707	1,86	270, 272, 278, 279
8921-3713	1,10	271, 272

Order no.	Weight	Page
8921-3716	2,28	271, 272
8921-3722	18,00	270, 272
8921-3723	13,54	270, 272
8921-3725	5,41	300
8921-3726	7,27	300
8921-503	135,74	280
8921-5030	95,70	281
8921-523	110,80	290
8921-5230	106,27	291
8921-553	99,67	286
8921-5530	130,48	287
8921-55302	114,55	292
8921-5532	119,08	293
8921-5702	31,97	299
8921-5713	2,80	283, 291, 295
8921-5718	5,22	283, 291, 295
8921-700	0,080	271, 273
8921-701	1,00	283, 290, 295
8921-703	1,00	299
8921-80	4,07	267, 269, 278, 279, 280, 281, 285, 287, 298
8921-802	4,57	288, 291
8921-80E1	7,89	299
8922-00	75,19	267
8922-02	65,32	269
8922-052	75,90	289
8922-055	82,37	285
8922-0552	83,55	292
8922-503	133,65	280
8922-5030	138,46	281
8922-523	163,76	290
8922-5230	114,64	291
8922-553	111,64	286
8922-5530	106,83	287
8922-55302	122,11	292
8922-5532	127,42	293
8922-80	4,83	267, 269, 280, 281, 285, 287
8922-802	5,33	289, 291
8924-00	81,85	267
8924-02	73,23	269
8924-052	100,31	289
8924-055	94,33	285
8924-0552	95,62	292
8924-80	4,83	267, 269, 285
8924-802	5,33	289
8930-00	71,78	267
8930-02	54,80	269
8930-052	72,32	289
8930-055	82,65	285
8930-0552	84,65	293
8930-314		279
8930-503	88,04	280
8930-5030	82,06	281
8930-5713	2,50	283, 295
8930-5718	6,14	283, 295
8930-701	0,130	283, 295
8930-80	4,23	267, 269, 279, 280, 281, 285
8930-802	4,73	289
8931-00	81,86	267

Order no.	Weight	Page
8931-02	65,06	269
8931-052	93,90	289
8931-055	92,73	285
8931-0552	94,72	293
8931-301	163,42	273
8931-302	142,21	273
8931-303	230,41	273
8931-3041	123,66	271
8931-3042	112,40	270
8931-305	140,51	271
8931-306	124,10	272
8931-311	79,45	278
8931-314		279
8931-3707	2,36	270, 272, 278
8931-3713	1,60	271, 272
8931-3716	2,85	271, 272
8931-3722	20,87	270, 272
8931-3723	15,24	270, 272
8931-501	144,10	311
8931-502	122,95	311
8931-503	113,66	280
8931-5030	113,06	281
8931-523	142,77	290
8931-5230	125,54	291
8931-553	135,01	286
8931-5530	119,28	287
8931-55302	137,69	292
8931-5532	143,42	293
8931-5713	2,80	283, 291, 295, 310
8931-5718	7,09	283, 291, 295
8931-700	0,080	271, 273
8931-701	1,00	283, 290, 295
8931-80	5,27	267, 269, 279, 280, 281, 285, 287
8931-802	5,77	289, 291
8932-00	89,31	267
8932-02	72,51	269
8932-052	103,17	289
8932-055	100,18	285
8932-0552	102,18	293
8932-503	128,61	280
8932-5030	116,31	281
8932-523	196,71	290
8932-5230	133,42	291
8932-553	133,31	286
8932-5530	127,17	287
8932-55302	145,58	292
8932-5532	152,22	293
8932-80	6,18	267, 269, 280, 281, 285, 287
8932-802	6,68	289, 291
8934-00	110,69	267
8934-02	88,63	269
8934-052	118,84	289
8934-055	121,34	285
8934-0552	125,56	293
8934-80	8,32	267, 269, 285
8934-802	9,32	289
9...		
9134-000	39,95	362
9135-000	50,13	362
9136-000	37,11	362

# Order number and weight register

Order no.	Weight	Page	Order no.	Weight	Page	Order no.	Weight	Page
9137-000	57,35	362	9495-009	42,09	274	99001-0652-012		445
9160-000	37,61	363	99001-0001-183		448	99001-3104-K02		462
9160-410	65,15	367	99001-0002-183		448	99001-3104-N02		462
9160-600	45,91	367	99001-0003-183		448	99001-3105-K01		463
9164-000	13,51	368	99001-0004-183		448	99001-3105-N01		463
9165-000	25,86	369	99001-0005-183		448	99001-3108-K03		462
9166-1200	27,65	370	99001-0006-183		448	99001-3108-N03		462
9167-1200	36,27	371	99001-0007-183		448	99001-3121-K05		463
9180-000	54,32	363	99001-0008-183		448	99001-3121-N05		463
9184-000	16,38	368	99001-0009-183		448	99001-3122-K04		463
9185-000	23,91	369	99001-0010-183		449	99001-3122-N04		463
9186-1200	35,16	370	99001-0011-183		449	99001-3505-N01		465
9187-1200	43,71	371	99001-0012-183		449	99001-3505-N02		465
9190-000	62,70	363	99001-0013-183		449	99001-3505-N03		465
9234-000	37,98	360	99001-0014-183		449	99001-3505-N04		465
9235-000	43,80	360	99001-0015-183		449	99001-3505-N05		465
9236-000	49,42	360	99001-0016-183		449	99002-000001	3,11	346
9237-000	57,20	360	99001-0017-183		449	99002-000002	3,62	346
9260-000	57,48	361	99001-0018-183		449	99002-000003	4,12	346
9260-100	74,02	364	99001-0019-183		450	99002-000010	23,55	342
9260-30	60,59	365, 372	99001-0020-183		450	99002-000011	40,92	342
9260-410	74,14	366	99001-0021-183		450	99002-000012	29,91	342
9260-600	59,93	366	99001-0022-183		450	99002-000013	49,30	342
9264-000	17,43	274	99001-0023-183		451	99002-000014	23,42	342
9265-000	26,39	369	99001-0024-183		451	99002-000015	40,82	342
9265-009	26,36	274	99001-0025-183		442	99002-000016	30,30	342
9266-1200	37,86	370	99001-0026-183		442	99002-000017	50,11	342
9267-1200	45,88	371	99001-0027-183		442	99002-000018	2,32	343
9280-000	64,87	361	99001-0030-001		460	99002-000019	2,21	343
9280-088	62,19	279, 365	99001-0030-002		460	99002-000020	3,87	343
9280-100	71,95	364	99001-0031-803		466	99002-000021	3,69	343
9280-30	67,21	365, 372	99001-0032-240		464	99002-000022	3,26	347
9284-000	20,30	274	99001-0033-240		464	99002-000023	3,79	347
9285-000	30,30	369	99001-0034-057		466	99002-000024	4,33	347
9285-009	30,88	274	99001-0034-820		466	99002-000031	22,62	346
9286-1200	43,46	370	99001-0035-240		466	99002-000032	21,78	346
9287-1200	47,05	371	99001-0036-240		466	99002-000033	25,66	346
9290-000	72,38	361	99001-0037-000		468	99002-000034	24,69	346
9294-000	27,52	274	99001-0037-240		468	99002-000035	28,70	347
9295-000	35,72	369	99001-0038-001		468	99002-000036	27,60	347
9295-009	36,37	274	99001-0038-260		468	99002-000043	28,01	347
9360-000	63,37	363	99001-0039-000		468	99002-000044	26,99	347
9360-80	4,24	361, 363, 369	99001-0039-001		468	99002-000045	31,76	347
9360-811	8,59	372	99001-0040-010		456	99002-000046	30,60	347
9364-000	16,74	368	99001-0040-014		456	99002-000047	35,53	347
9365-000	33,48	369	99001-0040-016		456	99002-000048	34,20	347
9366-1200	38,25	370	99001-0041-023		458	99002-000055	28,94	346
9367-1200	45,67	371	99001-0041-025		458	99002-000056	28,02	346
9380-000	69,90	363	99001-0041-026		458	99002-000057	32,35	346
9384-000	20,10	368	99001-0042-023		458	99002-000058	31,31	346
9385-000	29,83	369	99001-0042-025		458	99002-000059	35,76	347
9386-1200	45,99	370	99001-0042-026		458	99002-000060	34,59	347
9460-000	84,40	361	99001-0043-086		454	99002-000067	36,45	347
9464-000	22,05	274	99001-0044-086		454	99002-000068	35,34	347
9465-000	33,71	369	99001-0045-086		454	99002-000069	40,76	347
9465-009	33,69	274	99001-0046-086		454	99002-000070	39,51	347
9466-1200	46,63	370	99001-0047-086		454	99002-000071	45,08	347
9467-1200	56,45	371	99001-0048-086		454	99002-000072	43,67	347
9480-000	81,50	361	99001-0049-086		454	99003-0001	0,800	328
9484-000	25,41	274	99001-0050-086		454	99003-0002	1,18	328
9485-000	38,53	369	99001-0051-086		454	99003-0003	0,750	328
9485-009	38,58	274	99001-0141-042		444	99003-0004	1,33	328
9486-1200	54,09	370	99001-0241-042		444	99003-0005	2,17	328
9487-1200	64,44	371	99001-0341-042		444	99003-0006	2,99	328
9490-000	89,19	361	99001-0421-021		445	99003-0007	0,800	330
9494-000	30,49	274	99001-0452-012		445	99003-0008	1,39	330
9495-000	42,19	369	99001-0552-012		445	99003-0009	2,27	330

Order no.	Weight	Page
99003-0010	3,14	330
99003-0011	9,93	329
99003-0012	15,78	329
99003-0013	21,62	329
99003-0014	16,08	329
99003-0015	21,92	329
99003-0016	2,02	329
99003-0017	2,70	329
99003-0018-002	126,00	330
99003-0019-002	133,19	330
99003-0020-002	97,00	330
99003-0021-002	81,60	330
99003-0022	0,760	330
99003-0023	1,02	330
99003-0024	1,39	330
99003-0025	2,65	330
99003-0026	4,60	330
99003-0027-002	115,60	330
99003-0028-002	168,67	330
99003-0029-002	219,36	330
99003-0030-002	210,90	330
99003-0031-002	185,03	332
99003-0032-002	171,91	332
99003-0033-002	189,68	332
99003-0034-002	227,74	332
99003-0035	1,06	332
99003-0036	1,40	332
99003-0037	3,66	332
99003-0038	2,97	332
99003-0039	4,93	332
99003-0040	7,15	332
99003-0041	2,66	332
99003-0042	4,45	332
99003-0043	6,71	332
99003-0044-002	74,87	333
99003-0045-002	80,44	333
99003-0046-002	84,76	333
99003-0047	4,18	333
99003-0048	7,76	333
99003-0049	3,70	333
99003-0050	16,68	333
99003-0051	12,86	333
99003-0052-002	103,60	334
99003-0053-002	108,93	334
99003-0054-002	113,91	334
99003-0055	6,31	334
99003-0056	11,77	334
99003-0057	4,60	334
99003-0058	21,44	334
99003-0059	15,45	334
99003-0060-002	138,03	334
99003-0061-002	131,28	334
99003-0062-002	146,37	334
99003-0063	7,57	335
99003-0064	14,05	335
99003-0065	6,39	335
99003-0066	26,20	335
99003-0067	20,75	335
99003-0068	1,05	336
99003-0069	1,56	336
99003-0070	0,920	336
99003-0071	2,49	336
99003-0072	4,16	336
99003-0073	6,01	336
99003-0074	1,72	336
99003-0075	3,37	336
99003-0076	7,19	336

Order no.	Weight	Page
99003-0077	10,49	336
99003-0078	0,720	336
99003-0079	1,57	336
99003-0080	2,15	336
99003-0081	1,84	336
99003-0082	4,09	336
99003-0083	6,76	336
99003-0084	9,89	336
99003-0085	4,63	336
99003-0086	7,67	336
99003-0087	11,18	336
99003-0088	1,08	336
99003-0089-002	49,50	337
99003-0090-002	65,41	337
99003-0094	0,030	338
99003-0095	0,030	338
99003-0096	0,040	338
99003-0097	0,060	338
99003-0098	0,030	338
99003-0099	0,040	338
99003-0100	0,040	338
99003-0101	0,090	338
99003-0102	0,470	338
99003-0103	0,060	338
99003-0104	0,070	338
99003-0105	0,100	338
99003-0106	0,020	339
99003-0107	0,020	339
99003-0108	0,020	339
99003-0109	0,020	339
99003-0110	0,020	339
99003-0111	0,040	339
99003-0112	0,040	339
99003-0113	0,040	339
99003-0114	0,040	339
99003-0115	0,040	339
99003-0116	0,060	338
99003-0117	0,050	338
99003-0118	0,060	338
99003-0119	0,070	338
99003-0120	0,140	339
99003-0121	0,170	339
99003-0122	0,140	339
99003-0123	0,280	339
99003-0124	0,180	339
99003-0125	0,350	339
99003-0126	0,070	339
99003-0127	0,120	339
99003-0128	0,170	339
99003-0129	0,010	338
99003-0130	0,040	338
99003-0131	0,300	339
99003-0132	1,13	339
99003-0133	1,69	339
99003-0134	2,01	339
99003-0135	0,030	338
99003-0136	0,040	338
99003-0137	0,050	338
99003-0138	0,030	338
99003-0139	0,060	338
99003-0140	0,070	338
99003-0141	0,070	338
99003-0142	0,110	338
99003-0143	0,040	339
99003-0144	0,060	339
99003-0145	0,060	339
99003-0146	0,040	339

Order no.	Weight	Page
99003-0147	0,050	339
99003-0148	0,590	339
99003-0149	0,890	339
99003-0150	2,01	338
99003-0151	4,05	338
99003-0152	6,11	338
99003-0153	8,17	338
99003-0154	0,040	331
99003-0155	0,060	331
99004-000001		235
99004-000002		235
99004-000003		235
99004-000004		235
99004-000005		235
99004-000012		234
99004-000039		234
99004-000060		234
99004-000061		234
99004-000062		234
99004-000063		234
99004-000064		234
9964-00	4,01	266, 361, 363, 371
99699-00001	27,00	452
99699-00002	33,00	452
99699-00003	37,00	452
9984-00	4,35	267, 363, 371
9994-00	4,35	267, 363



# Index

## A

A brief portrait of C+P	8–9
Acoustic tambour, Asisto	408–411
Acurado cabinet systems	360–373, 388–395, 416–419
Acurado drawer and filing cabinets	416–419
Acurado hinged-door cabinets	360–373
Acurado sliding-door cabinets	388–395
Asisto desks	446–447
Asisto drawer and filing cabinets	420–431
Asisto fridge caddy	474–475
Asisto hinged-door cabinets	374–382
Asisto occasional tables	448–449
Asisto pull-out cabinets	470–471
Asisto sit/stand tables	446–447
Asisto sliding-door cabinets	396–399
Asisto tambour cabinets	408–413
Assembled box lockers	80–85, 134–143, 176–179, 192–205, 206–213
Assembled box lockers with acrylic glass doors	198–199

## B

Bar stools	468–469
Basic benches and benches with coat rack	224–227
Basic benches with coat rack	224–227
Battery charging cabinets	298–299
Benches and benches with coat rack	220–231
Benches, stackable	222–223
Benches with coat rack for wet rooms	228–231
Binder supports	373, 381, 394, 398, 407, 412
Boltless file shelving	342–343
Boltless long shelving units	350
Boltless shelving	340–351

## C

C+P added value	4–7
C+P cleaner	23
Cabinets with hinged doors (office)	356–385
Cabinets with hinged doors (workshop)	262–279, 280–295, 296–311
Cabinets with tambour doors	400–413
Cabinets with tambour doors (Asisto)	408–413
Cabinets with tambour doors (Omnispace)	402–407
Caddy with trash can	474–475
Cafeteria tables	452–453
Cambio lockers	166–185
Card-index cabinets	416–431
Certos hinged-door cabinets, flame-resistant	382–385
Chairs	460–469
Changing room rails	225, 231, 234
Changing room systems	232–241
Changing room systems and assembled box lockers	236–241
Classic PLUS accessories	94–97
Classic PLUS lockers	60–97
Classic PLUS top lockers (changing room)	86–87
Cleaning equipment lockers	74, 124
Cleaning supply lockers	74, 124
Climate Office plant and water walls	42–43
Coat hangers for changing room systems	155, 184, 234, 238
Color concept	44–49

Combination lock	161, 163, 217
Comfort benches and benches with coat rack (HPL)	228–231
Comfort benches with coat rack (HPL)	228–231
Compartmentalized loading lockers	252–253
Computer cabinets	337
Conference chairs	464–467
Conference solutions	450–453
Conference tables	450–453
Contents	3
Corrosion protection and quality assurance	22
Counters	440–441

## D

Decor concept	50–53
Decor tables	51, 53
Delivery conditions	20–21
Desks, Asisto	446–447
Dirty/clean separation lockers	64–65, 70–73, 114–123
Dispensing lockers for laundry	250
Double-tier lockers	76–79, 126–133, 174–175, 195–196, 203, 205, 210–211
Drawer cabinets (office/archive)	414–437
Drawer cabinets (workshop)	333–336
Drawing cabinets for horizontal storage	432–437
Drying and ventilation (lockers)	170–171, 190–191
Drying lockers, Flex PLUS	190–191

## E

Electronic locking systems	162–163, 214–218, 265, 359
Ergo-Lock grip lock	264–265, 358–359
EURO-LOCKS PIN code lock	162–163, 216
EvoLo PLUS accessories	154–157
EvoLo PLUS lockers	98–157
Exhaust air ventilation system for lockers	170–171
Extra-large assembled box lockers	196–197, 210–211
Extra-large assembled box lockers with acrylic glass doors	198–199
Extra-large tool cabinets	267

## F

Filing cabinets	416–423, 416–431
Fire service lockers	244–249
Flame-resistant cabinets	382–385
Flex PLUS drying lockers	190–191
Floor lamps	456–457
Folding tables	450–453
Free-standing wardrobes	235
Fridge caddy, Asisto	474–475

## G

Gantner, electronic locking systems	214–215
Green walls	42–43

## H

Hangers for changing room systems	95
Hanging cabinet/Hanging shelf	274
Hazardous substance cabinets	300–301
Hedge elements	42–43
Hinged-door cabinets, flame-resistant	382–385

Hinged-door cabinets for heavy loads	288–295
Hinged-door cabinets (office)	356–385
Hinged-door cabinets with viewing window doors	284–287, 292–295
Hook assortments	338–339
Horizontal storage cabinets	432–437

## I

Intro assembled box lockers	194–201
-----------------------------	---------

## K

Kindergarten lockers	202–203
----------------------	---------

## L

Labels for multi-drawer cabinets	437
Lamps	456–457
Laptop lockers	251
Laundry bags	250
Laundry collection locker	250
Laundry dispensing locker	250
Laundry lockers	74, 124
Laundry storage lockers	74–75, 124–125, 250
Loading assembled box lockers	252–253
Loading cabinets	298–299
Loading lockers	252–253
Lockers	60–97, 98–157, 166–185, 186–191
Lockers, double-tier	76–79, 126–133, 174–175, 195–196, 203, 205, 210–211
Lockers, EvoLo PLUS	98–157
Lockers for dirty/clean separation	64–65, 70–73, 114–123
Lockers for schools and kindergartens	202–205
Lockers for street and work clothing	64–65, 70–73, 114–123
Lockers for wet rooms	94, 154, 160
Lockers, Prefino	186–191
Lockers, slim	256–257
Lockers, space-saving	256–257
Lockers with compartment width of 250 mm	256–257
Locking systems for lockers and assembled box lockers	158–165, 216–219
Locks for changing room and assembled box lockers	158–165, 216–219
Logistics	16–21
Logistics services	20–21
Long shelving units	350
Lounge furniture	442–445

## M

Master key systems	160
Mechanical combination lock	161, 163, 217
Meeting tables	450–453
Mobile conference tables	450–451
Mobile folding tables	450–451
Mobile pedestals, Asisto	472–473
Monitor arms	458–459
Monitor holders	458–459
Mounting elements for perforated plate systems	338–339
Multi-drawer cabinets	432–437
Multi-purpose lockers	74–75, 124–125

**O**

Occasional bookcases	370–371
Occasional cabinets for desks	393, 406
Occasional cabinets for heavy loads	289, 325
Occasional cabinets for workbenches	275–277
Occasional cabinets with viewing window doors	285, 294, 322–323
Occasional sliding-door cabinets	392–393
Occasional tables	448–449
Occasional tambour cabinets	406
Office bookcases	342–343, 362–363, 367, 378–379
Office coat stands	234–235
Open changing room systems	236–241
Open-front container cabinets	302–311
Open-front containers, loose	304
Order number and weight register	482–495

**P**

Partition systems	40–41
pCon planning support	11
Perforated plate systems	338–339
Pharmacists cabinets	470–471
PIN code locks	162–163, 216–218, 265, 359
Planning support, pCon	11
Prefino lockers	186–191
Privacy elements for desks	454–455

**Q**

Quality assurance and corrosion protection	22
--	----

**R**

Reception counters	440–441
Reference examples	24–35
Resisto assembled box lockers	206–213
RFID locks	162–163, 218, 265, 359

**S**

Safe deposit box lockers	255
SAFE-O-MAT locks	164–165, 219
SAFE-O-TRONIC locks	162, 218
School and kindergarten lockers	202–205, 206–213
Shelving for binders	342–343, 362–363
Shelving for warehouse/archive/workshop	268–269, 340–351, 362–363
Single perforated plates	338–339
Sit/stand workstations, Asisto	446–447
Sliding-door cabinets	315–316, 321–322, 324–325
Sliding-door cabinets (office)	386–399
Sliding-door cabinets (warehouse/workshop)	312–325
Sliding-door cabinets with viewing window doors	320–323
Slim lockers	256–257
Sloping top for lockers	94, 154, 183, 212
Small-compartment lockers	254–255
Smart locker	34–35, 38–39
Sofas	444–445
Space-saving lockers	88–89, 146–153, 180–181, 256–257
Stackable benches	222–223
Stackable chairs	466–467
Standing tables	442–443, 448–449

Storage cabinets	279, 365
Storage lockers for laundry	74–75, 124–125, 250
Storage shelving	340–351
Street and work clothing lockers	64–65, 70–73, 114–123
Suspension bars (Elba/Leitz or Zippel system)	373, 384, 394, 407
Swivel chairs	460–463

**T**

Tabletop lectern for tool cabinets	277
Tambour cabinets, Asisto	408–413
Tambour cabinets, Omnispace	402–407
Task chairs	464–467
Tool cabinets for heavy loads	288–295, 324–325
Tool cabinets with drawers and security compartments	270–273
Tool cabinets with hinged doors	263–279, 280–295, 296–311
Tool cabinets with hinged doors and drawers	280–283, 286–287, 290–291, 293
Tool cabinets with hinged doors and viewing window	284–287, 292–295
Tool cabinets with open-front containers	302–311
Tool cabinets with sliding doors	312–325
Tool cabinets with viewing window sliding doors	320–323
Tool top cabinets	274
Top bookcases (office)	368–369
Top cabinets for tools	274, 316–317
Top cabinets (office)	368–369, 390–391, 406
Top cabinets with sliding doors (office)	390–391
Top decors	51, 53
Top lockers, Evolo PLUS (changing room)	144–145
Transponder locks	162–163, 217–218, 265, 359
Trapezoidal tables	452
Trend products	36–43

**U**

Umbrella stands	235
Underframes	266–267, 360–363, 371, 393, 395, 418, 431, 436
Universal cabinets (office)	360–361
Universal cabinets (warehouse/workshop)	266–267

**V**

Ventilation according to the SVL concept	170–171
Ventilation and drying (lockers)	170–171, 190–191
Viewing window cabinets	284–287, 292–295, 298–299, 320–323
Visitor chairs	464–465

**W**

Wall-mounted wardrobes	234
Wardrobe systems	234–241
Water walls	42–43
Weight register	482–495
Wet room benches with coat rack	228–231
Workbenches	328–332
Workbenches with cabinet	330–332
Workbench occasional cabinets	275–277

Workshop shelving units	268–269, 344–351
Workstation dividers	454–455

**Z**

Z lockers	88–93, 146–153, 180–181
-----------	-------------------------

4-foot tables	452
78-series boltless shelving (for moderately heavy loads)	346–347
78-series shelving (for moderately heavy loads)	346–347
788-series boltless shelving (for standard loads)	344–345
788-series shelving (for standard loads)	344–345
7800-series boltless shelving (for heavy loads)	348–349
7800-series shelving (for heavy loads)	348–349

# Don't miss any news

## Subscribe to our newsletter.



### Always up to date

Subscribe to our newsletter and always be up to date! Our newsletter enables you to receive informative and interesting content directly in your inbox on a regular basis. Be the first to learn about new products, exclusive offers and exciting events.

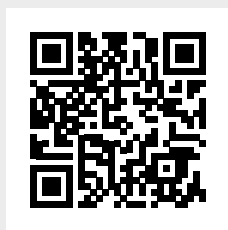

**Subscribe to the newsletter now:**  
It's about more than just our steel lockers. We promise.  
Discover more furniture solutions.

### Why should you subscribe to our newsletter? A few of the benefits you'll be able to enjoy:

- + **Current information:** You'll receive regular updates on new products, services and offers.
- + **Events and workshops:** When we organize special events or workshops, we inform our newsletter subscribers about them first.
- + **Multiple languages:** We offer our newsletter in multiple languages so each reader is able to understand and enjoy the content in their preferred language.
- + **Flexibility:** We respect your privacy and never pass your e-mail address on to third parties. You also have the option to unsubscribe from the newsletter at any time should you no longer wish to receive the information.

# Be a part of our digital community

## Follow us on social media.

Always be just one click away from the latest information and exciting offers. Follow us on our social media channels and stay connected to us around the clock. Gain inspiration from our posts, images and videos and discover exclusive insights behind the scenes. Become a part of our growing online family and never miss news again in the future.

C + P Möbelsysteme GmbH & Co. KG  
cp\_derstahlschrank

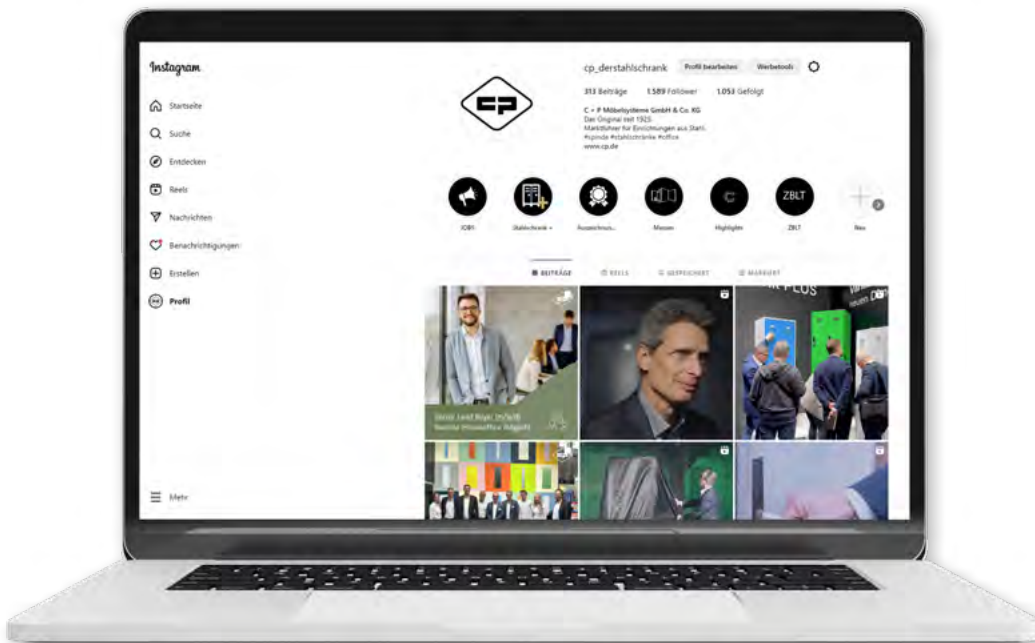

## General information

This publication is for informational purposes. It does not constitute a quotation as defined by law and is only intended for business customers. All items are supplied without any decorations shown in the illustrations. The trademark and product rights of any branded products which may appear in the decorations are reserved by the respective manufacturer. The specified dimensions are only approximate and may be larger or smaller. We reserve the right to make structural changes, changes to the assortment & availability and changes to the color, material & decor ranges, as well as to limit express availability if necessary (e.g. in case of larger quantities of a model or order).

All previous catalogs and price lists become invalid as of the publication of this catalog. All pricing information represents non-binding price recommendations from the manufacturer, does not include the value added tax applicable on the day of delivery and is intended for commercial customers. We reserve the right to make changes to pricing information, e.g. due to errors or increases in the price of raw materials or other materials.

Our General Terms and Conditions of Business apply (see [www.cp.de/agb](http://www.cp.de/agb)).

Issued: August 2023 - 1688742607 - Valid from October, 2023 until the publication of a new issue.  
Publisher/Copyright: C + P Möbelsysteme GmbH & Co. KG - [www.cp.de](http://www.cp.de)



**C + P Möbelsysteme GmbH & Co. KG**

Boxbachstr. 1  
35236 Breidenbach | Germany

T +49 6465 919-340  
sales@cp.de  
www.cp.de

**Follow us on social media:**

C + P Möbelsysteme GmbH & Co. KG  
cp\_derstahlschrank



Valid from October 1, 2023